

REVISIONS				
P	LTN	DESCRIPTION	DATE	APPV
A		NEW DRAWING	03APR2019	RS JO

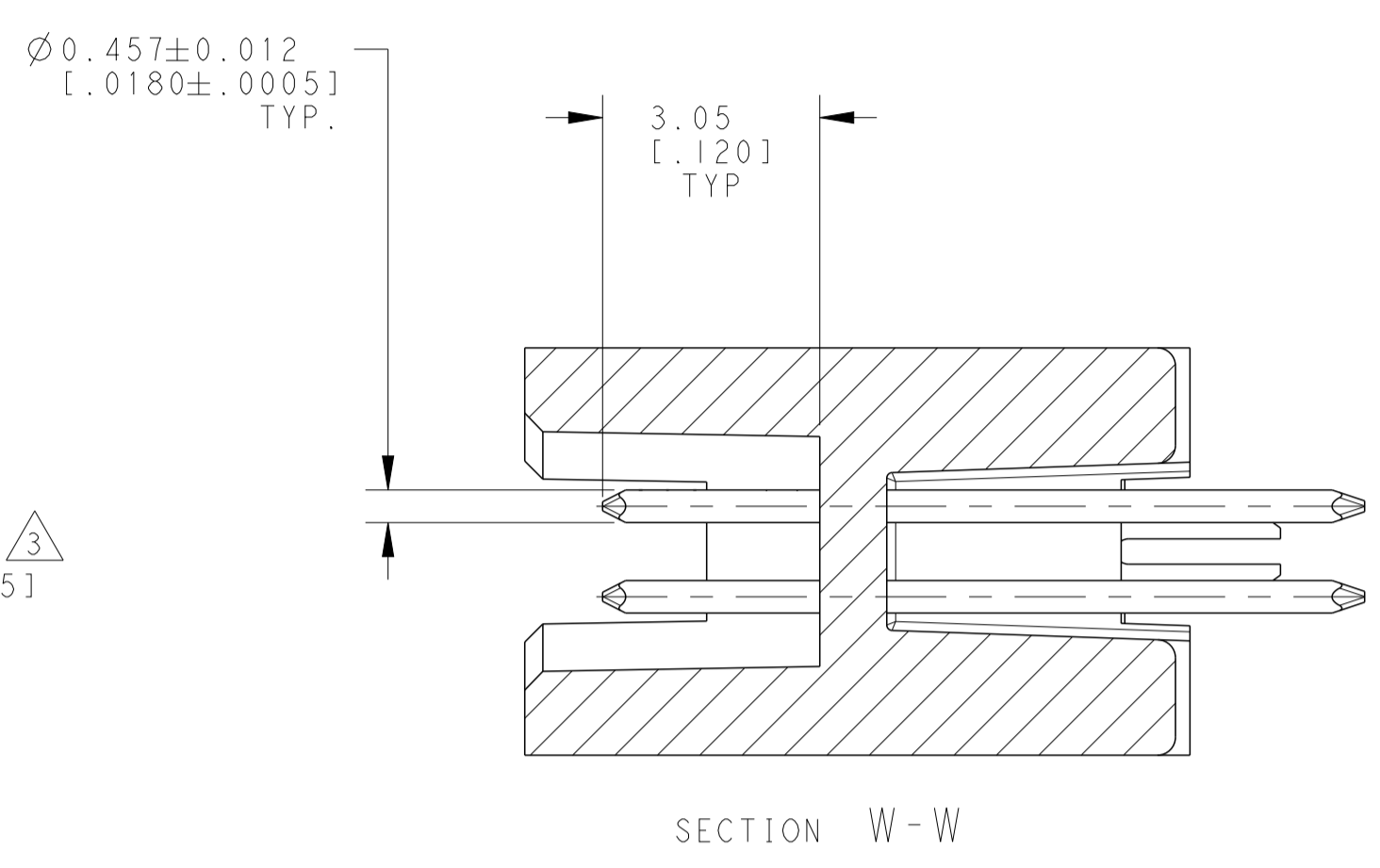

- 1 0.00076 [0.00030] GOLD AT POINT OF MEASUREMENT, 0.00051 [0.00020] MIN AT THE END OF AREA G, (LOCALIZED GOLD PLATE AREA), 0.0038 [0.00150] TIN-LEAD ON LOCALIZED TIN PLATED AREA, ALL OVER 0.0013 [0.00050] NICKEL
- 2 USE 1.32 ± 0.02 [0.0520 ± 0.0010] DRILLED HOLE (#55 DRILL). FINISH TO BE TIN OVER 0.02 [0.001] MIN COPPER.
- 3 DIMENSION APPLIES AT BASE OF SHROUD.
- 4 THE NOTED DIMENSIONS APPLY AT THE MATING FACE OF THE HOUSING.
- 5 0.0038 [0.00150] TIN LEAD ON HOLD DOWN, ALL OVER 0.0013 [0.00050] NICKEL.
- 6 IF PLANNING TO USE MORE THAN ONE MATING PAIR OF CONNECTORS TO INTERCONNECT 2 BOARDS, PLEASE REFER TO THE SPACING PARAGRAPH IN APPLICATION SPEC, #114-7010
- 7 PACKAGED IN TUBES
- 8 DIMENSIONS NOTED APPLY FROM THE BASIC DIMENSION LINE (NOT THE CIRCUIT CAVITY CENTER LINE) TO THE SURFACE INDICATED.
- 9 0.00076 [0.00030] GOLD AT POINT OF MEASUREMENT, 0.00051 [0.00020] MIN AT THE END POINTS OF AREA G, (LOCALIZED GOLD PLATE AREA), 0.0038 [0.00150] TIN ON LOCALIZED TIN PLATED AREA, ALL OVER 0.0013 [0.00050] NICKEL.
- 10 USE 1.32 ± 0.02 [0.0520 ± 0.0010] DRILLED HOLE (#55 DRILL) FINISH TO BE TIN OVER 0.02 [0.001] MIN COPPER.
- 11 0.0038 [0.00150] TIN ON HOLDDOWN, ALL OVER 0.0013 [0.00050] NICKEL
- 12 ROHS 2002/95/EC COMPLIANT
- 13 HOUSING: LCP, COLOR: BLACK
POST: PHOSPHOR BRONZE
VACUUM COVER: ALUMINIUM
HOLD DOWN: COPPER ALLOY

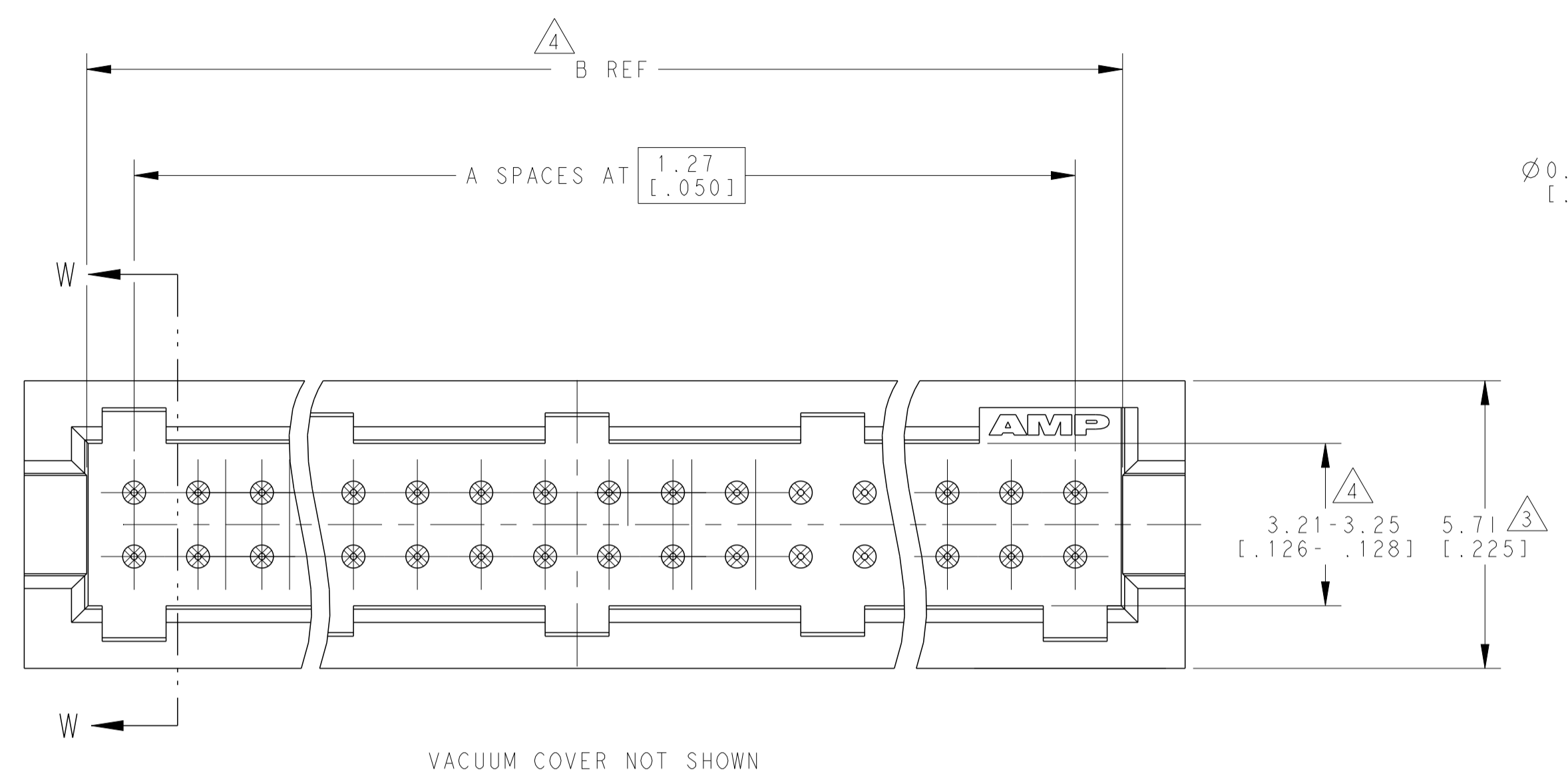
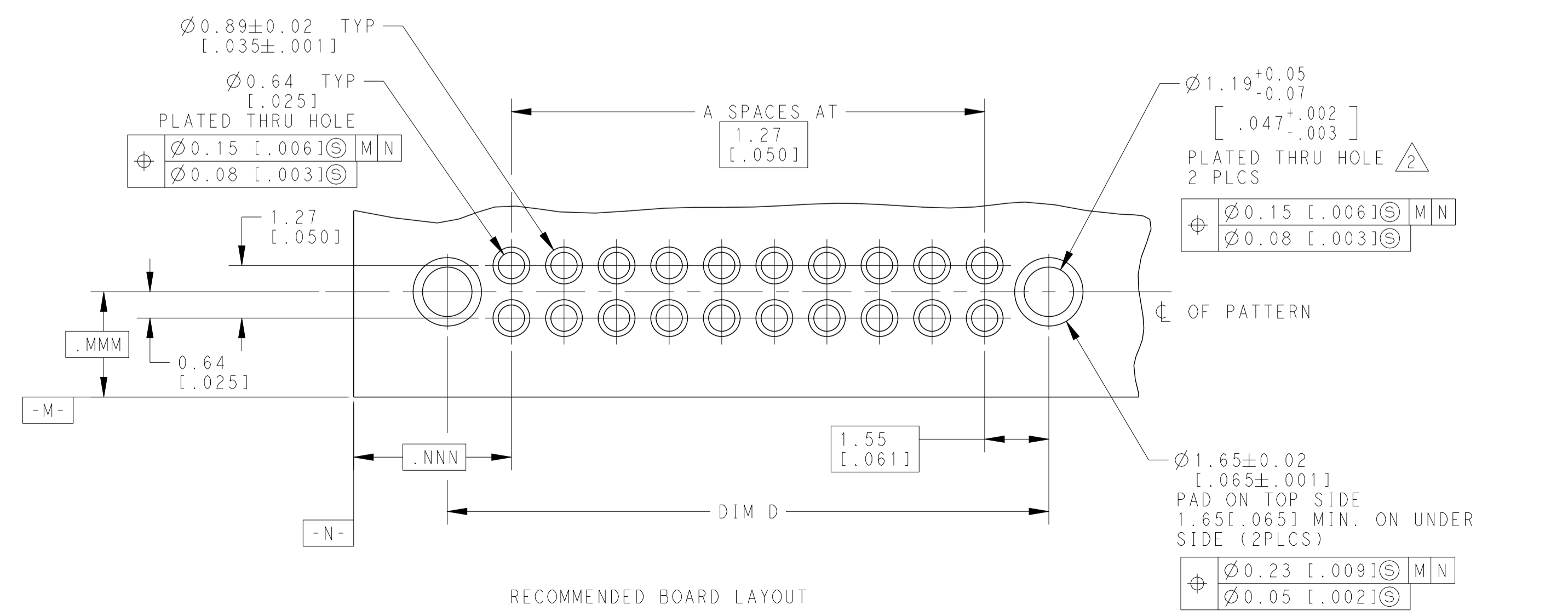
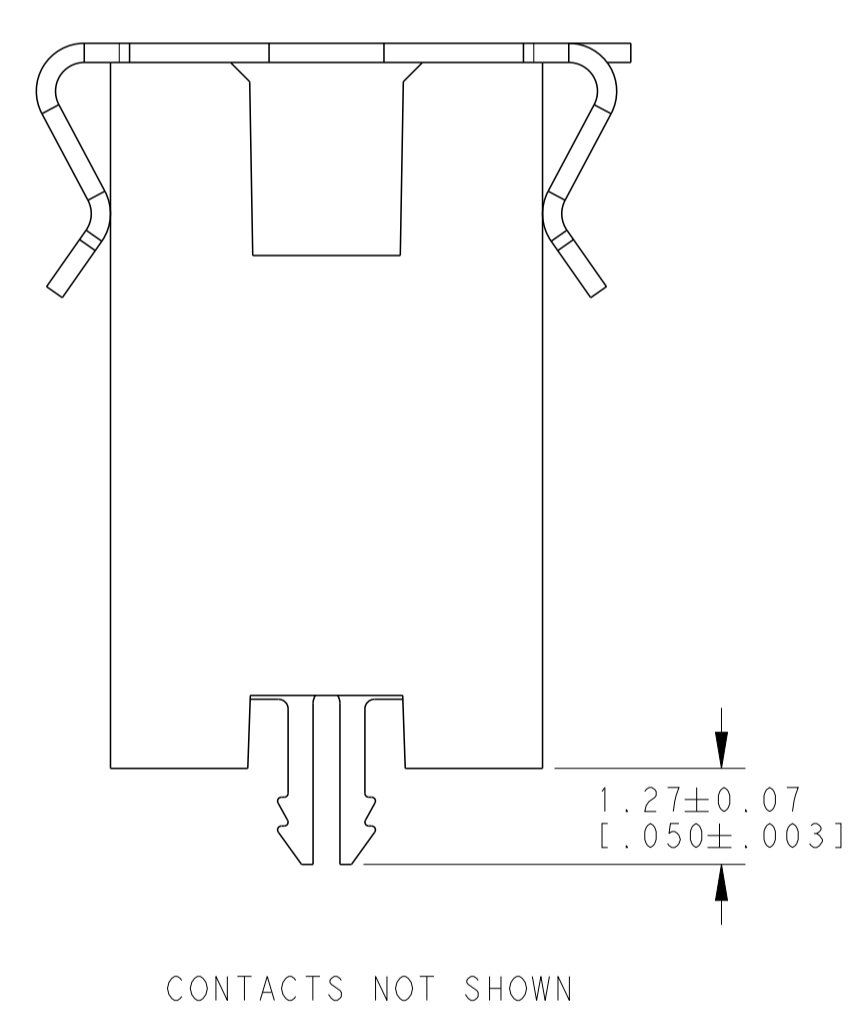
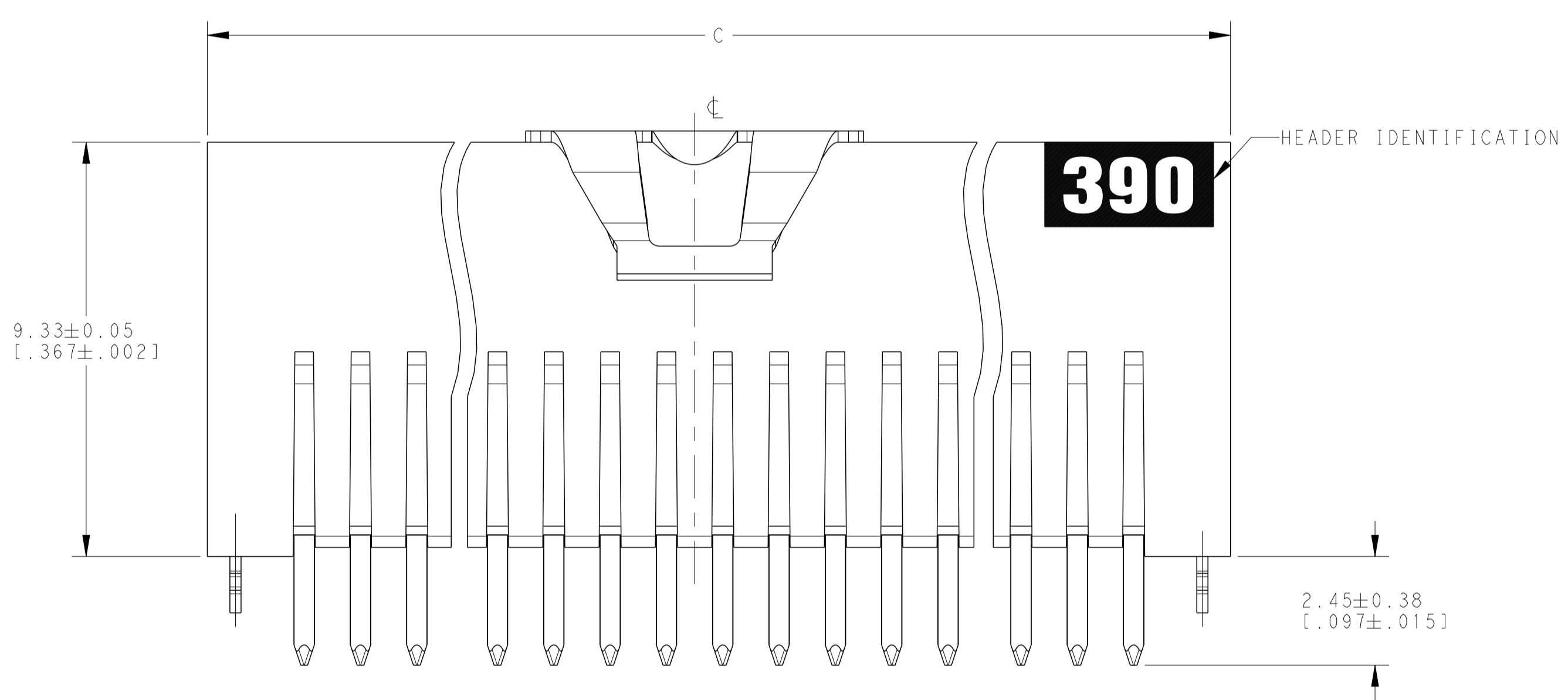

FINISH	D	C	B	A	NUMBER OF POSITIONS	PART NUMBER
9 1	65.33 [2.572]	66.59 [2.622]	64.05 [2.522]	49	100	6-2267256-0
9 1	58.98 [2.322]	60.24 [2.372]	57.70 [2.272]	44	90	5-2267256-9
9 1	52.63 [2.072]	53.89 [2.122]	51.35 [2.022]	39	80	5-2267256-8
9 1	46.28 [1.822]	47.54 [1.872]	45.00 [1.772]	34	70	5-2267256-7
9 1	39.93 [1.572]	41.19 [1.622]	38.65 [1.522]	29	60	5-2267256-6
9 1	33.58 [1.322]	34.84 [1.372]	32.30 [1.272]	24	50	5-2267256-5
9 1	27.23 [1.072]	28.49 [1.122]	25.95 [1.022]	19	40	5-2267256-4
9 1	20.88 [0.822]	22.14 [0.872]	19.60 [0.772]	14	30	5-2267256-3
9 1	14.53 [0.572]	15.79 [0.622]	13.25 [0.522]	9	20	5-2267256-2
9 1	8.18 [0.322]	9.44 [0.372]	6.90 [0.272]	4	10	5-2267256-1
1 5	65.33 [2.572]	66.59 [2.622]	64.05 [2.522]	49	100	1-2267256-0
1 5	58.98 [2.322]	60.24 [2.372]	57.70 [2.272]	44	90	2267256-9
1 5	52.63 [2.072]	53.89 [2.122]	51.35 [2.022]	39	80	2267256-8
1 5	46.28 [1.822]	47.54 [1.872]	45.00 [1.772]	34	70	2267256-7
1 5	39.93 [1.572]	41.19 [1.622]	38.65 [1.522]	29	60	2267256-6
1 5	33.58 [1.322]	34.84 [1.372]	32.30 [1.272]	24	50	2267256-5
1 5	27.23 [1.072]	28.49 [1.122]	25.95 [1.022]	19	40	2267256-4
1 5	20.88 [0.822]	22.14 [0.872]	19.60 [0.772]	14	30	2267256-3
1 5	14.53 [0.572]	15.79 [0.622]	13.25 [0.522]	9	20	2267256-2
1 5	8.18 [0.322]	9.44 [0.372]	6.90 [0.272]	4	10	2267256-1

THIS DRAWING IS A CONTROLLED DOCUMENT. DWG: RAVLS 03APR2019
CHK: J. OLSON 03APR2019
APPV: J. OLSON 03APR2019

DIMENSIONS: mm [INCH] TOLERANCES UNLESS OTHERWISE SPECIFIED: 0 PLC ±, 1 PLC ±, 2 PLC ±, 3 PLC ±, 4 PLC ±, ANGLES ±.

MATERIAL: FINISH: SEE TABLE

NAME: HDR ASSY, THROUGH HOLE AMPMODU 50/50 GRID (9.90 [0.390] MATED HEIGHT)

SIZE: 108-1332 APPLICATION SPEC 114-7010

WEIGHT: A100779 C=2267256

CUSTOMER DRAWING SCALE: 10:1 SHEET 1 OF 1 REV A