

REVISIONS

P	LTR	DESCRIPTION	DATE	DWN	APVD
A		NEW DRAWING	23FEB2017	CHS	VVB
C		AS PER ECR-17-006143	29AUG2017	CHS	VVB
C1		AS PER ECR-19-009305	13JUN2019	CHS	VVB
D		AS PER ECR-20-000074	29JAN2020	MS	DH

NOTES:

- ⑩ ▲ TE CONNECTIVITY PART NUMBER
- ⑪ ▲ TE CONNECTIVITY TRADEMARK
- ⑫ ▲ PART REVISION INDEX - SEE TABLE
- ⑬ ▲ MATERIAL MARKING
- ⑭ ▲ MOLD CAVITY IDENTIFICATION NUMBER
- ⑮ ▲ PRODUCTION DATE
- ⑯ ▲ MATERIAL IDENTIFIER
- 8. MATED WITH CAP HOUSING PART NUMBER 2307645-1
- 9. THIS PART MUST BE USED WITH DOUBLE LOCK PLATE P/N - 2307647-1
- 10. FOR DETAILS OF APPLICABLE TERMINALS, SINGLE WIRE SEAL AND WIRE TYPE - SEE PRODUCT SPEC. : 108-94594 OR EJ MK II SEALED CONNECTOR CATALOGUE
- 11. FOR CRIMP DETAILS- SEE APPLICATION SPEC. 114-94473
- 12. BULK PACKAGING IN CORUGATED BOX
- ⑰ ▲ ⑳ ▲ CONTACT CAVITY IDENTIFICATION.

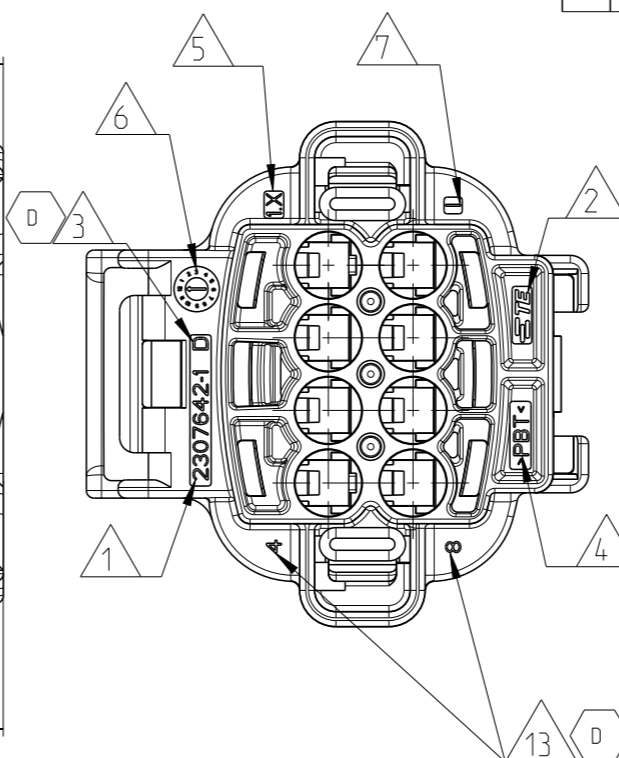
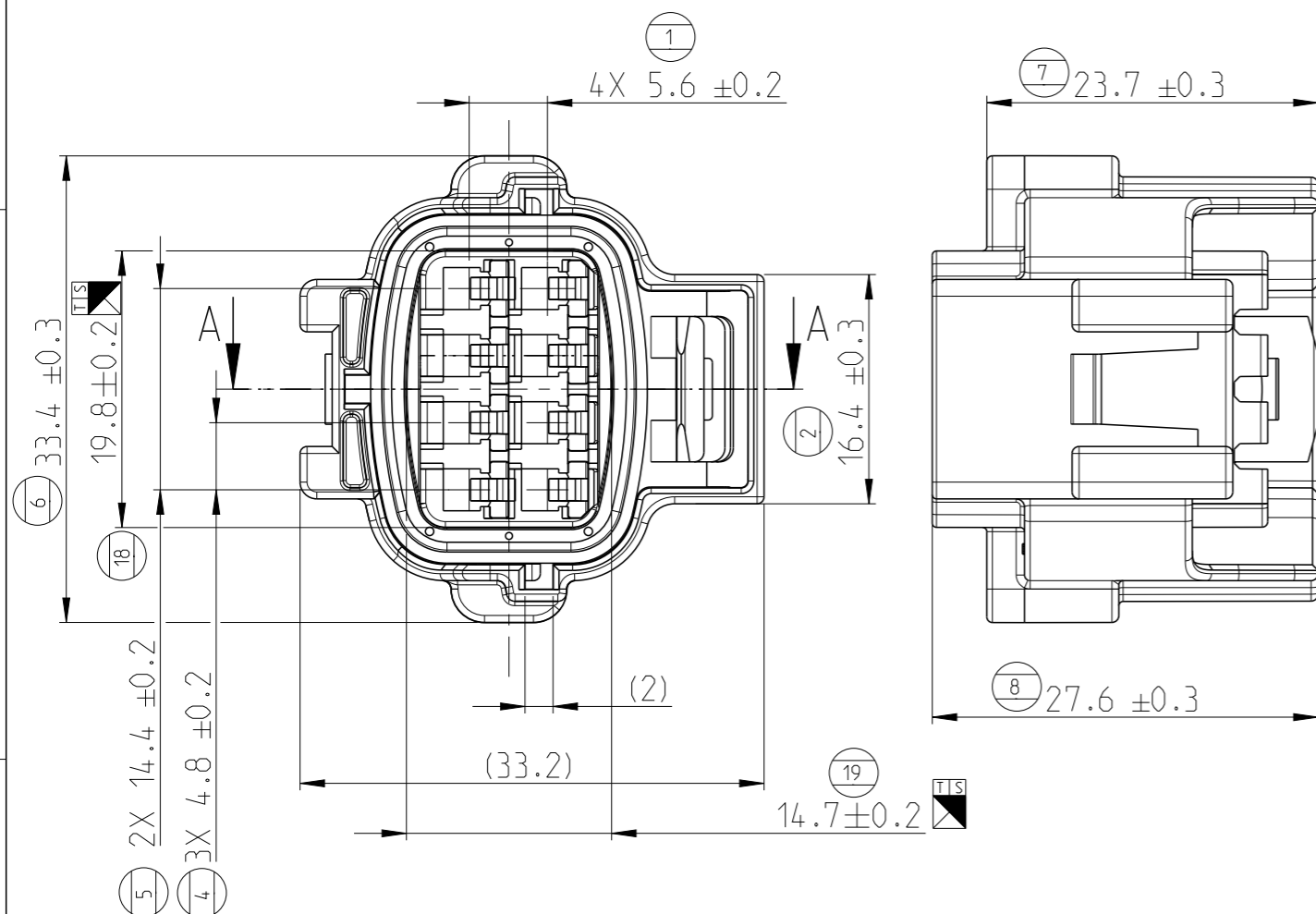

SECTION A-A

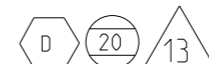
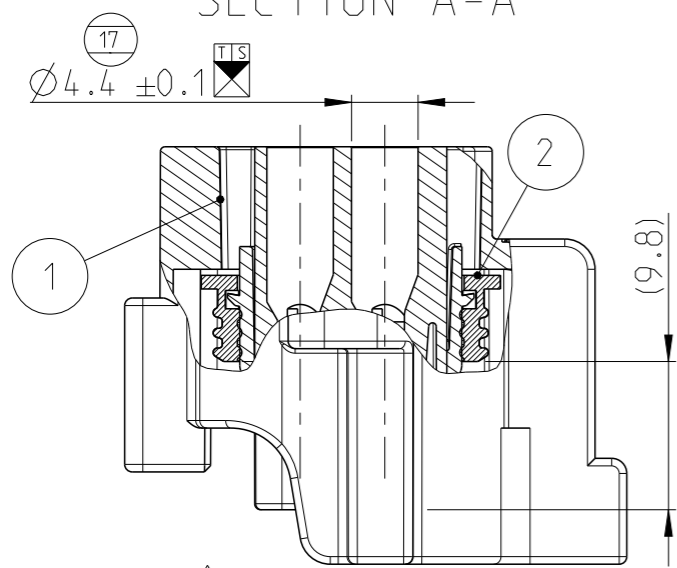

SCALE 1:1

SCALE 1:1

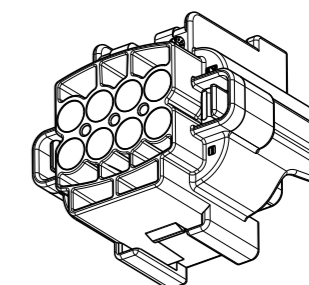
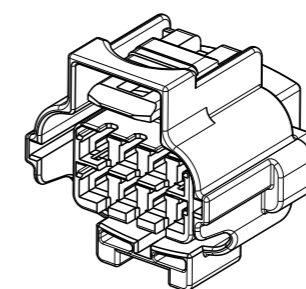

TE PART NO.	PART REV.	QTY.	MATERIAL	COLOR	DESCRIPTION	ITEM NO
2307642-1	B	1	SILICON	ORANGE	PERIPHERAL SEAL	2
	D	1	PBT	BLACK	8P PLUG HOUSING	1

THIS DRAWING IS A CONTROLLED DOCUMENT.	
DIMENSIONS: mm	TOLERANCES UNLESS OTHERWISE SPECIFIED: ±0.15
	0 PLC ± 1 PLC ± 2 PLC ± 3 PLC ± 4 PLC ± ANGLES ± FINISH -
MATERIAL SEE TABLE	

DWN	24OCT2016
CHK	CH.SANDESH
CHK	DANAPPA.H
APVD	V.V.BIDI
PRODUCT SPEC	108-94594
APPLICATION SPEC	114-94473
WEIGHT	8.9 g
CUSTOMER DRAWING	

		NAME		RESTRICTED TO
		8POS. PLUG HOUSING ASSEMBLY ECONOSEAL J-MARK CONNECTOR		
SIZE	CAGE CODE	DRAWING NO	-	
A3	-	©-2307642	-	
SCALE		SHEET	OF	REV
2:1		1	1	D