

THIS DRAWING IS UNPUBLISHED. RELEASED FOR PUBLICATION 20
 © COPYRIGHT 20 BY - ALL RIGHTS RESERVED.

REVISIONS				
P	LTR	DESCRIPTION	DATE	APVD
B		REV PER ECO 20-006304	9-26-20	CT DM

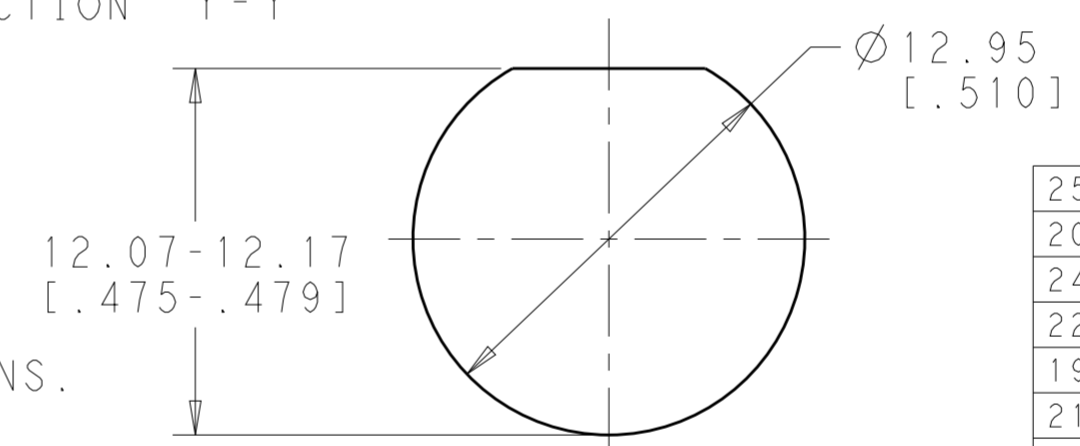

- TE MATING CONNECTOR PART NUMBER 2226910 MATCHING KEYING AND NUMBER OF POSITIONS.
- SHELL FINISH: SELECTIVE PLATE 12.7µm MIN ZINC-NICKEL OVER 12.7µm MIN ELECTROLESS NICKEL ALL OVER.
- ROHS COMPLIANT.
- MATERIALS: ALUMINUM ALLOY, THERMOPLASTIC AND FLUORSILICONE .
- CONNECTOR SHALL MEET ENVIRONMENTAL REQUIREMENTS PER MIL-STD-810G.
- ASSEMBLY ACCEPTS SIZE 23 SOCKET CONTACTS.
- CONTACT CURRENT RATING 5 AMPS CRIMPED TO 22AWG WIRES.
- CONNECTOR SHIPPED WITH DUST CAPS.
- CONNECTOR WEIGHT: 4.39 grams (W/O CONTACTS).
- MARKINGS PER MIL-STD-202, METHOD 215.
- CONTACTS ARE KITTED IN SEALED PLASTIC BAG AND SHIPPED UN-ASSEMBLED TO CONNECTOR.
- UNLESS OTHERWISE SPECIFIED, ALL DIMENSIONS ARE FOR REFERENCE ONLY.
- THIS DRAWING HAS UNLIMITED USAGE RIGHTS. SCALE 5

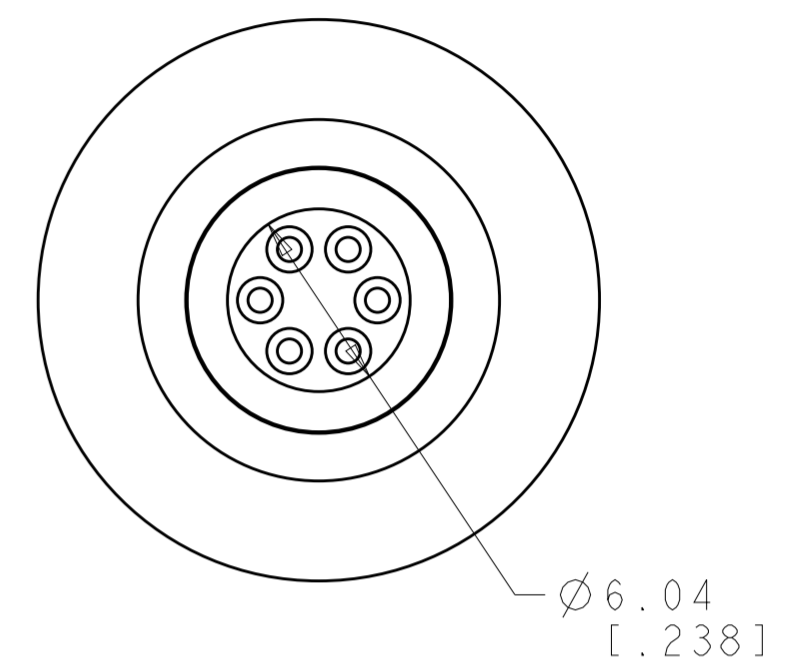
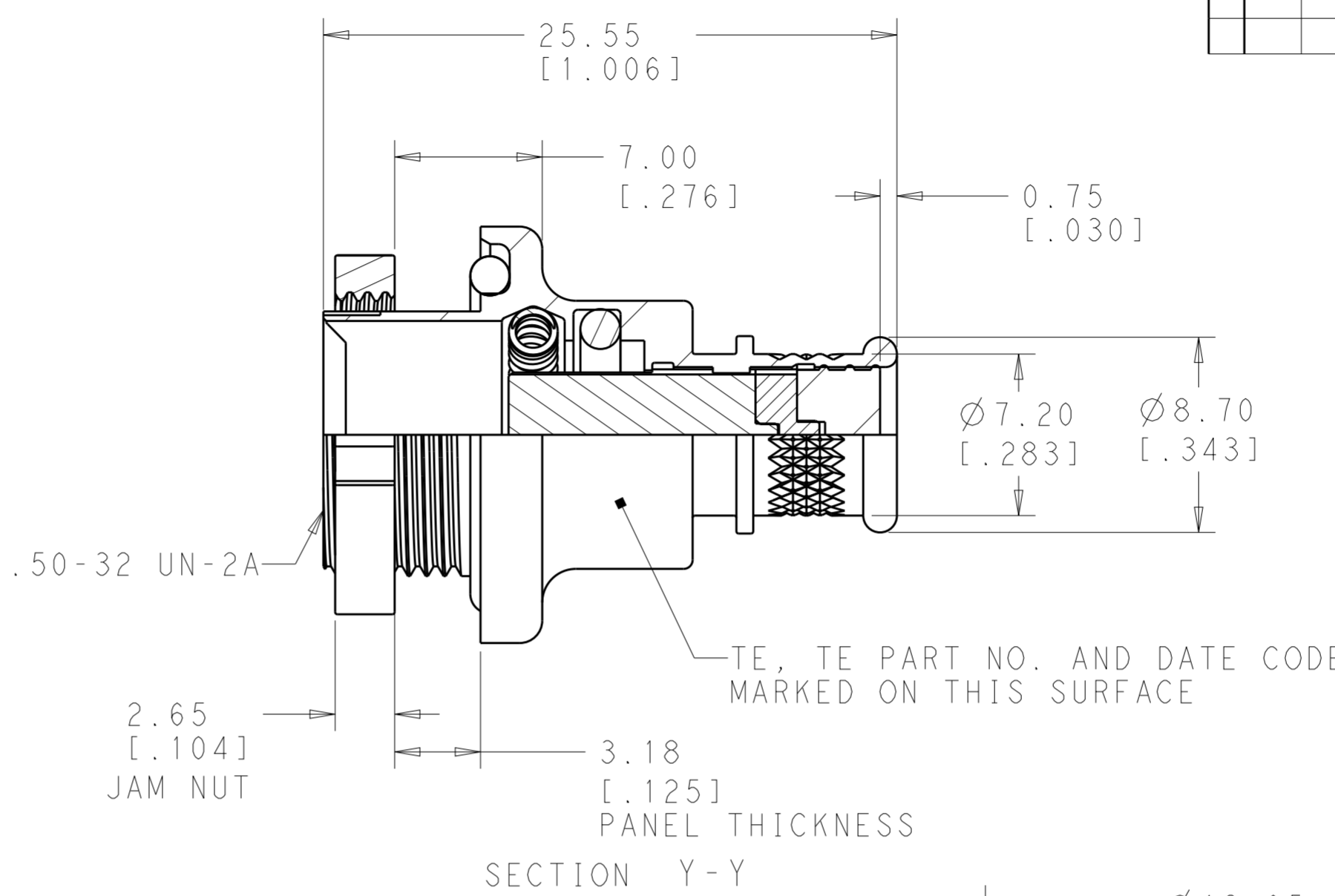
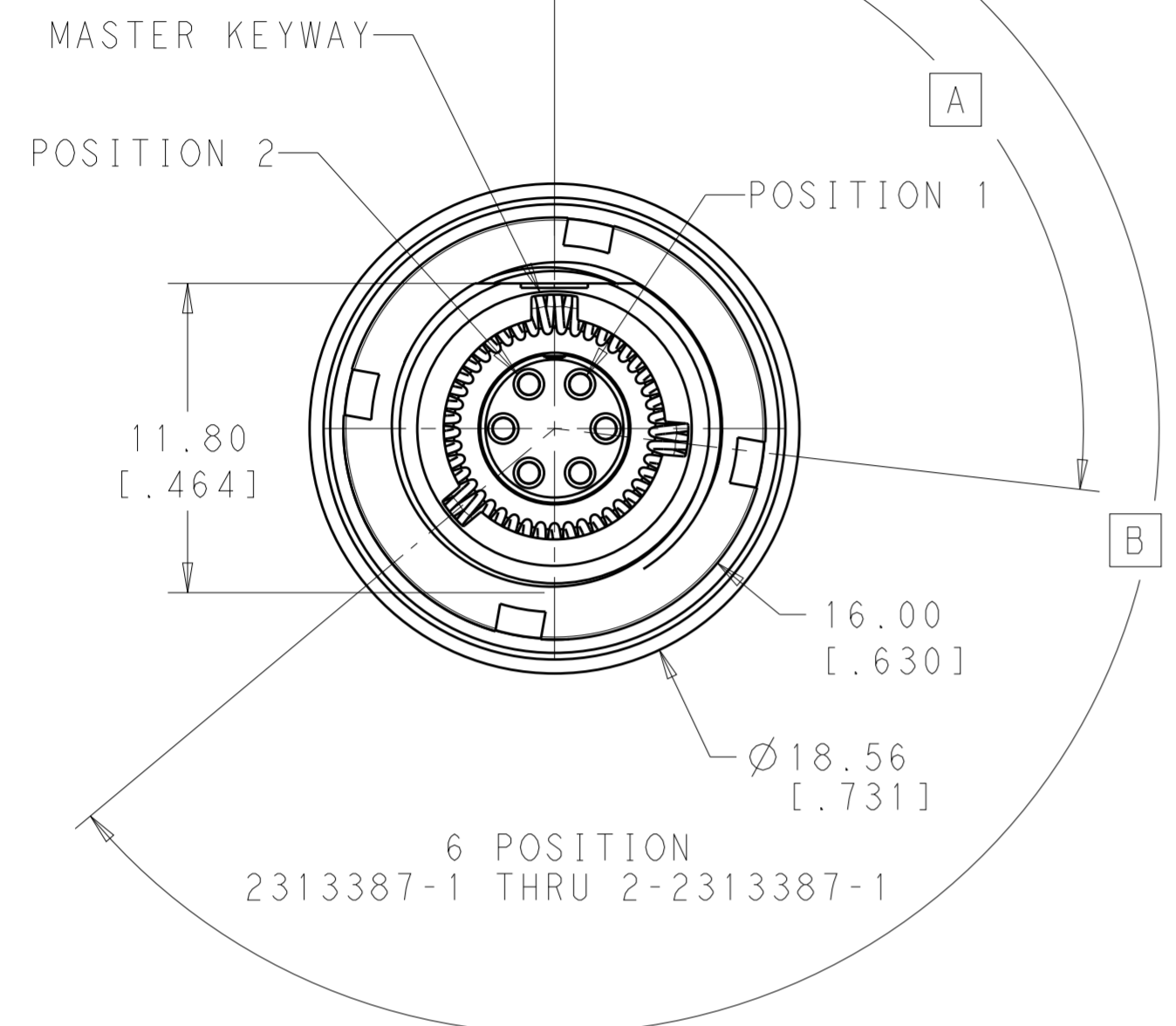
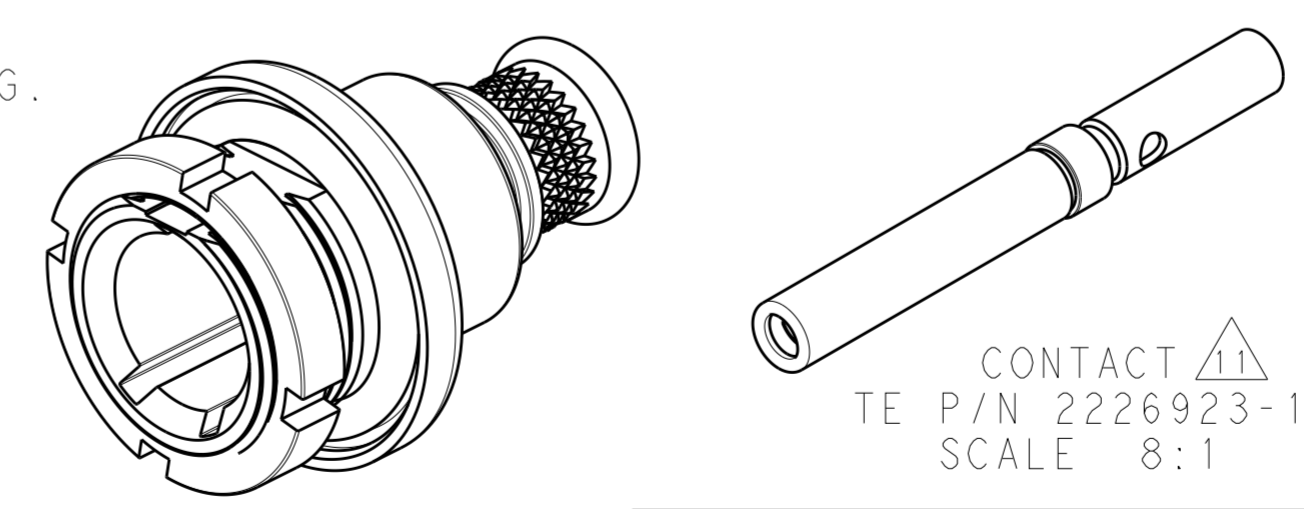

255	155	ME	7	4-2313387-3
205	105	MD	7	4-2313387-1
245	115	MC	7	3-2313387-9
220	140	MB	7	3-2313387-7
195	165	MA	7	3-2313387-5
210	95	F	7	3-2313387-3
275	75	E	7	3-2313387-1
275	140	D	7	2-2313387-9
210	75	B	7	2-2313387-7
210	150	A	7	2-2313387-5
230	95	C	7	2-2313387-3
255	155	ME	6	2-2313387-1
205	105	MD	6	1-2313387-9
245	115	MC	6	1-2313387-7
220	140	MB	6	1-2313387-5
195	165	MA	6	1-2313387-3
210	95	F	6	1-2313387-1
275	75	E	6	2313387-9
275	140	D	6	2313387-7
210	75	B	6	2313387-5
210	150	A	6	2313387-3
230	95	C	6	2313387-1
B	A	KEYING	POSITIONS	PART NO

THIS DRAWING IS A CONTROLLED DOCUMENT.

DWN	L. SIPE	03 JAN 2018
CHK	R. MULFINGER	03 JAN 2018
APVD	R. MULFINGER	03 JAN 2018

STE TE Connectivity

NAME: RECEPTACLE CONNECTOR ASSEMBLY
 PANEL MOUNT
 NETT WARRIOR

SIZE: A2 CAGE CODE: 00779 DRAWING NO: C-2313387 RESTRICTED TO: -

CUSTOMER DRAWING SCALE: 5:1 SHEET: 1 OF 2 REV: B

THIS DRAWING IS UNPUBLISHED. RELEASED FOR PUBLICATION 20
 © COPYRIGHT 20 BY - ALL RIGHTS RESERVED.

REVISIONS				
P	LTR	DESCRIPTION	DATE	APVD
-	-	SEE SHEET 1	-	-

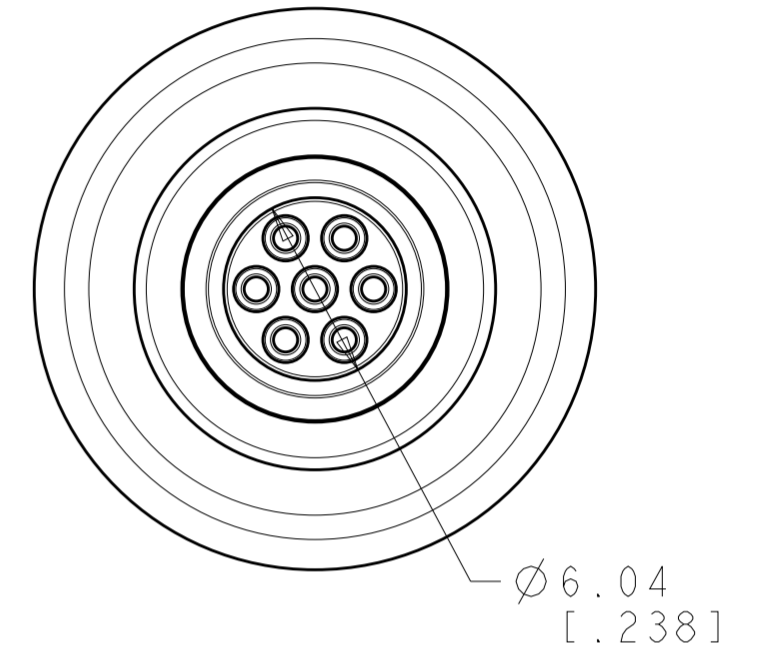
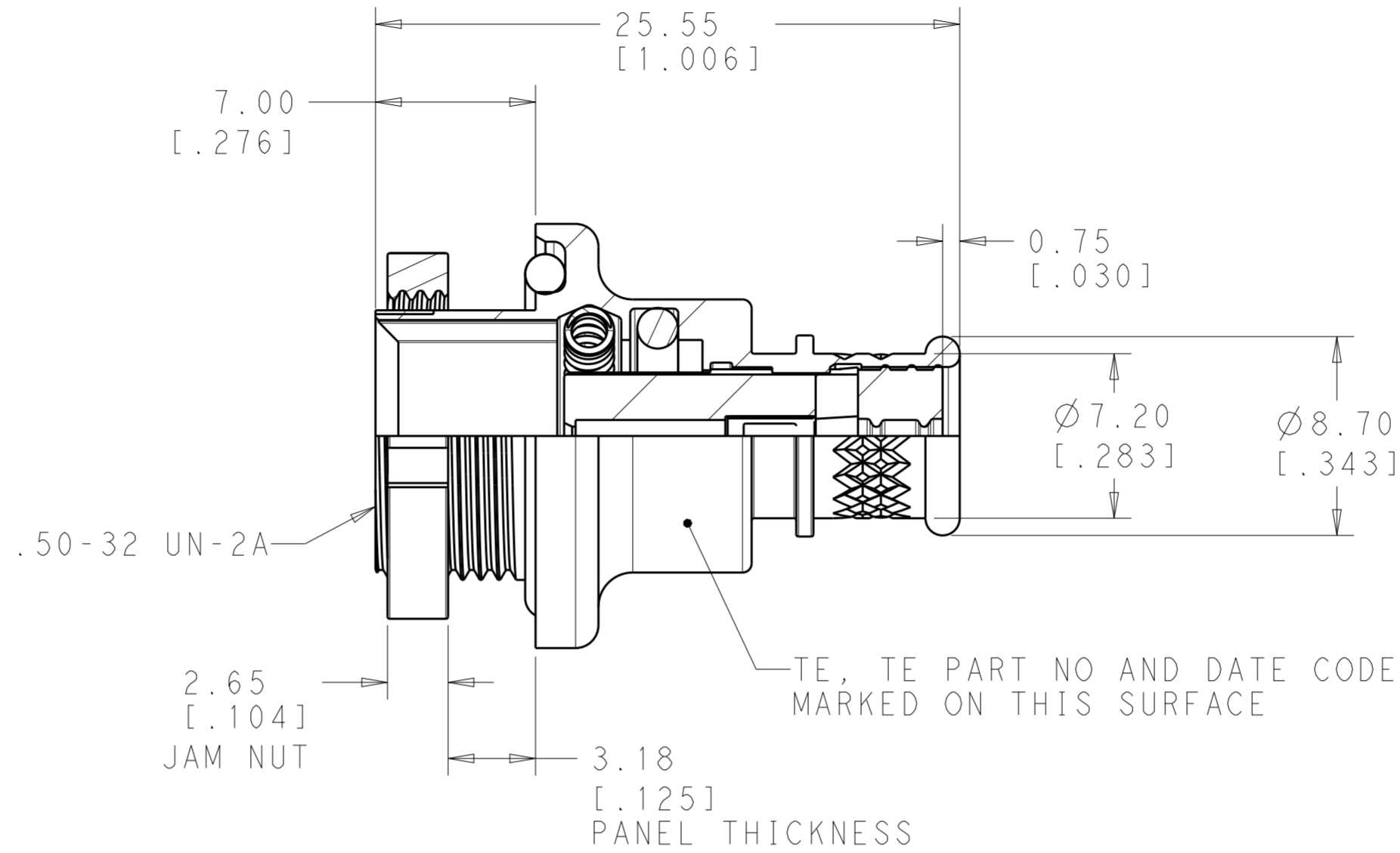
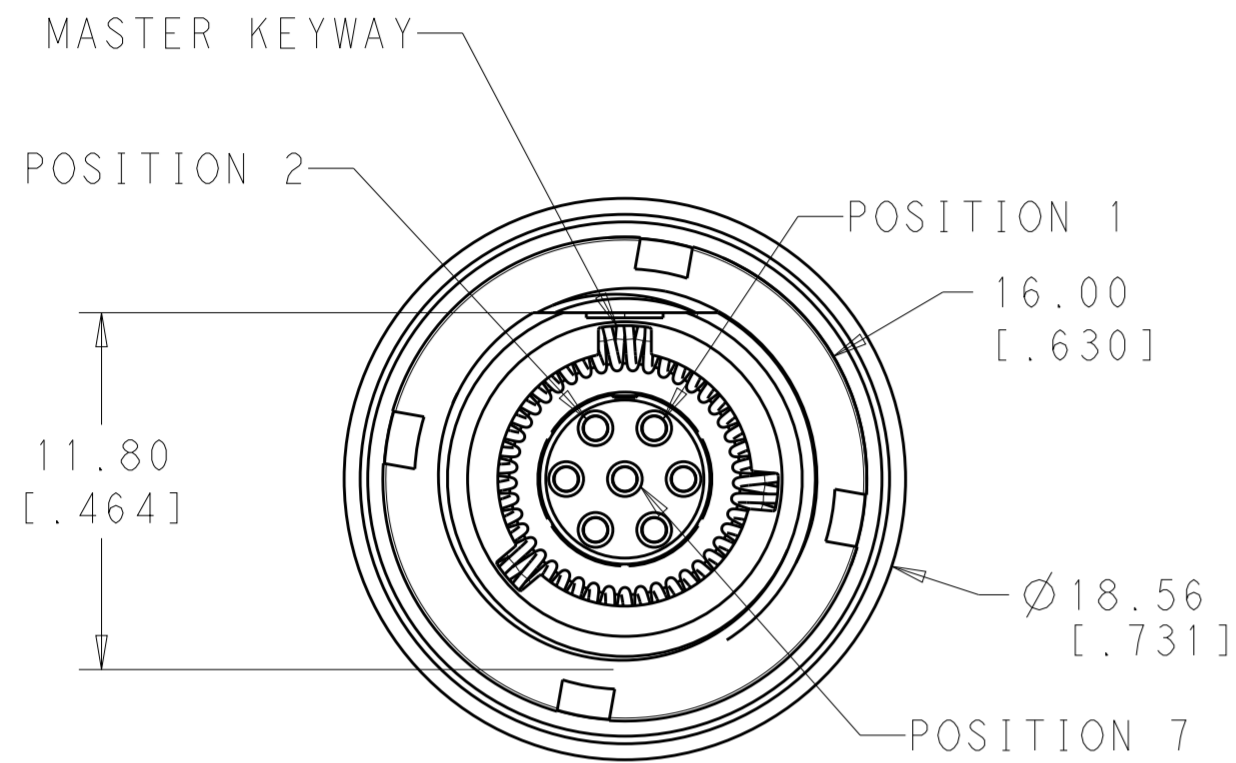

7 POSITION
 2-2313387-2 THRU 4-2313387-3

SECTION Y-Y

THIS DRAWING IS A CONTROLLED DOCUMENT.		DWN L. SIPE 03 JAN 2018	TE Connectivity	
DIMENSIONS: in		CHK R. MULFINGER 03 JAN 2018		
TOLERANCES UNLESS OTHERWISE SPECIFIED: 0 PLC ± 1 PLC ± 2 PLC ±0.02 3 PLC ±0.005 4 PLC ± ANGLES ± FINISH		APVD R. MULFINGER 03 JAN 2018	NAME RECEPTACLE CONNECTOR ASSEMBLY PANEL MOUNT NETT WARRIOR	
MATERIAL		PRODUCT SPEC	SIZE	RESTRICTED TO
-		APPLICATION SPEC	A200779	-
-		WEIGHT	C-2313387	-
-		CUSTOMER DRAWING	SCALE 5:1	SHEET 2 OF 2