

- 3 : AS SHOWN (本図)

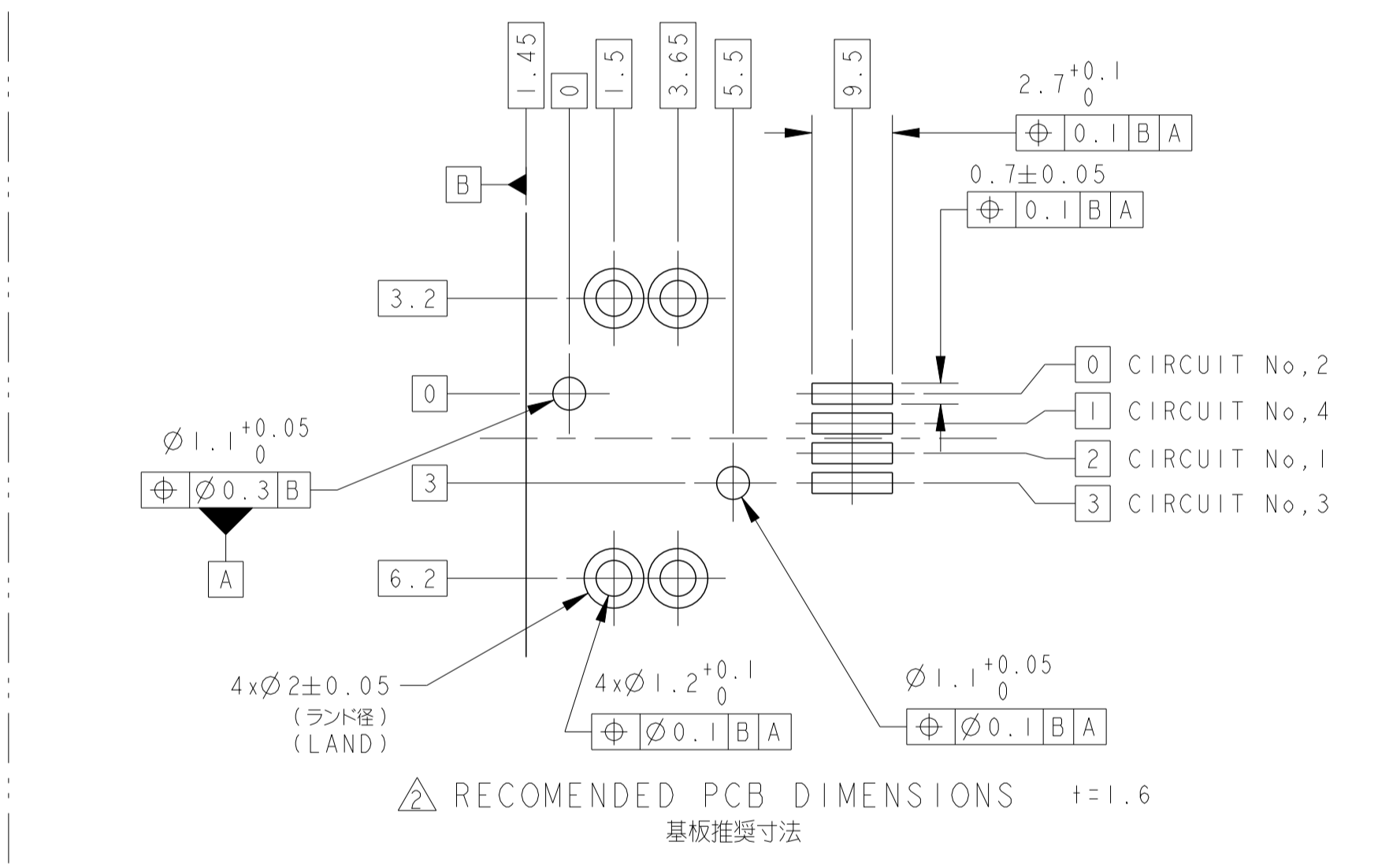
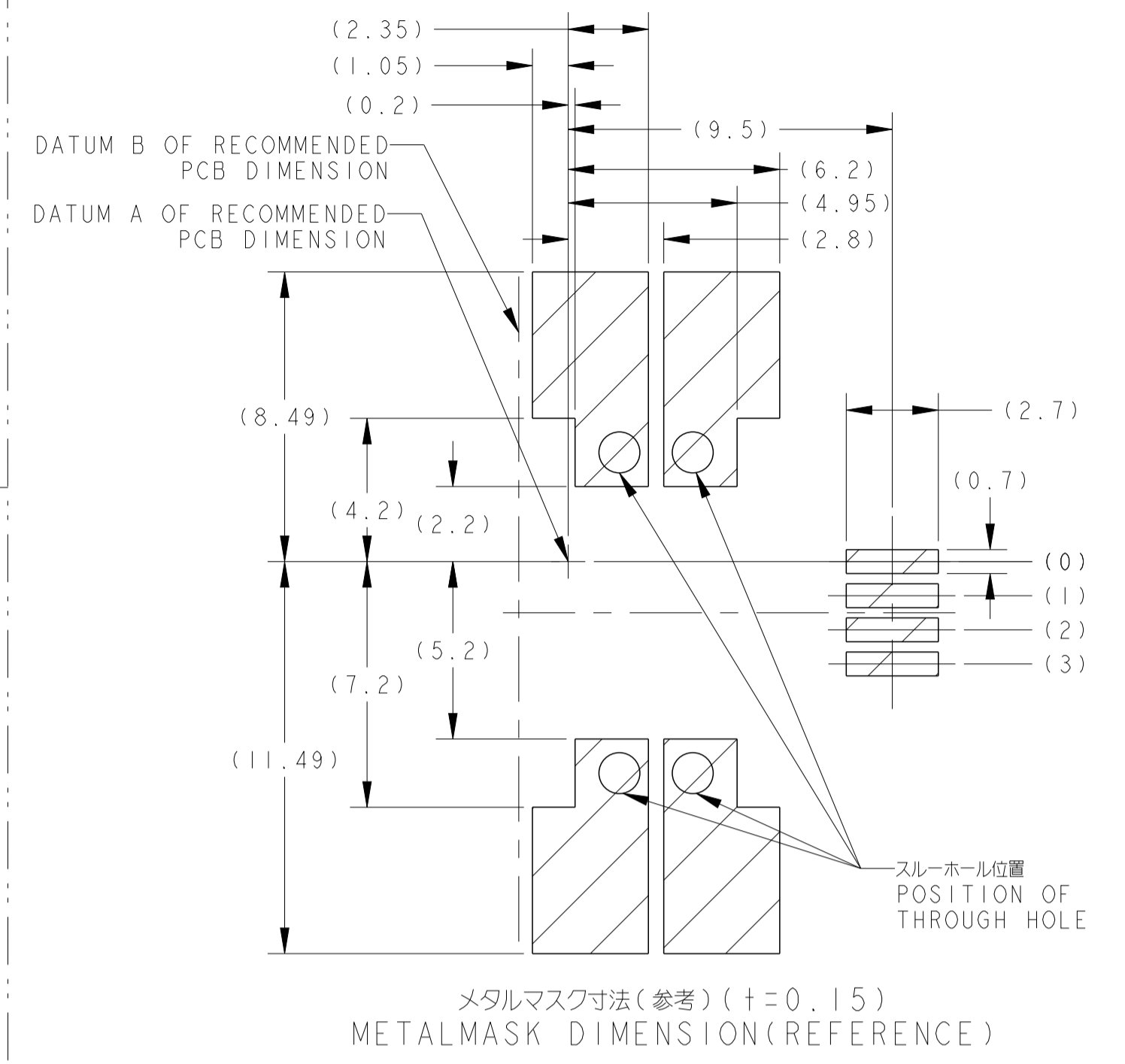
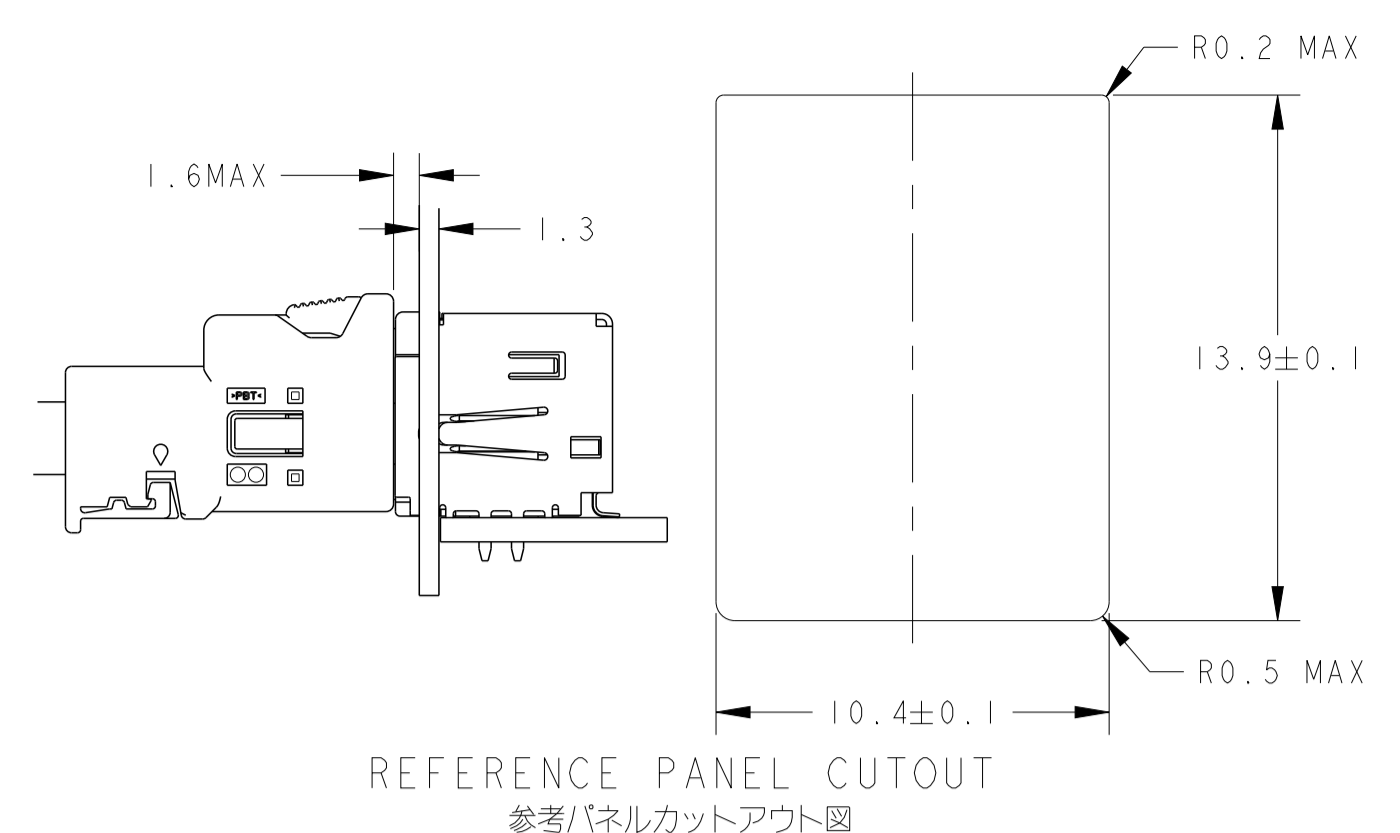
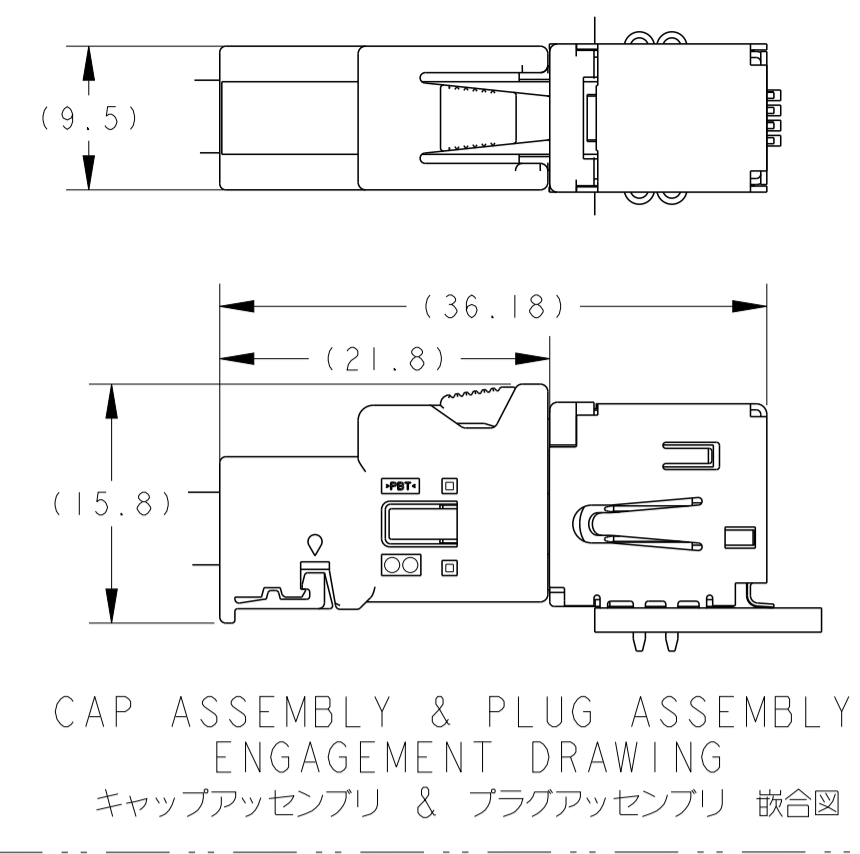
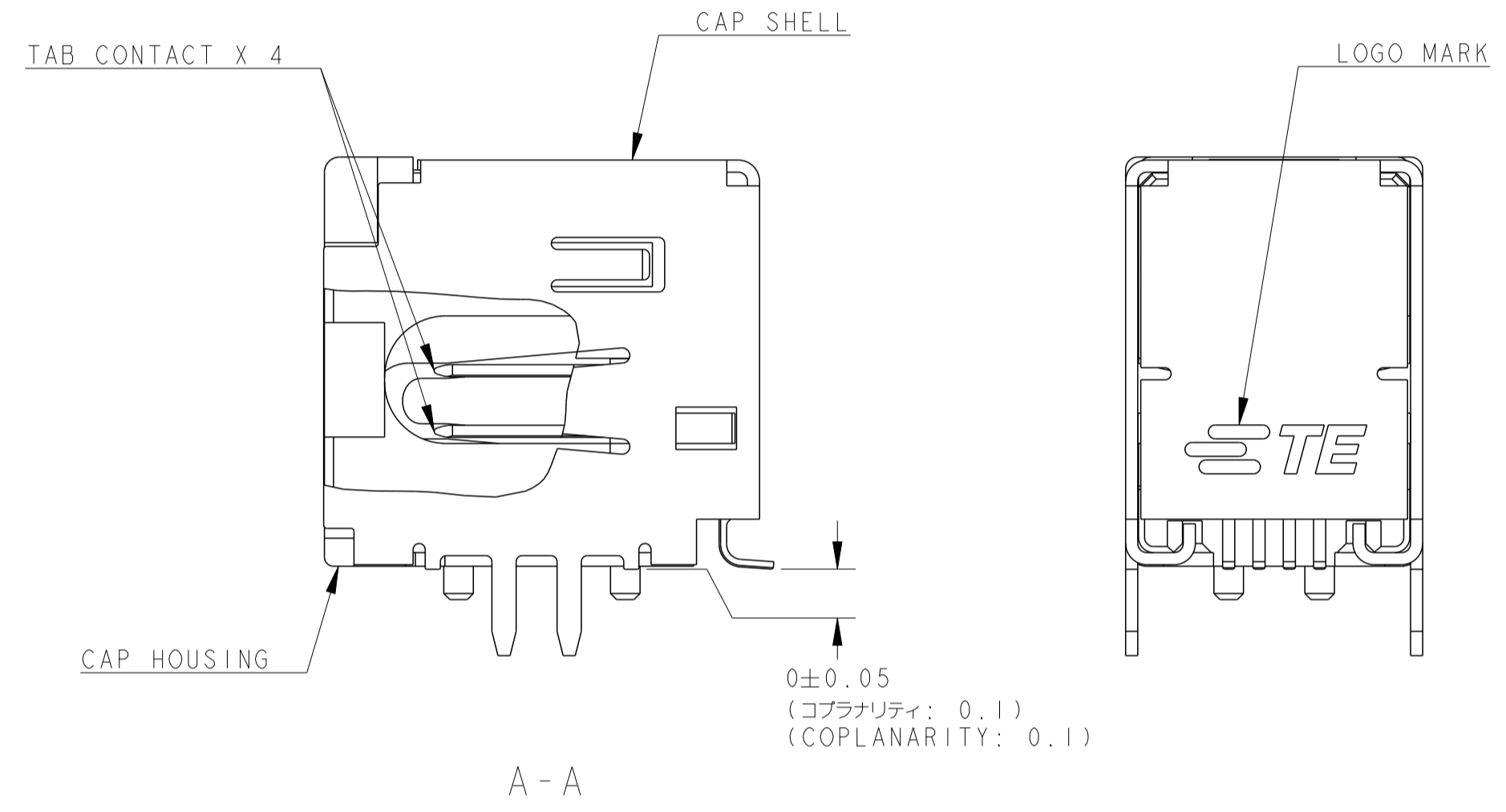
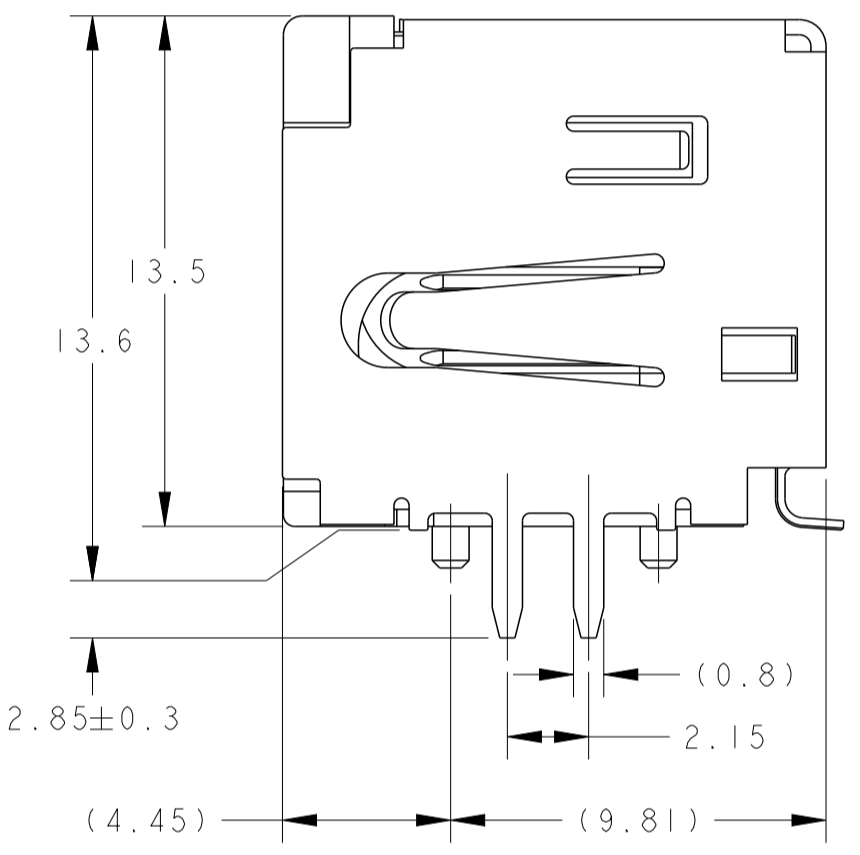
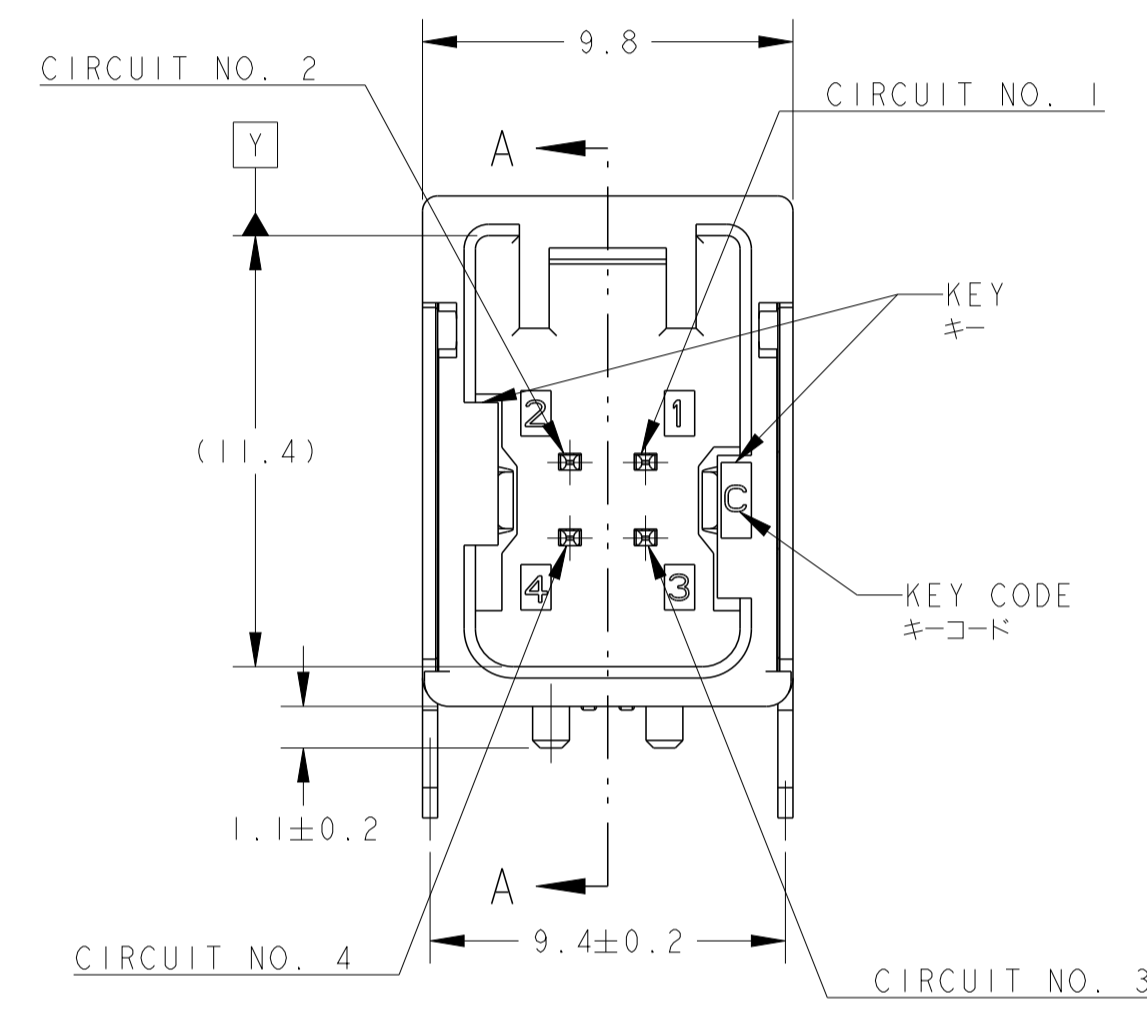
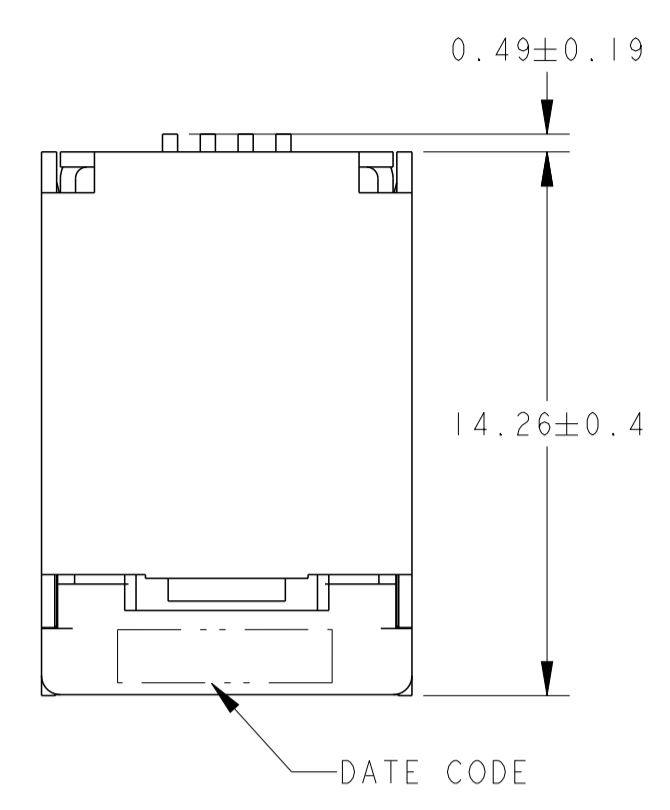

REVISONS				
REV	DATE	DESCRIPTION	BY	CHK
A	22AUG2018	RELEASED	SH	TK
B	28FEB2022	REVISED ECR-22-126808	SH	TY
B1	10AUG2023	REVISED ECR-23-183812	SH	TK
B2	5SEP2023	REVISED ECR-23-186802	SH	TK

PN	2317581-3, 1-2317581-3	2317581-4
PRODUCT FORM		
KEY TYPE	C	D
MATED CONNECTOR	SEE 408-78158	

△.SEE TABLE 1 IN THE INSTRUCTION SHEET, 408-78158, TO REFER PLUG COMPONENTS TO BE MATED.  
 2.SEE 108-140185 FOR PRODUCTION SPEC OF MECHANICAL PERFORMANCE.  
 3.SEE 108-140202 FOR PRODUCTION SPEC OF SIGNAL TRANSMISSION PERFORMANCE.  
 △.嵌合相手のプラグコンポーネントについては、TABLE 1 記載の取扱説明書408-78158を参照のこと。  
 2. 製品の機械的性能は製品規格 108-140185を参照のこと。  
 3. 製品の伝送特性は製品規格 108-140202を参照のこと。

PAPER BOX	TAPE&REEL	POST-TIN	COPPER ALLOY	POST-TIN	BRASS	PPS	NATURAL	KEY C	1-2317581-3
ダンボール箱	△テープ&リール	後鍍めつき	銅合金	後鍍めつき	黄銅	PPS	NATURAL	KEY C	1-2317581-3
PAPER BOX	△ソフトトレイ	後鍍めつき	COPPER ALLOY	後鍍めつき	BRASS	PPS	BROWN	KEY D	2317581-4
ダンボール箱	△ソフトトレイ	後鍍めつき	COPPER ALLOY	後鍍めつき	黄銅	PPS	NATURAL	KEY C	2317581-3
分装	内装	仕上げ	材料	仕上げ	材料	材料	COLOR	KEY TYPE	PART NO.
梱包形態	CAP SHELL	TAB CONTACT	CAP HOUSING	キータイプ	製品番号				

THIS DRAWING IS A CONTROLLED DOCUMENT.		DWN	S. HIROTA	22AUG2018
DIMENSIONS: mm		CHK	T. YAMAMOTO	22AUG2018
TOLERANCES UNLESS OTHERWISE SPECIFIED:		APVD	T. KIMURA	22AUG2018
0-PLE	±0.3	NAME	CAP ASSEMBLY	
1-PLE	±0.5	PRODUCT SPEC	4POS, RIGHT ANGLE	
2-PLE	±0.5	SEE NOTE	0.50 HSL CONNECTER	
3-PLE	±0.13	APPLICATION SPEC	SIZE	CAGE CODE
4-PLE	±0.001	角	A100779	DRAWING NO
ANGLES	±0.001	重	3.1g	2317581
FINISH	±3°00'	重量	CUSTOMER DRAWING	
SEE TABLE		材料	SEE TABLE	
SEE TABLE		仕上げ	SEE TABLE	
SEE TABLE		重量	SEE TABLE	
SEE TABLE		重量	SEE TABLE	

THIS DRAWING IS UNPUBLISHED.

RELEASED FOR PUBLICATION

© COPYRIGHT

ALL RIGHTS RESERVED.

REVISIONS

P	LTR	DESCRIPTION	DATE	DWN	APVD
		SEE SHEET 1			

TRAY PACKING / トレイ梱包

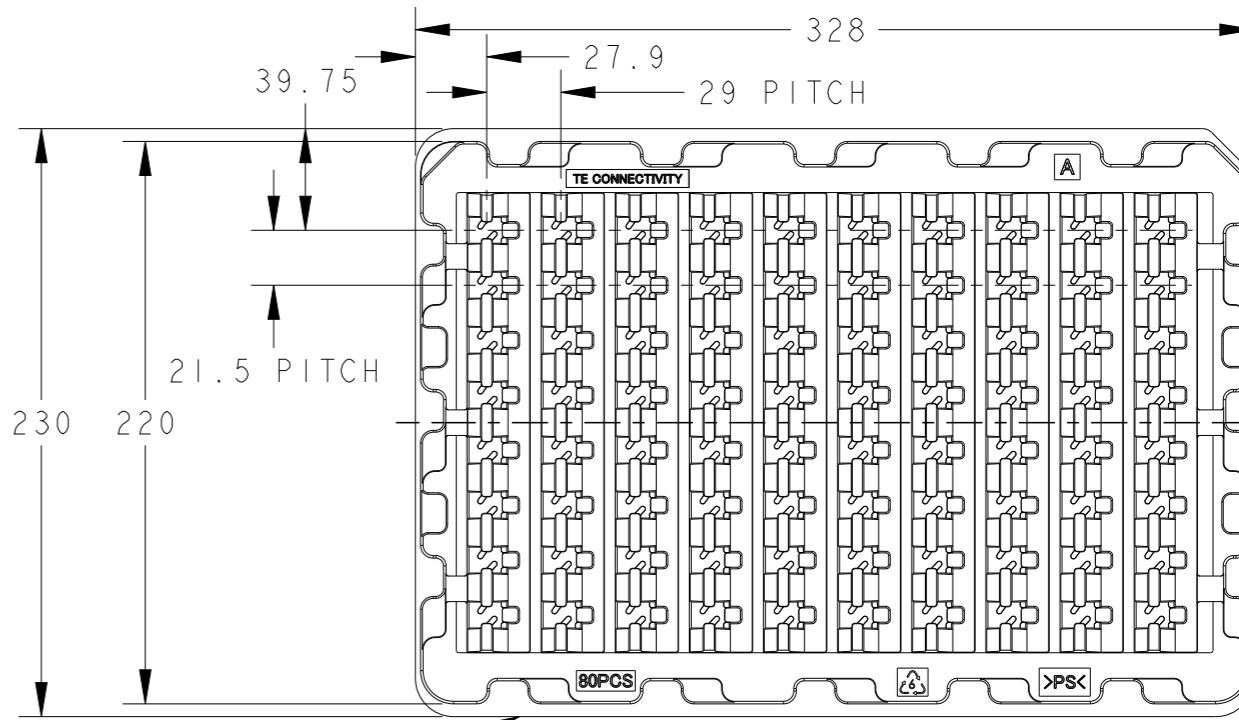
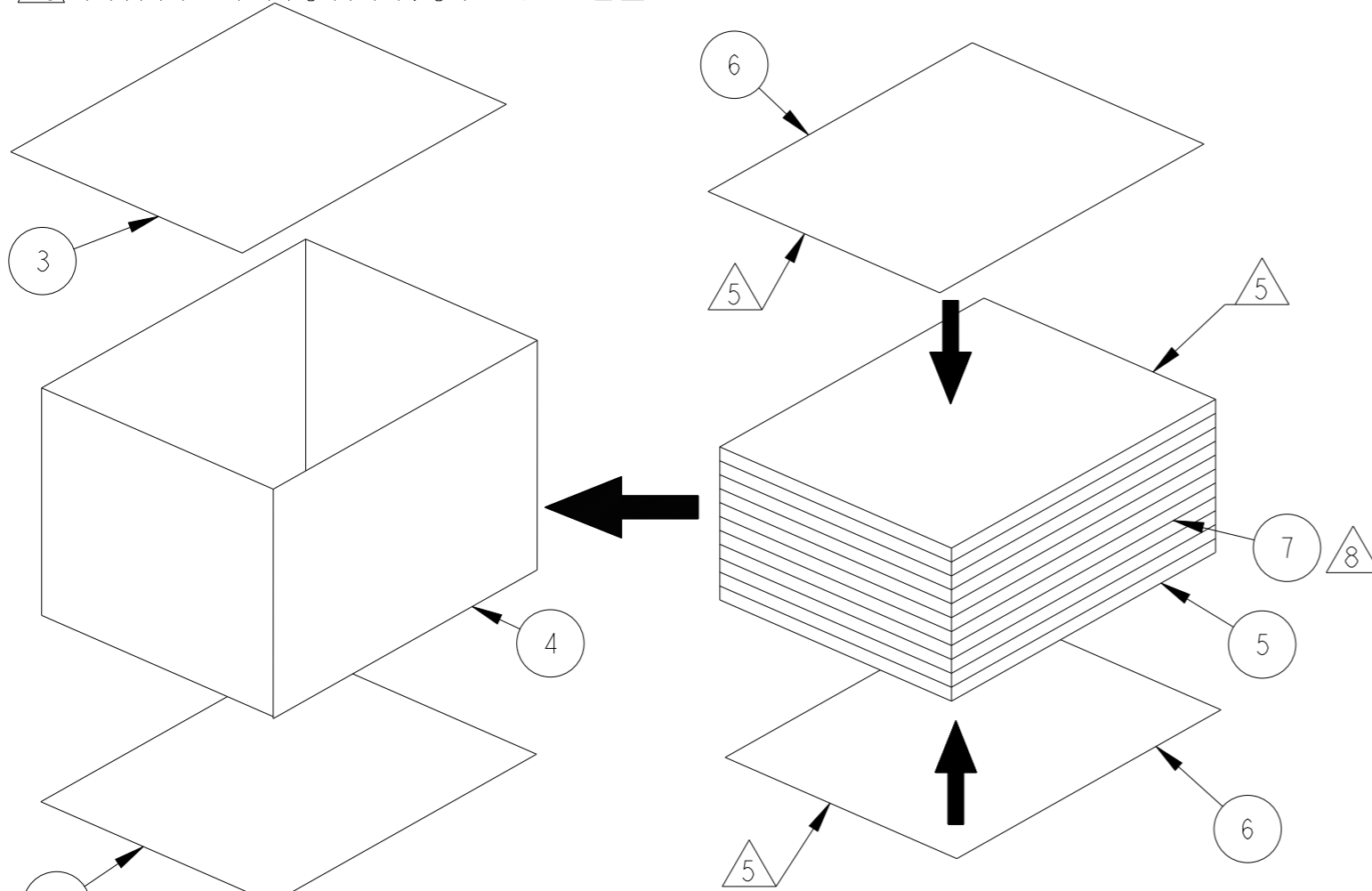

- 4 QTY OF PRODUCT;  
1 TRAY = 80PCS  
1 BOX = 800PCS, 11 TRAYS (TOP TRAY IS EMPTY)
- 5 CORRUGATED FIBERBOARD ON TRAY AND SECURE 11 TRAYS WITH TAPE.
- 6 TRAY HEIGHT; (20mm)
- 7 TRAY MATERIAL; PS
- 8 SET UP MIRROR MAT BETWEEN TRAY AND TRAY.

- 4 製品個数  
1 トレイ = 80個
- 5 1箱 = 800個、11トレイ (最上段に空トレイ)  
段ボール板をトレイの上下にセットし、テープでトレイを固定する。
- 6 トレイ高さ: (20mm)
- 7 トレイ材質: PS
- 8 トレイ間にミラーマットを設置する。

TABLE 2

QTY 個数	DESCRIPTION 品名	ITEM 項目
10	MIRROR MAT ミラーマット	7
2	CORRUGATED FIBERBOARD 段ボール板	6
11	TRAY トレイ	5
1	PE BAG プラスチック袋	4
4	AIR CAP エアキャップ	3
4	EDGE BOARD 補強材	2
1	PAPER BOX 段ボール箱	1

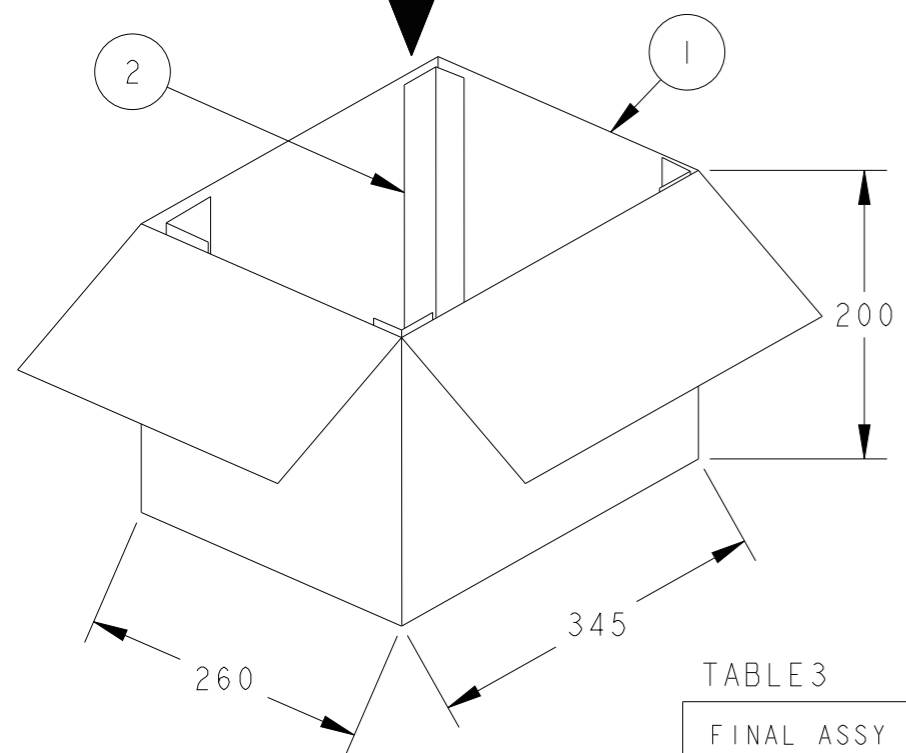

TABLE 3

FINAL ASSY P/N	WEIGHT[kg]/BOX 重量[kg]/箱
2317581-3	(4.2)
2317581-4	(4.2)

THIS DRAWING IS A CONTROLLED DOCUMENT.		DWN
DIMENSIONS: mm		CHK
TOLERANCES UNLESS OTHERWISE SPECIFIED: ± 5		APVD
0-PLC ±	1-PLC ±0.5	PRODUCT SPEC
2-PLC ±0.13	3-PLC ±0.013	APPLICATION SPEC
4-PLC ±0.0001	ANGLES ± 3°00'	WEIGHT
MATERIAL	FINISH	SEE TABLE 3

**STE** TE Connectivity

NAME  
CAP ASSEMBLY  
4POS, RIGHT ANGLE  
0.50 HSL CONNECTER

SIZE	CAGE CODE	DRAWING NO	RESTRICTED TO
A300779	C-2317581		-

CUSTOMER DRAWING      SCALE NTS      SHEET 2 OF 3      REV B2

REVISIONS				
REV	DATE	BY	CHK	APPV
1				

TAPE & REEL / テープ & リール梱包

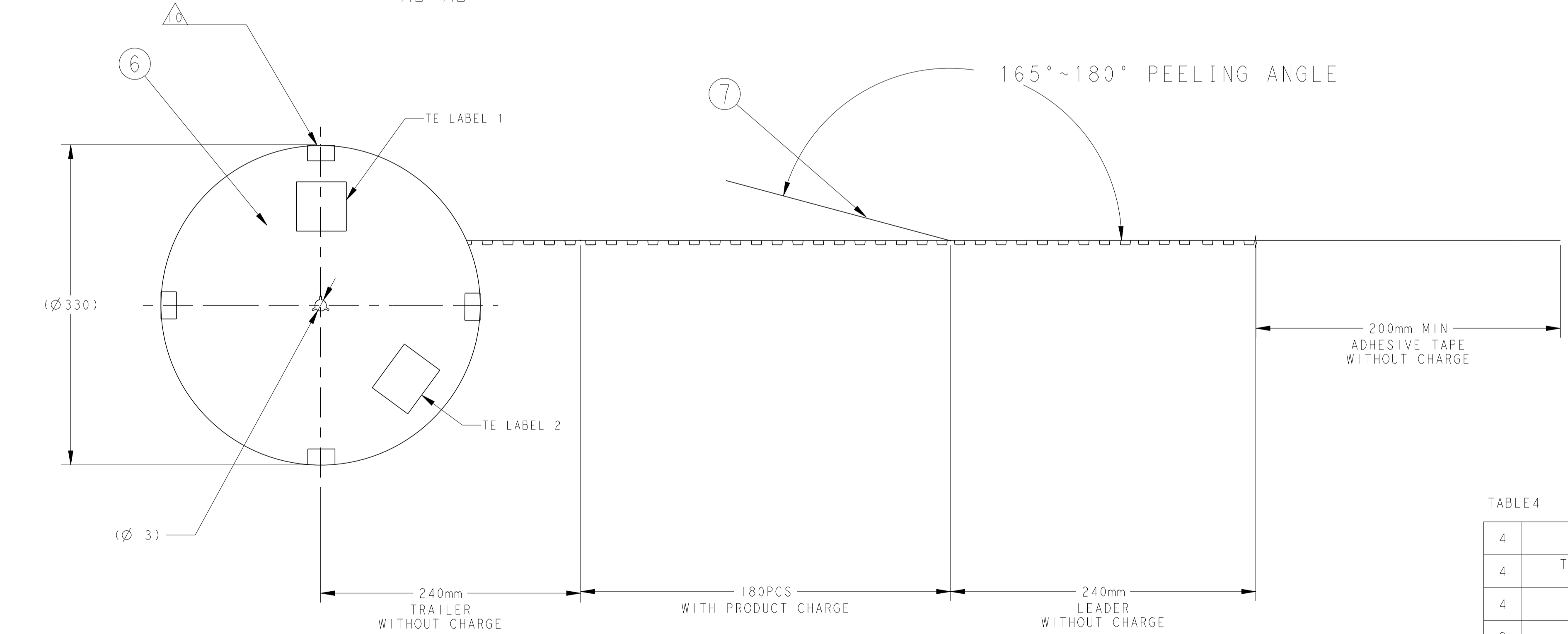
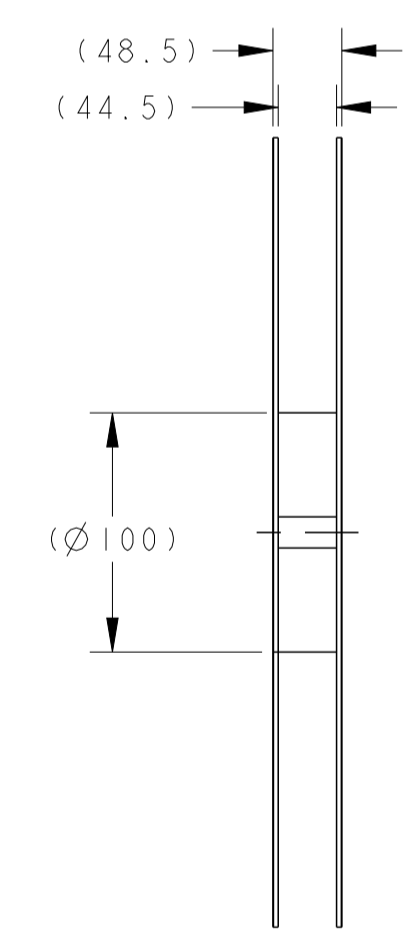
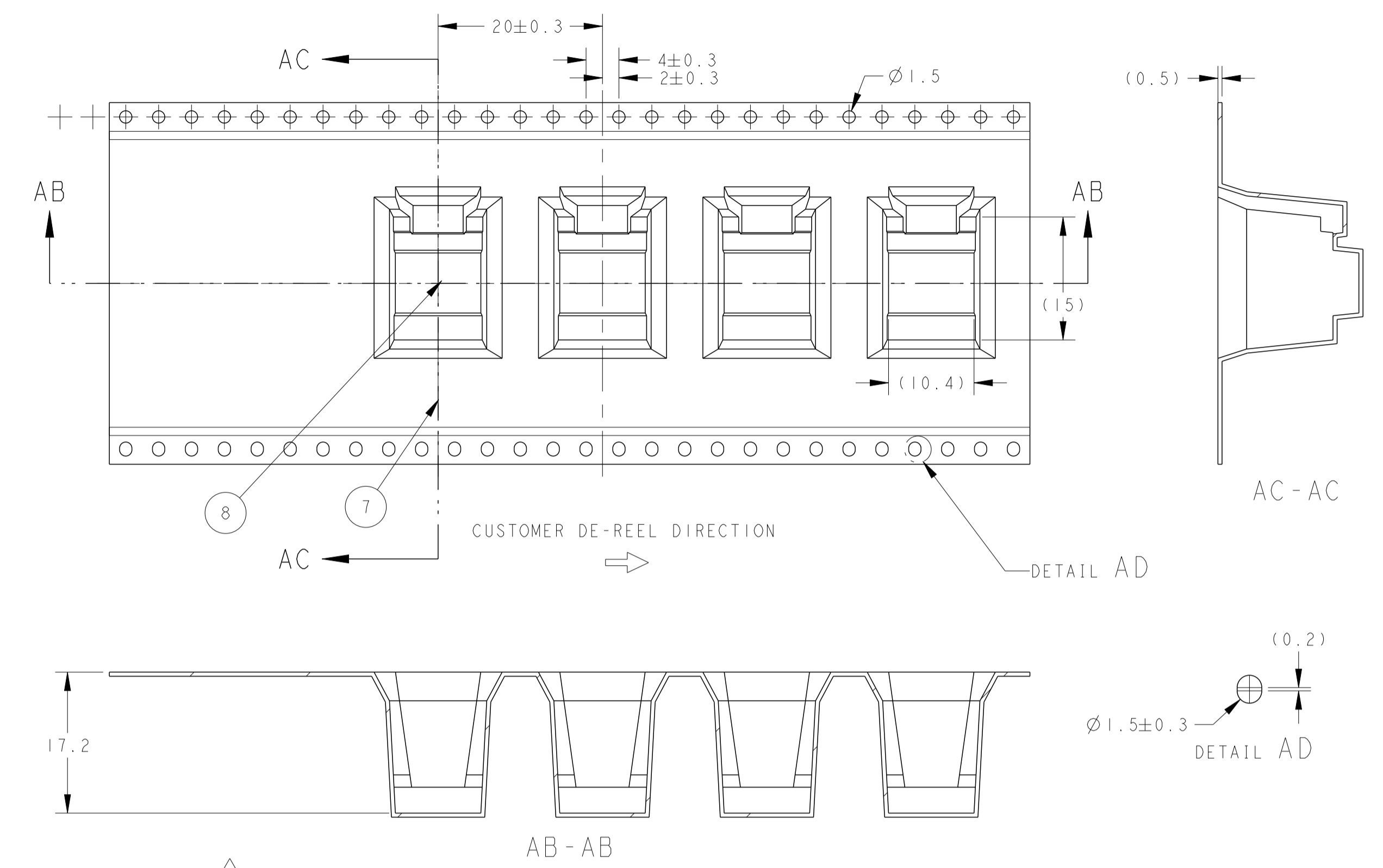
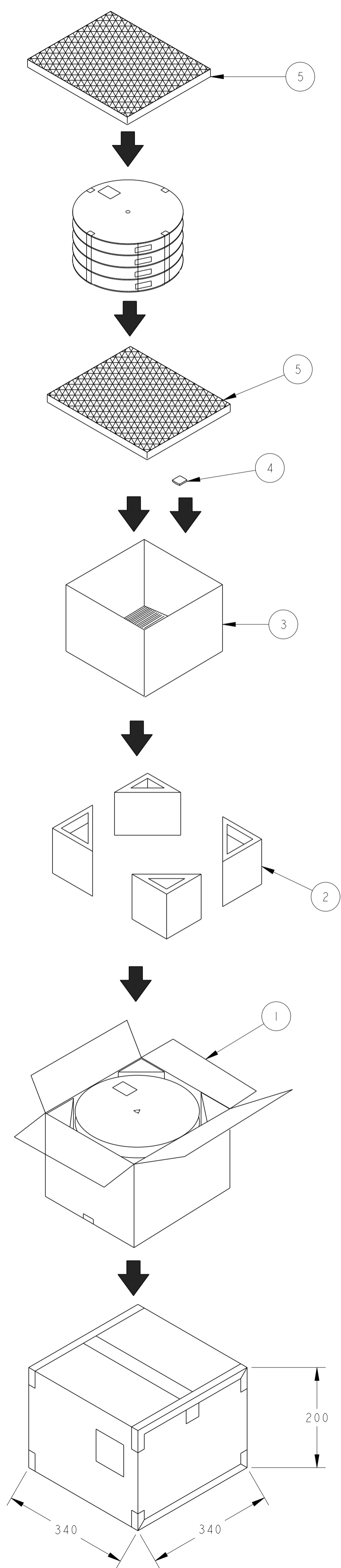

9. QTY OF REEL:  
 1 REEL = 180PCS  
 1 BOX = 720PCS, 4 REELS
- △ SECURE 4 REELS WITH TAPE AT 4 PLACE.
11. PEELING SPEED: 300mm/min  
 12. EMBOSS PACKING MATERIAL: CONDUCTIVE POLYSTYRENE  
 15. COVER MATERIAL: PET  
 16. TOP COVER TAPE PEELING FORCE SHALL BE BETWEEN 0.1N AND 1.3N BASED ON JIS C 0806-3 2021.
9. 製品個数  
 1リール = 180個  
 1箱 = 720個, 4リール
- △ 4箇所にテープを巻り4リールを固定
11. テープ剥離速度: 300mm/min  
 12. エンボステープ材質: 導電性ポリスチレン  
 15. カバー材質: PET  
 16. テープ接着強度: 0.1N~1.3N (JIS C 0806-3準拠)

TABLE 4

QTY	DESCRIPTION	ITEM
4	EMBOSS TAPE エンボステープ	8
4	TOP COVER TAPE カバーテープ	7
4	PLASTIC REEL プラスチックリール	6
2	BUBBLE SHEET バツファシット	5
1	SILICA GEL シリカゲル	4
1	PE BAG プラスチック袋	3
4	EDGE BOARD 補強材	2
1	PAPER BOX 段ボール	1

THIS DRAWING IS A CONTROLLED DOCUMENT.

TE Connectivity

CAP ASSEMBLY  
 4POS, RIGHT ANGLE  
 0.50 HSL CONNECTER

SIZE: A1 CAGE CODE: 00779 DRAWING NO: 2317581

RESTRICTED CUSTOMER

TABLE 5

FINISH GOODS P/N	WEIGHT[kg]/BOX 重量[kg]/箱
1-2317581-3	(4.2)