

REVISIONS			
REV	DATE	BY	APPD
2	20200217	AP	BA
A	20200218	CJ	CJ
A1	20200219	CJ	PR
A2	20200219	CJ	CJ

EXPLODED VIEW

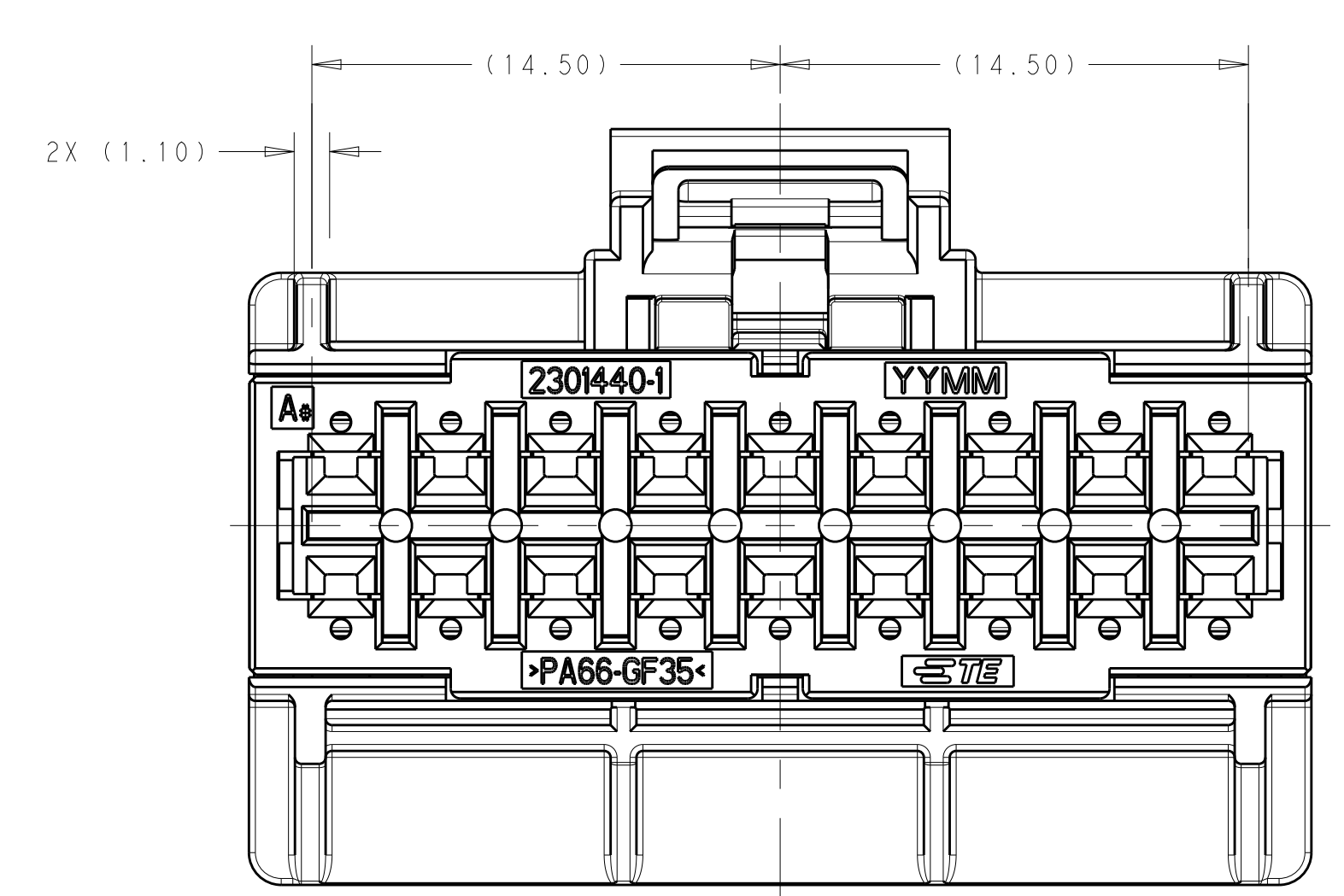

KEY CODE A

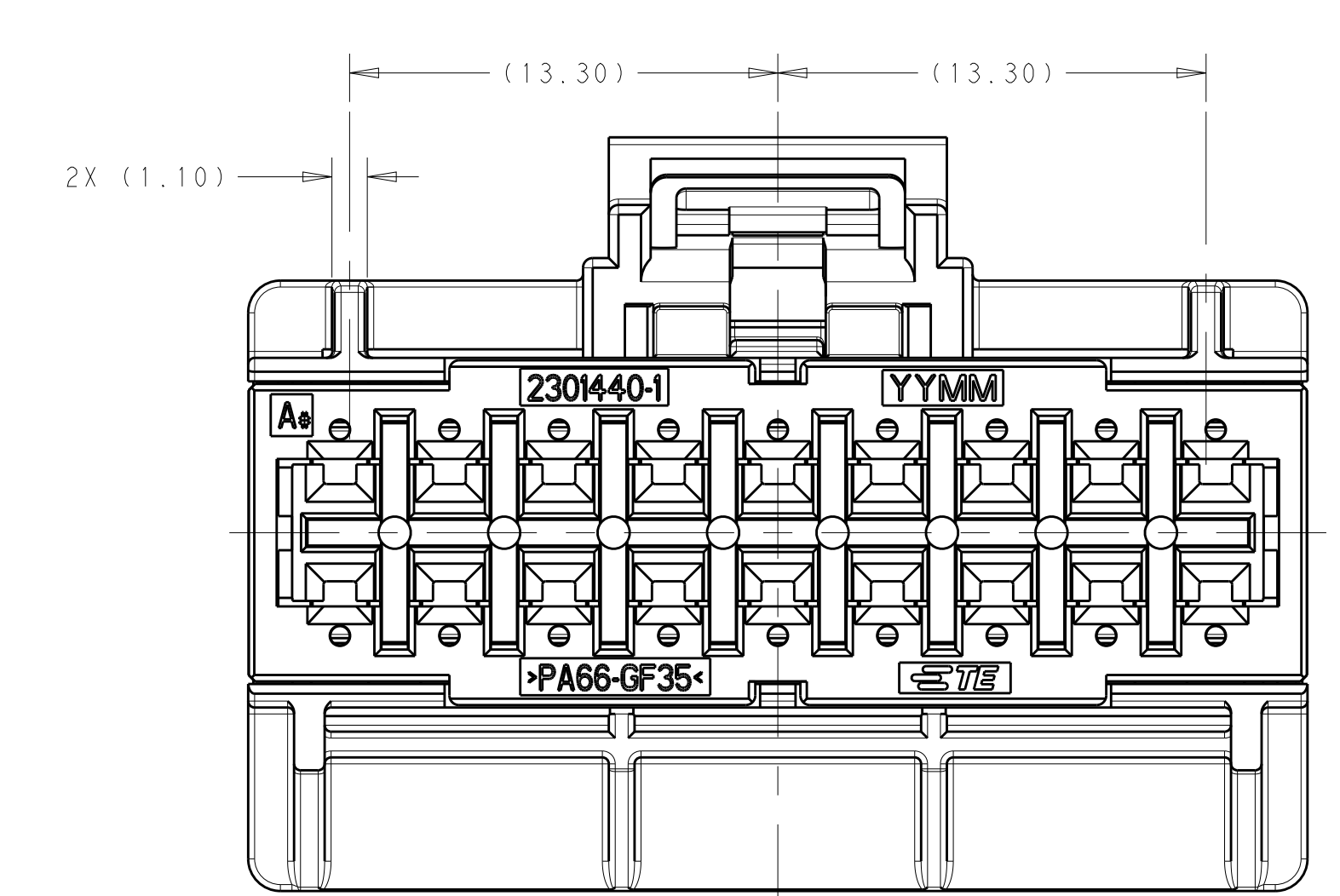

KEY CODE B

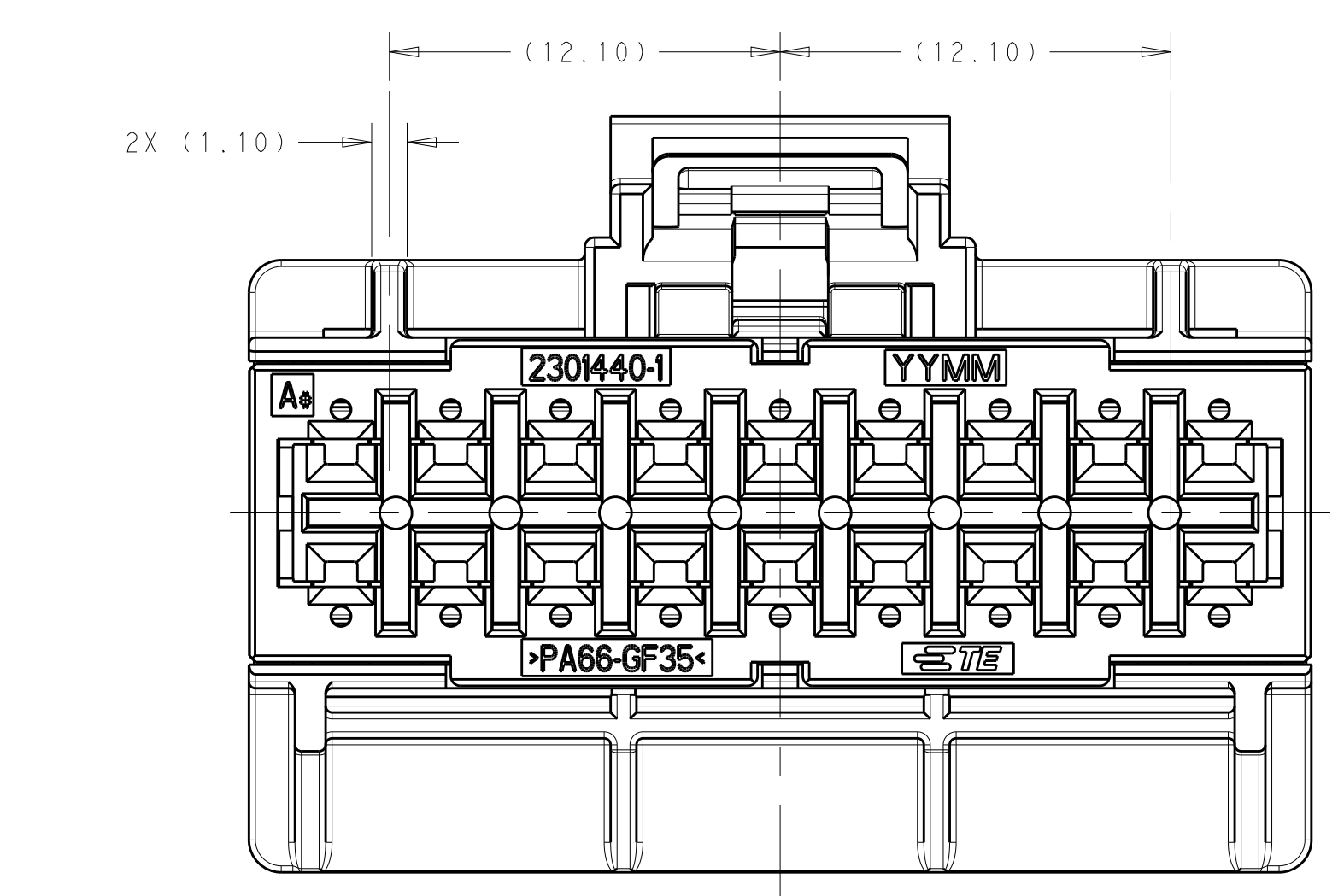

KEY CODE C

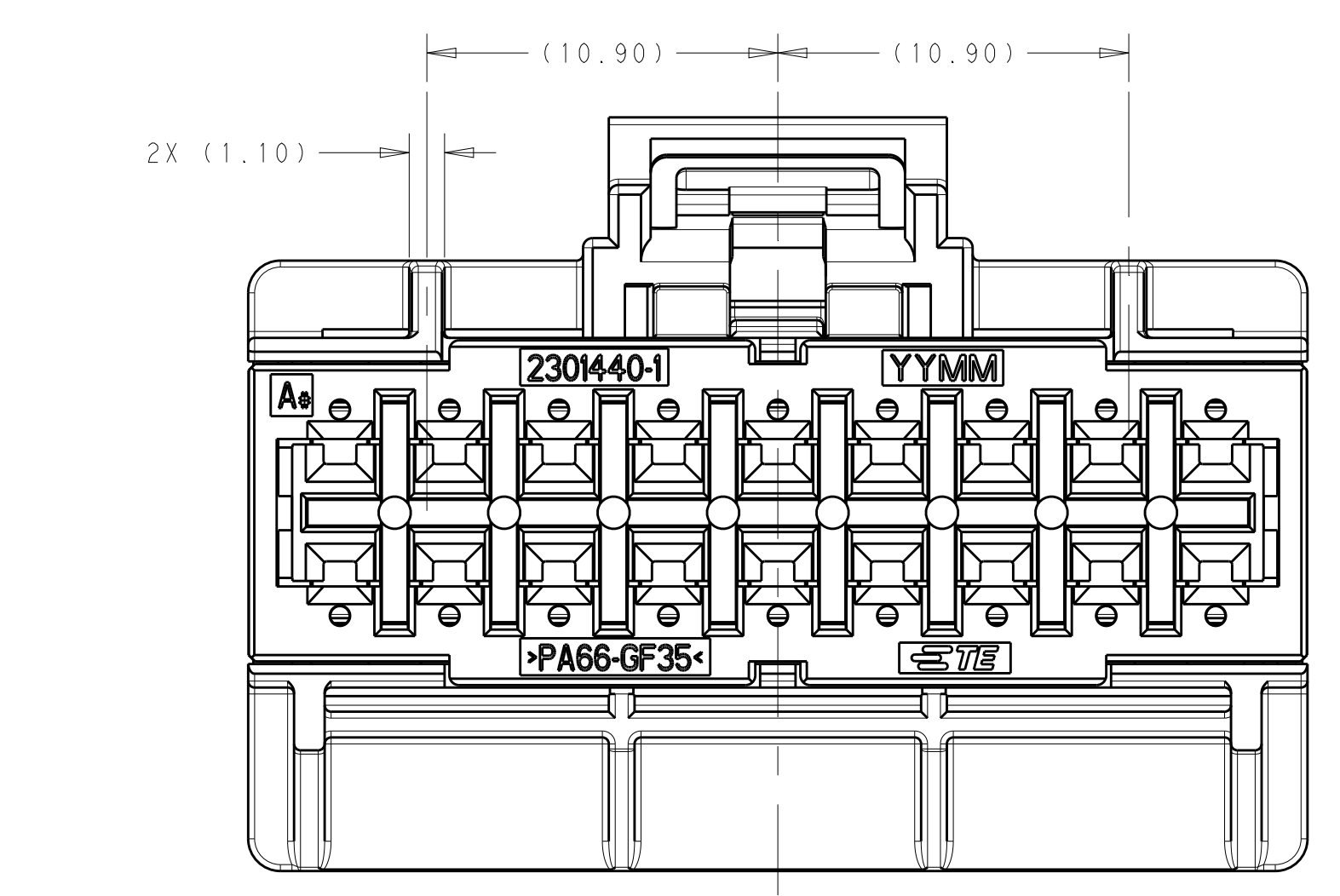

KEY CODE D

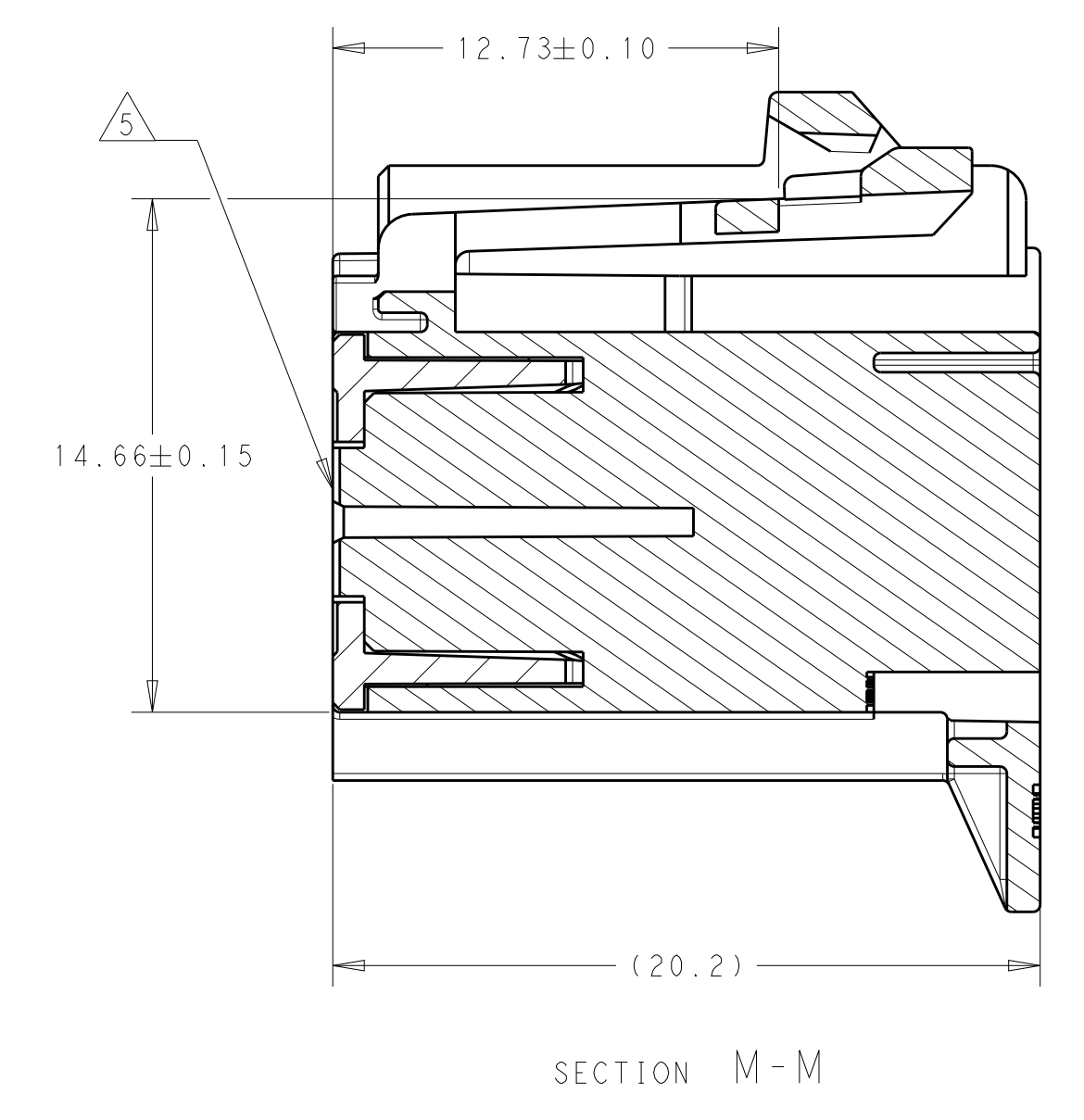
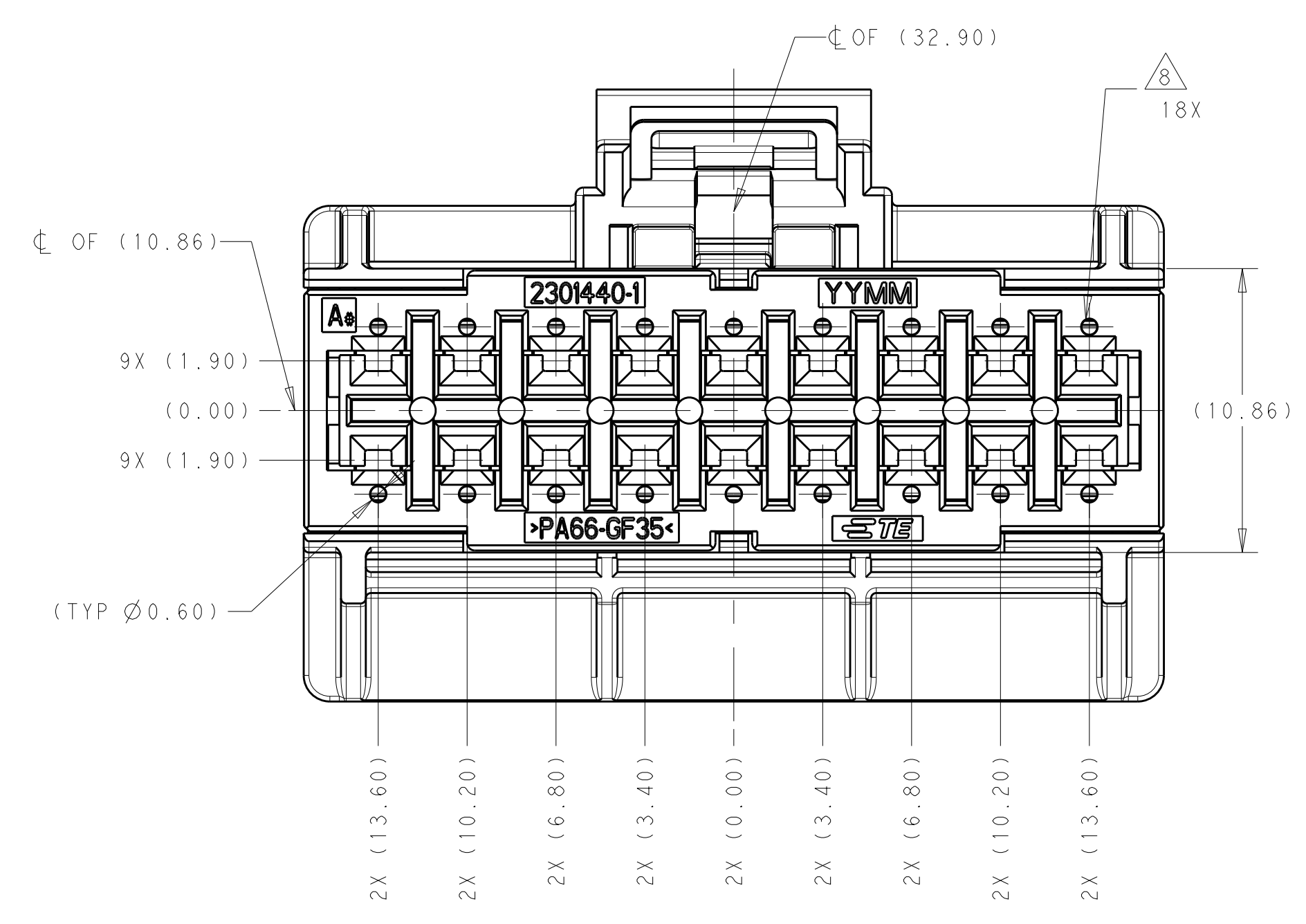
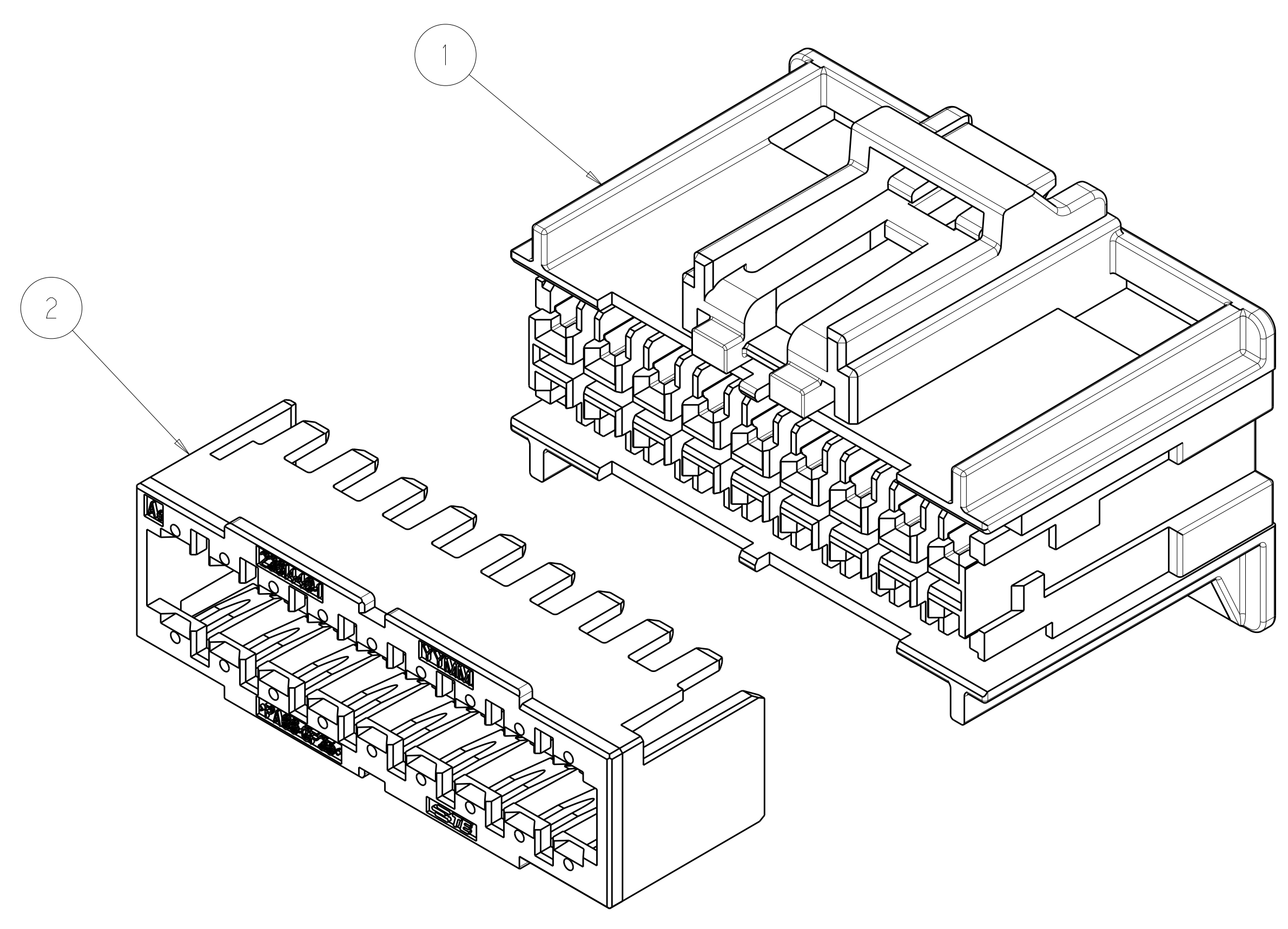

SECTION M-M

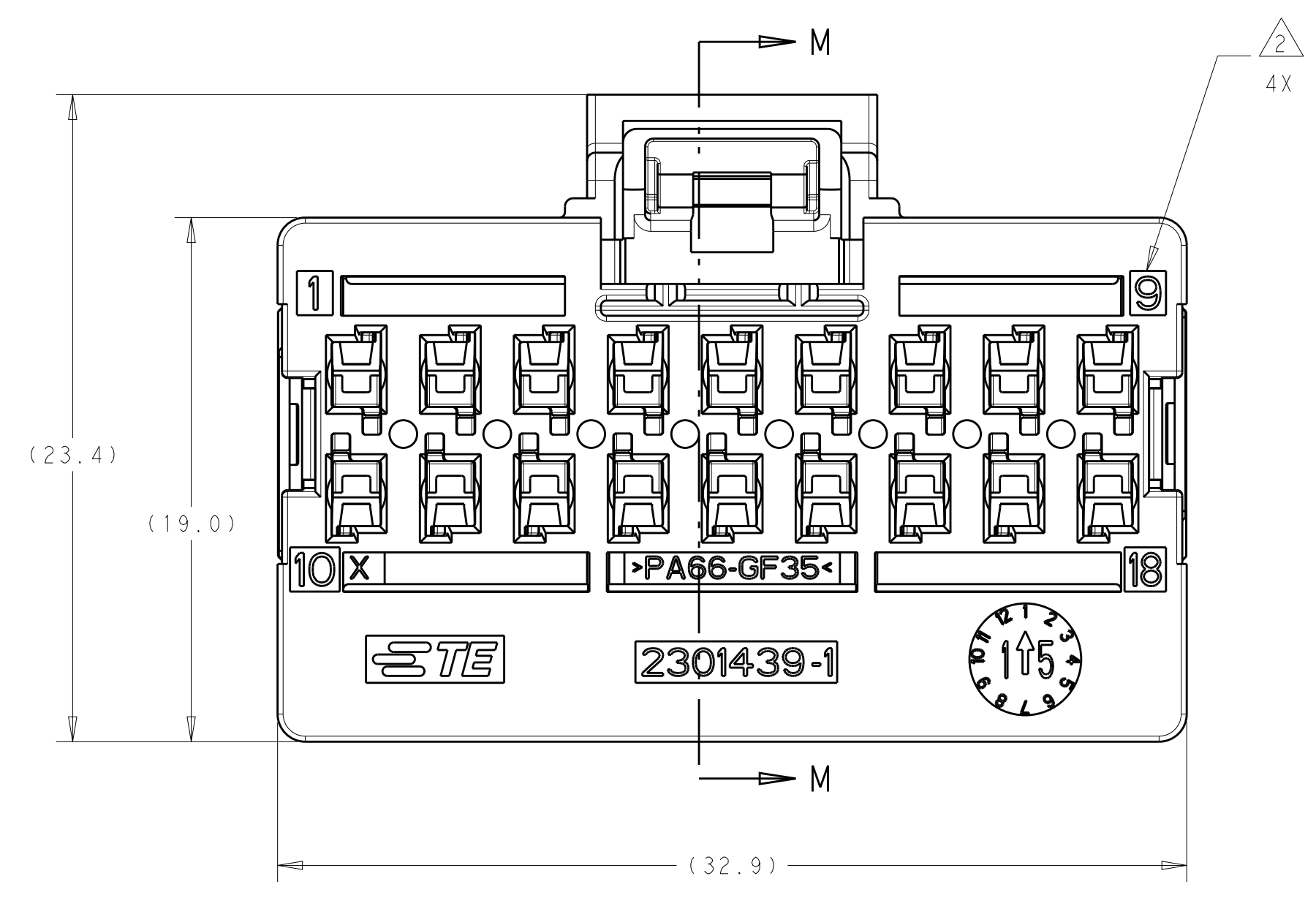
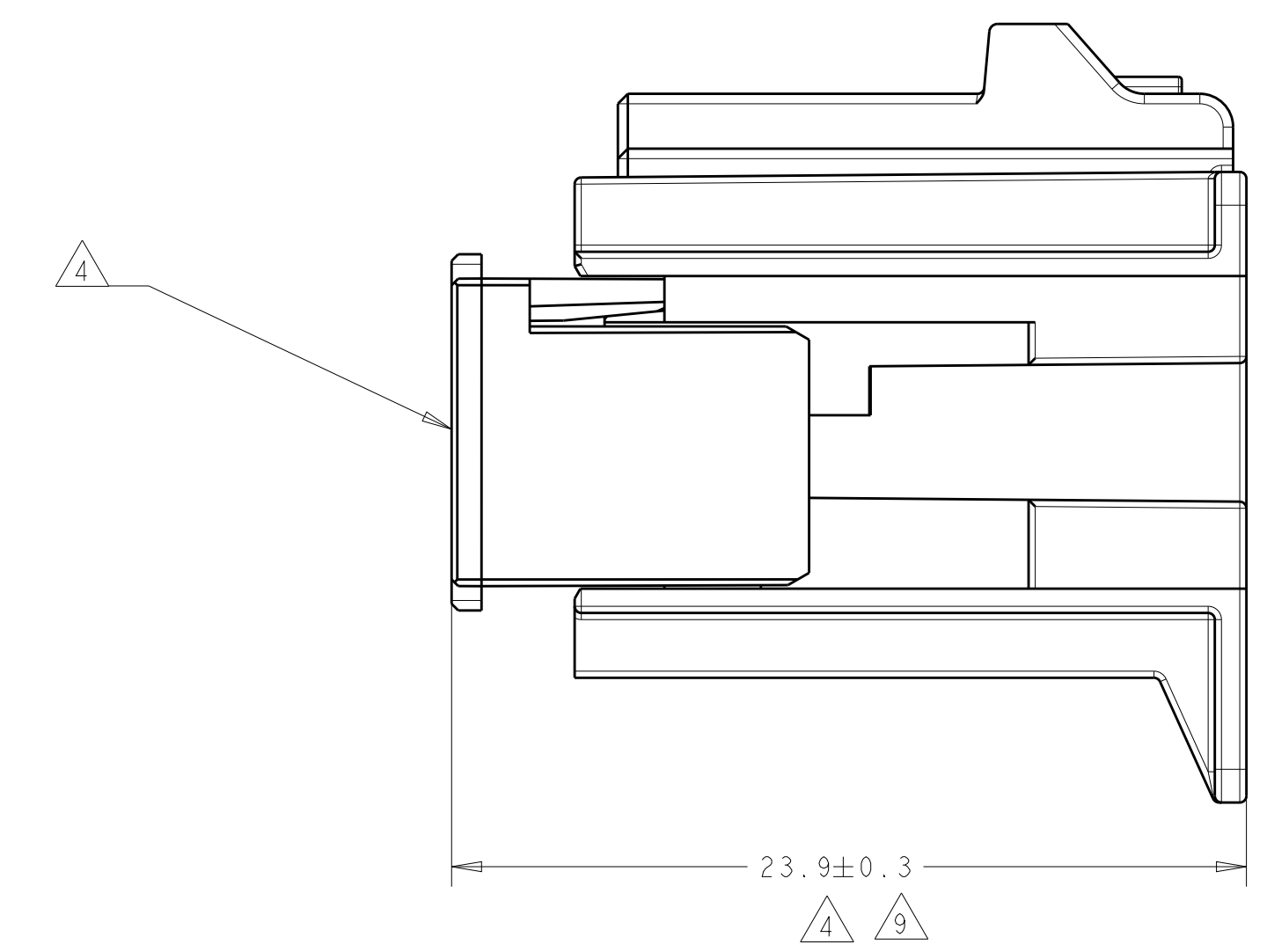

SCALE 4:1

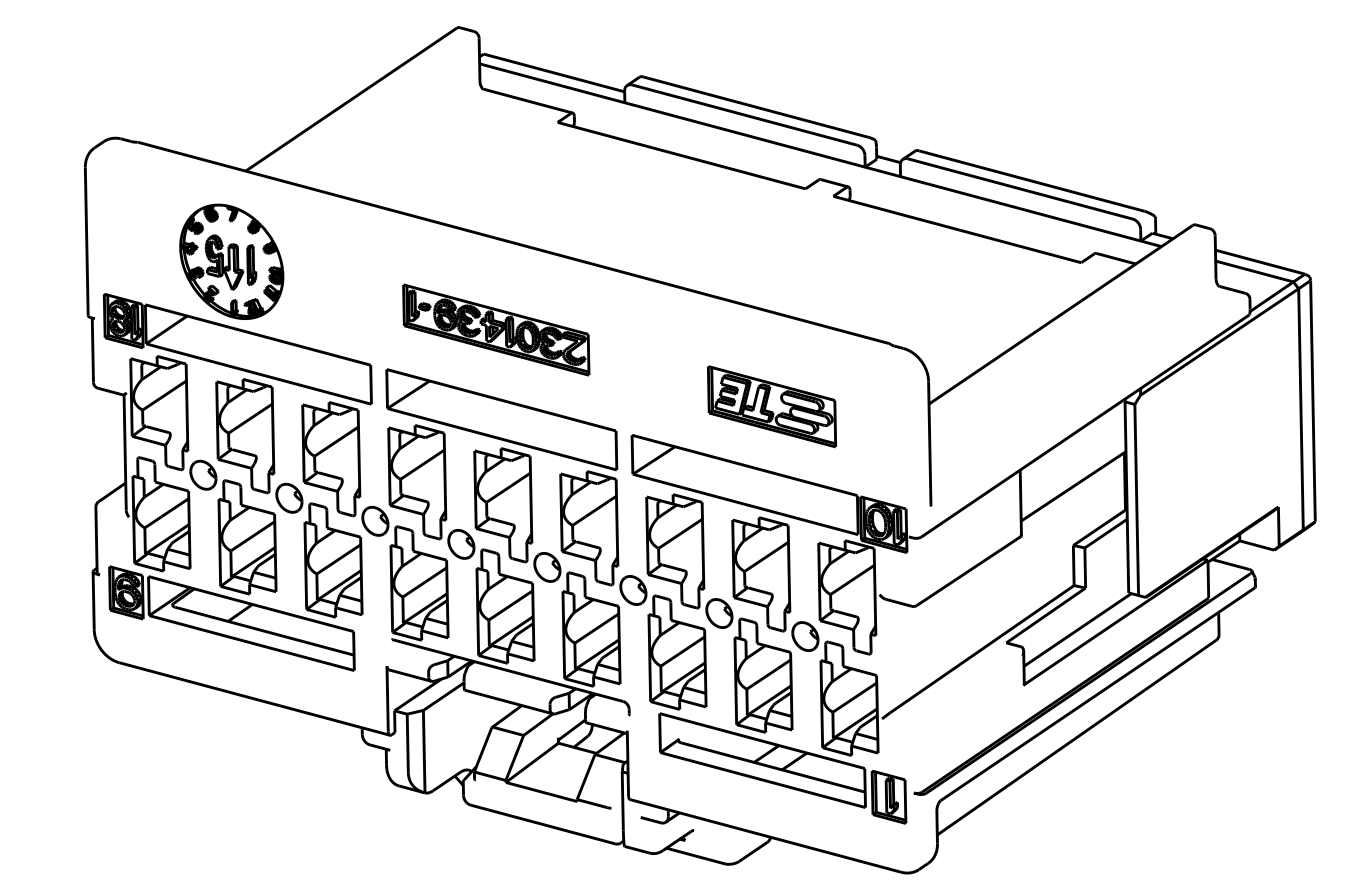
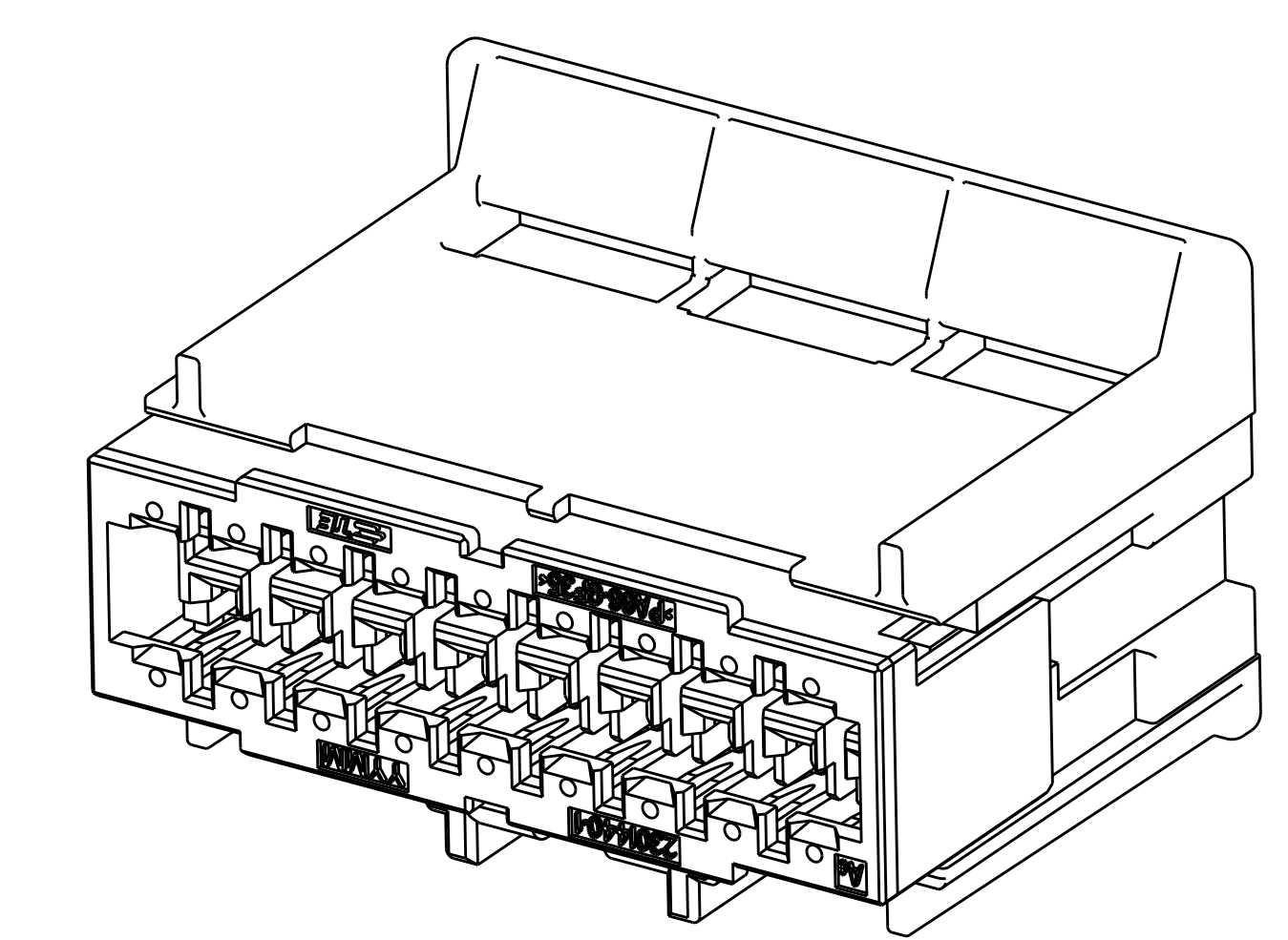

SCALE 4:1

- 2322290-1 SHOWN, SEE PART LIST FOR KEYING OPTIONS.
- CIRCUIT IDENTIFICATION
- MATING PART NUMBER: 2318053-X  
MATES TO INTERFACE DESIGNED PER 208-32024
- TPA SHOWN IN OPEN POSITION / SHIPPING POSITION.  
IF TPA IS CLOSED DURING SHIPPING, RESET TO OPEN POSITION
- TPA SHOWN IN CLOSED POSITION
- OPTIONAL CPA AVAILABLE 2290518-1
- APPLICABLE TERMINAL: GENERATION Y, 0.64 FEMALE  
TERMINAL PART NUMBERS (TIN PLATING):

2X 0.13mm <sup>2</sup> 0.35mm <sup>2</sup> (22AWG THIN WALL)	2098762-4
0.13mm <sup>2</sup> (26 AWG)	2098762-3
18 AWG	2098762-2
20-22AWG	2098762-1
WIRE SIZE	GENERAL SALES PART NO.

- LOCATION FOR CONTINUITY CHECK.
- DIMENSION AND/OR CHARACTERISTIC REQUIRES MEASUREMENT OR ATTRIBUTE DATA AND MUST BE REFLECTED IN CONTROL PLAN.

REV	DATE	BY	APPD	DESCRIPTION	ITEM NO.
1				NATURAL / OFF-WHITE	2
1				BLUE	1
-	1			GREEN	1
-	-	1		GRAY	1
-	-	-	1	TAN	1
2322290-4	2322290-3	2322290-2	2322290-1	COLOR	
				MATERIAL	
				DESCRIPTION	

QUANTITY REQUIRED FOR ASSEMBLY			
REV	DATE	BY	APPD
0	06 JUL 2017	Y. UMARJI	06 JUL 2017
1	07 JUL 2017	E. KHINNASARA	07 JUL 2017
2	08 JUL 2017	E. KHINNASARA	08 JUL 2017
3	08 JUL 2017	E. KHINNASARA	08 JUL 2017
4	08 JUL 2017	E. KHINNASARA	08 JUL 2017
5	08 JUL 2017	E. KHINNASARA	08 JUL 2017
6	08 JUL 2017	E. KHINNASARA	08 JUL 2017
7	08 JUL 2017	E. KHINNASARA	08 JUL 2017
8	08 JUL 2017	E. KHINNASARA	08 JUL 2017
9	08 JUL 2017	E. KHINNASARA	08 JUL 2017
10	08 JUL 2017	E. KHINNASARA	08 JUL 2017
11	08 JUL 2017	E. KHINNASARA	08 JUL 2017
12	08 JUL 2017	E. KHINNASARA	08 JUL 2017
13	08 JUL 2017	E. KHINNASARA	08 JUL 2017
14	08 JUL 2017	E. KHINNASARA	08 JUL 2017
15	08 JUL 2017	E. KHINNASARA	08 JUL 2017
16	08 JUL 2017	E. KHINNASARA	08 JUL 2017
17	08 JUL 2017	E. KHINNASARA	08 JUL 2017
18	08 JUL 2017	E. KHINNASARA	08 JUL 2017
19	08 JUL 2017	E. KHINNASARA	08 JUL 2017
20	08 JUL 2017	E. KHINNASARA	08 JUL 2017
21	08 JUL 2017	E. KHINNASARA	08 JUL 2017
22	08 JUL 2017	E. KHINNASARA	08 JUL 2017
23	08 JUL 2017	E. KHINNASARA	08 JUL 2017
24	08 JUL 2017	E. KHINNASARA	08 JUL 2017
25	08 JUL 2017	E. KHINNASARA	08 JUL 2017
26	08 JUL 2017	E. KHINNASARA	08 JUL 2017
27	08 JUL 2017	E. KHINNASARA	08 JUL 2017
28	08 JUL 2017	E. KHINNASARA	08 JUL 2017
29	08 JUL 2017	E. KHINNASARA	08 JUL 2017
30	08 JUL 2017	E. KHINNASARA	08 JUL 2017
31	08 JUL 2017	E. KHINNASARA	08 JUL 2017
32	08 JUL 2017	E. KHINNASARA	08 JUL 2017
33	08 JUL 2017	E. KHINNASARA	08 JUL 2017
34	08 JUL 2017	E. KHINNASARA	08 JUL 2017
35	08 JUL 2017	E. KHINNASARA	08 JUL 2017
36	08 JUL 2017	E. KHINNASARA	08 JUL 2017
37	08 JUL 2017	E. KHINNASARA	08 JUL 2017
38	08 JUL 2017	E. KHINNASARA	08 JUL 2017
39	08 JUL 2017	E. KHINNASARA	08 JUL 2017
40	08 JUL 2017	E. KHINNASARA	08 JUL 2017
41	08 JUL 2017	E. KHINNASARA	08 JUL 2017
42	08 JUL 2017	E. KHINNASARA	08 JUL 2017
43	08 JUL 2017	E. KHINNASARA	08 JUL 2017
44	08 JUL 2017	E. KHINNASARA	08 JUL 2017
45	08 JUL 2017	E. KHINNASARA	08 JUL 2017
46	08 JUL 2017	E. KHINNASARA	08 JUL 2017
47	08 JUL 2017	E. KHINNASARA	08 JUL 2017
48	08 JUL 2017	E. KHINNASARA	08 JUL 2017
49	08 JUL 2017	E. KHINNASARA	08 JUL 2017
50	08 JUL 2017	E. KHINNASARA	08 JUL 2017
51	08 JUL 2017	E. KHINNASARA	08 JUL 2017
52	08 JUL 2017	E. KHINNASARA	08 JUL 2017
53	08 JUL 2017	E. KHINNASARA	08 JUL 2017
54	08 JUL 2017	E. KHINNASARA	08 JUL 2017
55	08 JUL 2017	E. KHINNASARA	08 JUL 2017
56	08 JUL 2017	E. KHINNASARA	08 JUL 2017
57	08 JUL 2017	E. KHINNASARA	08 JUL 2017
58	08 JUL 2017	E. KHINNASARA	08 JUL 2017
59	08 JUL 2017	E. KHINNASARA	08 JUL 2017
60	08 JUL 2017	E. KHINNASARA	08 JUL 2017
61	08 JUL 2017	E. KHINNASARA	08 JUL 2017
62	08 JUL 2017	E. KHINNASARA	08 JUL 2017
63	08 JUL 2017	E. KHINNASARA	08 JUL 2017
64	08 JUL 2017	E. KHINNASARA	08 JUL 2017
65	08 JUL 2017	E. KHINNASARA	08 JUL 2017
66	08 JUL 2017	E. KHINNASARA	08 JUL 2017
67	08 JUL 2017	E. KHINNASARA	08 JUL 2017
68	08 JUL 2017	E. KHINNASARA	08 JUL 2017
69	08 JUL 2017	E. KHINNASARA	08 JUL 2017
70	08 JUL 2017	E. KHINNASARA	08 JUL 2017
71	08 JUL 2017	E. KHINNASARA	08 JUL 2017
72	08 JUL 2017	E. KHINNASARA	08 JUL 2017
73	08 JUL 2017	E. KHINNASARA	08 JUL 2017
74	08 JUL 2017	E. KHINNASARA	08 JUL 2017
75	08 JUL 2017	E. KHINNASARA	08 JUL 2017
76	08 JUL 2017	E. KHINNASARA	08 JUL 2017
77	08 JUL 2017	E. KHINNASARA	08 JUL 2017
78	08 JUL 2017	E. KHINNASARA	08 JUL 2017
79	08 JUL 2017	E. KHINNASARA	08 JUL 2017
80	08 JUL 2017	E. KHINNASARA	08 JUL 2017
81	08 JUL 2017	E. KHINNASARA	08 JUL 2017
82	08 JUL 2017	E. KHINNASARA	08 JUL 2017
83	08 JUL 2017	E. KHINNASARA	08 JUL 2017
84	08 JUL 2017	E. KHINNASARA	08 JUL 2017
85	08 JUL 2017	E. KHINNASARA	08 JUL 2017
86	08 JUL 2017	E. KHINNASARA	08 JUL 2017
87	08 JUL 2017	E. KHINNASARA	08 JUL 2017
88	08 JUL 2017	E. KHINNASARA	08 JUL 2017
89	08 JUL 2017	E. KHINNASARA	08 JUL 2017
90	08 JUL 2017	E. KHINNASARA	08 JUL 2017
91	08 JUL 2017	E. KHINNASARA	08 JUL 2017
92	08 JUL 2017	E. KHINNASARA	08 JUL 2017
93	08 JUL 2017	E. KHINNASARA	08 JUL 2017
94	08 JUL 2017	E. KHINNASARA	08 JUL 2017
95	08 JUL 2017	E. KHINNASARA	08 JUL 2017
96	08 JUL 2017	E. KHINNASARA	08 JUL 2017
97	08 JUL 2017	E. KHINNASARA	08 JUL 2017
98	08 JUL 2017	E. KHINNASARA	08 JUL 2017
99	08 JUL 2017	E. KHINNASARA	08 JUL 2017
100	08 JUL 2017	E. KHINNASARA	08 JUL 2017