

P	LTR	DESCRIPTION	DATE	DWN	APVD
A		RELEASE TO PRODUCTION	26APR2019	AY	PS
A1		REMOVED TOLERANCE FROM DIM F	17DEC2019	AY	PS

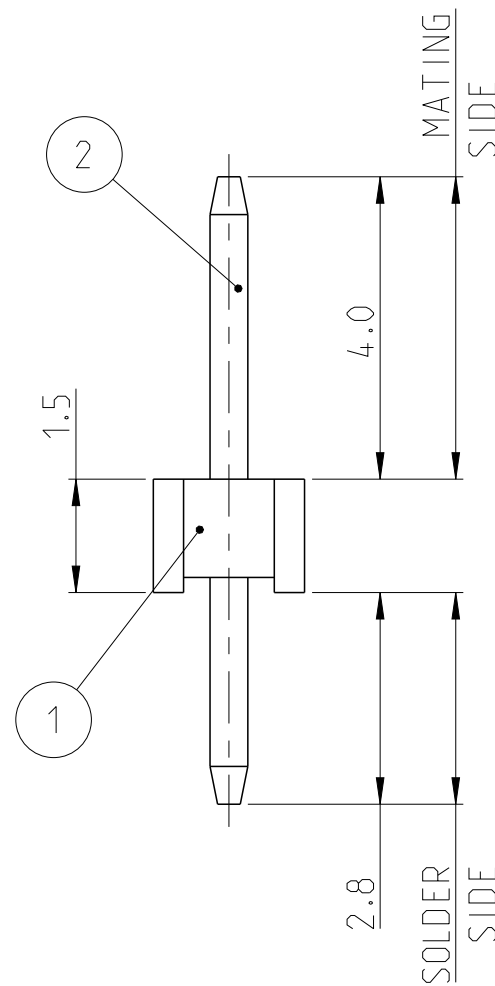

- NOTES:
- MATERIAL  
HOUSING : HIGH TEMPERATURE THERMOPLASTIC, UL94-V0; COLOR- BLACK  
POST : COPPER ALLOY  
FINISH : MIN. 2.0µm BRIGHT TIN OVER NICKEL UNDER PLATING.
  - PACKAGING: TUBE
  - TOLERANCE NOT CUMULATIVE.
  - CUTTING BURR MAX. 0.25 mm.

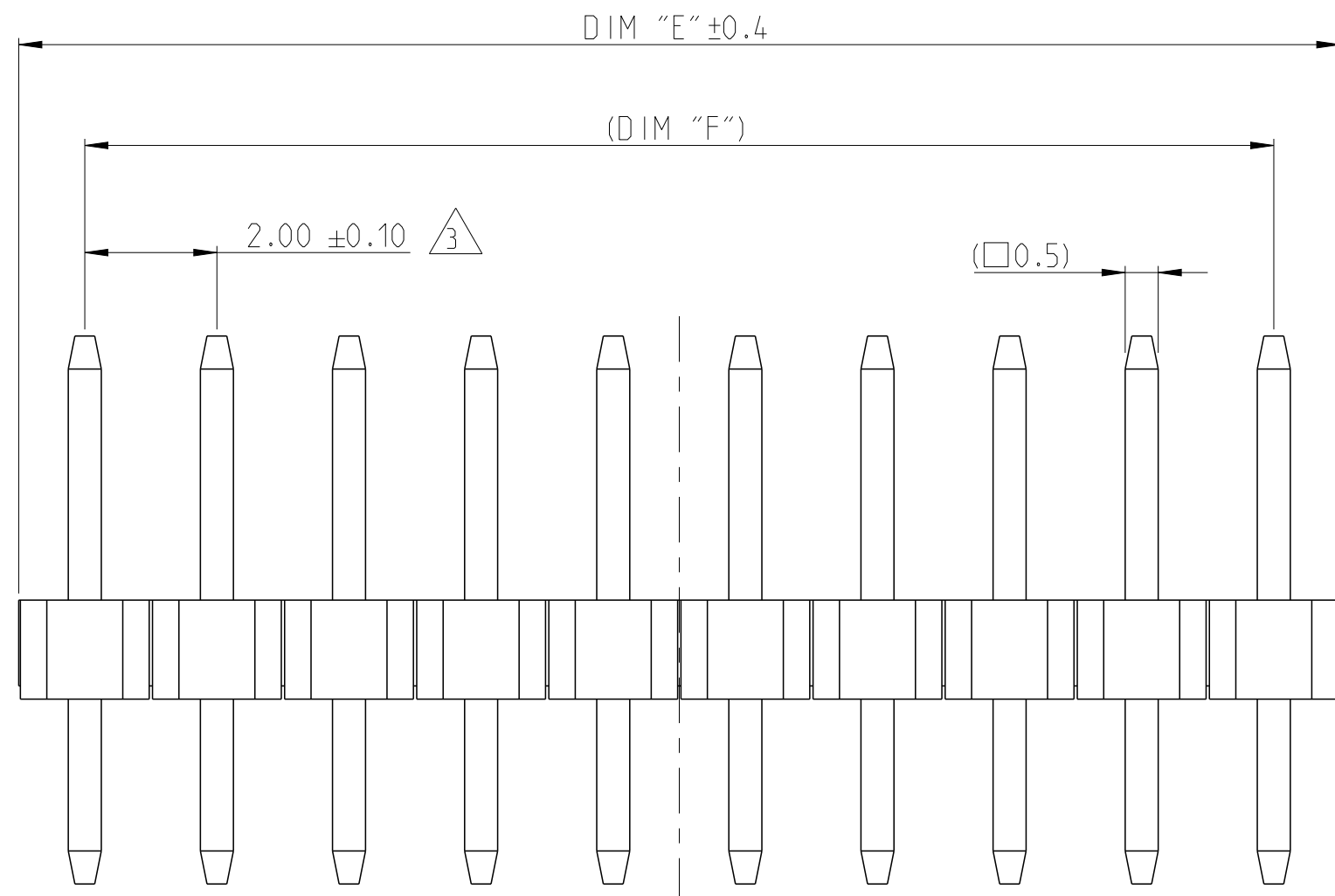
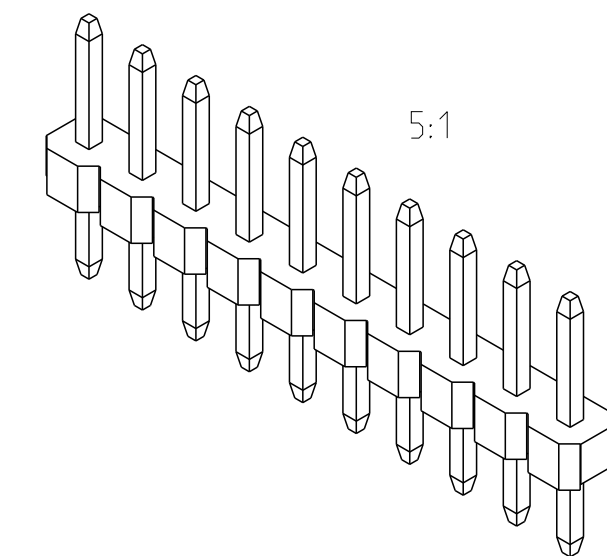
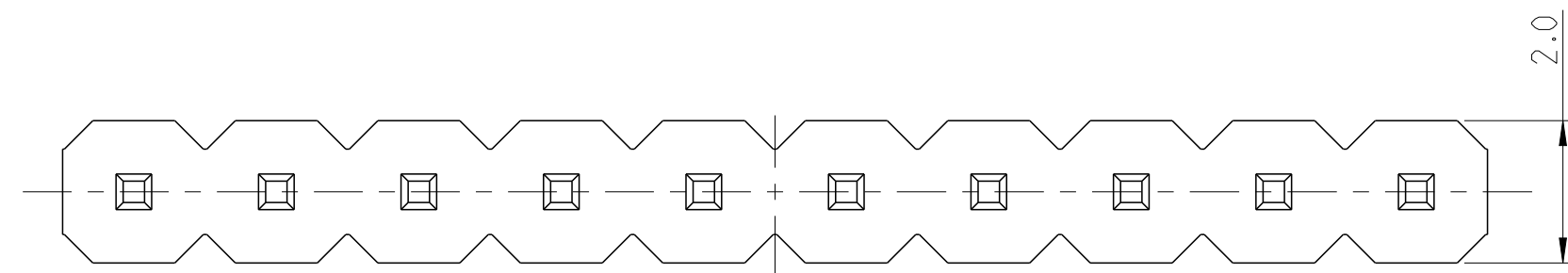

48.0	50.0	25	2-2355195-5
46.0	48.0	24	2-2355195-4
44.0	46.0	23	2-2355195-3
42.0	44.0	22	2-2355195-2
40.0	42.0	21	2-2355195-1
38.0	40.0	20	2-2355195-0
36.0	38.0	19	1-2355195-9
34.0	36.0	18	1-2355195-8
32.0	34.0	17	1-2355195-7
30.0	32.0	16	1-2355195-6
28.0	30.0	15	1-2355195-5
26.0	28.0	14	1-2355195-4
24.0	26.0	13	1-2355195-3
22.0	24.0	12	1-2355195-2
20.0	22.0	11	1-2355195-1
18.0	20.0	10	1-2355195-0
16.0	18.0	9	2355195-9
14.0	16.0	8	2355195-8
12.0	14.0	7	2355195-7
10.0	12.0	6	2355195-6
8.0	10.0	5	2355195-5
6.0	8.0	4	2355195-4
4.0	6.0	3	2355195-3
2.0	4.0	2	2355195-2
DIM "F"	DIM "E"	POS	TE PN

1-2355195-0 AS SHOWN

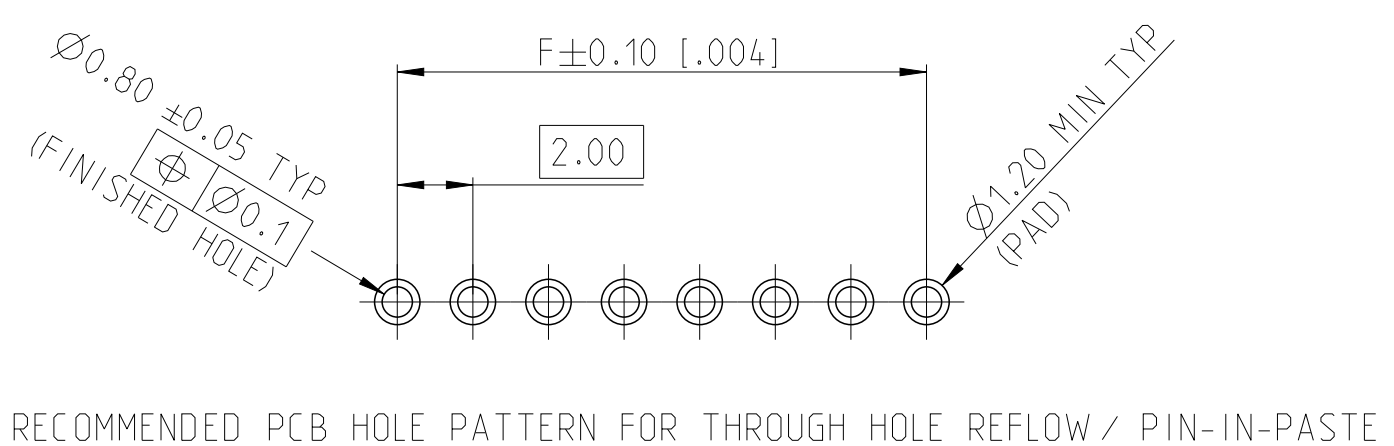
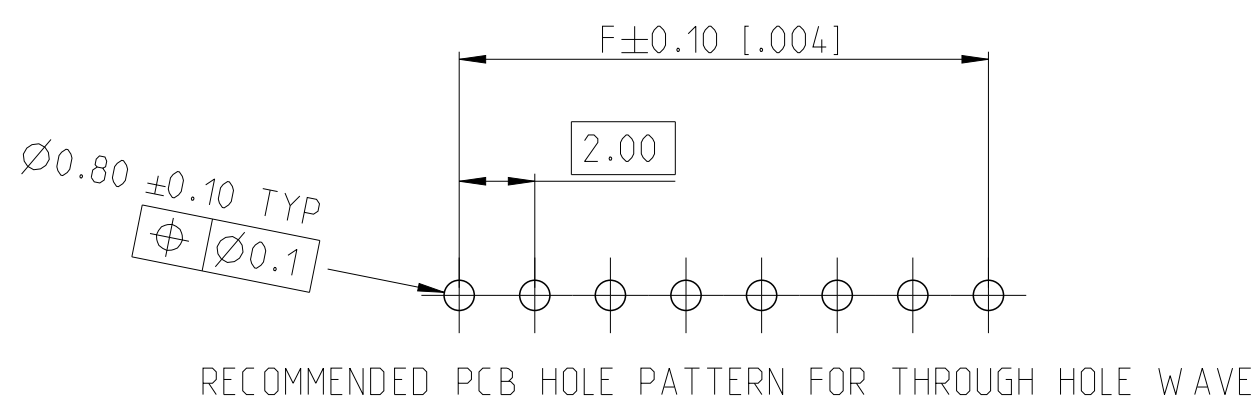

CONTACT PIN	2
HOUSING	1
DESCRIPTION	ITEM NO.

THIS DRAWING IS A CONTROLLED DOCUMENT.

DIMENSIONS: mm	TOLERANCES UNLESS OTHERWISE SPECIFIED:	DWN 09APR2019 RAGHAVENDRA.K	TE Connectivity NAME AMPMODU 2mm BREAKAWAY HEADER, SINGLE ROW, VERTICAL, Sn, TUBE
	0 PLC ±	CHK 14AUG2019 KARTHIK.JK	
	1 PLC ±0.2	APVD 16AUG2019 PRASHANTH	
	2 PLC ±0.15	PRODUCT SPEC 108-64040	
	3 PLC ±	APPLICATION SPEC 114-32259	SIZE A2
	4 PLC ±	WEIGHT -	CAGE CODE 00779
	ANGLES ±2°	CUSTOMER DRAWING	DRAWING NO. C-2355195
	FINISH	SCALE 10:1	SHEET 1 OF 1
			REV A1