

REVISIONS				
P.	LTN	DESCRIPTION	DATE	APVD
A		RELEASED PER ECO-20-008354	15JUN2020	BKW DH

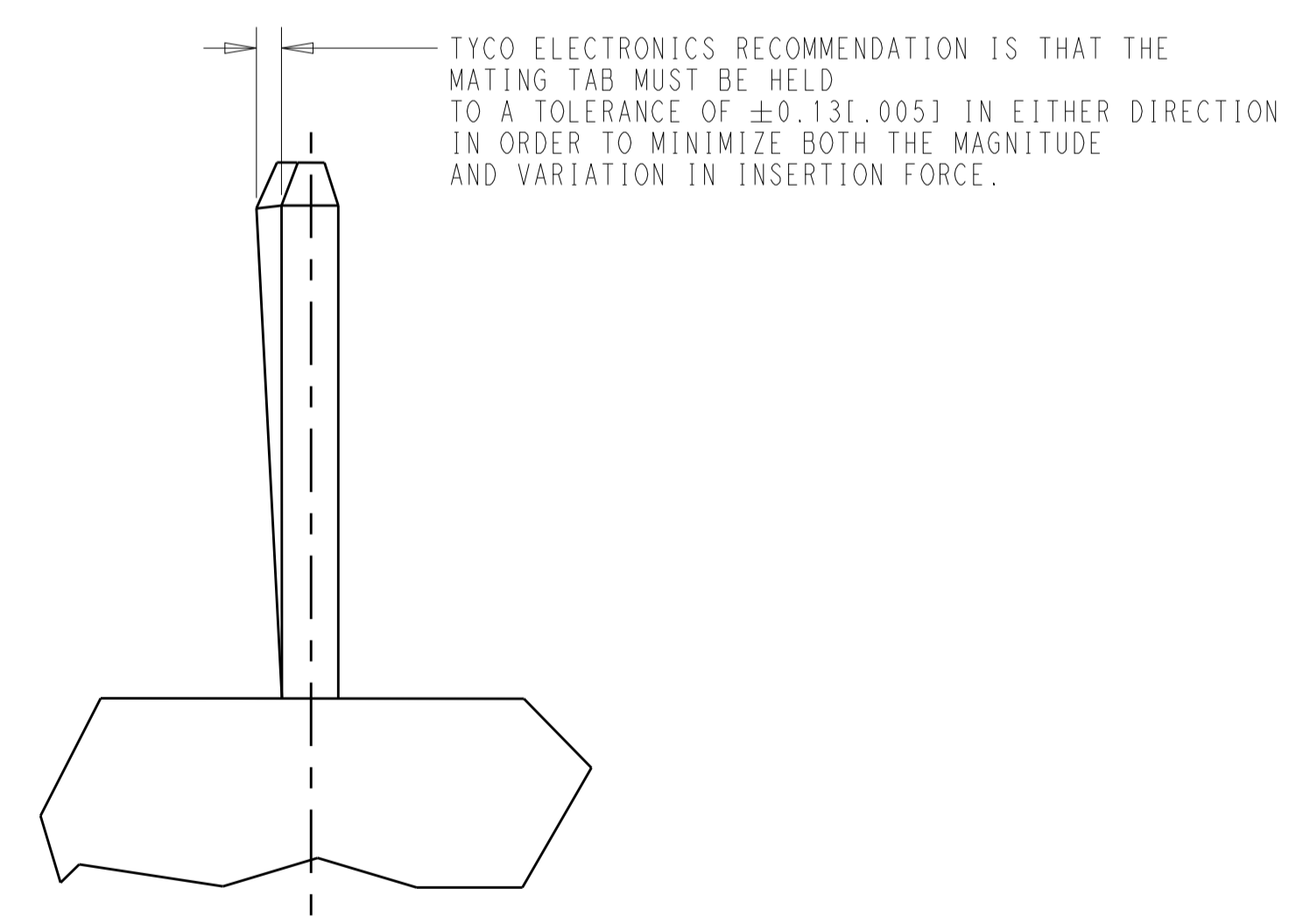
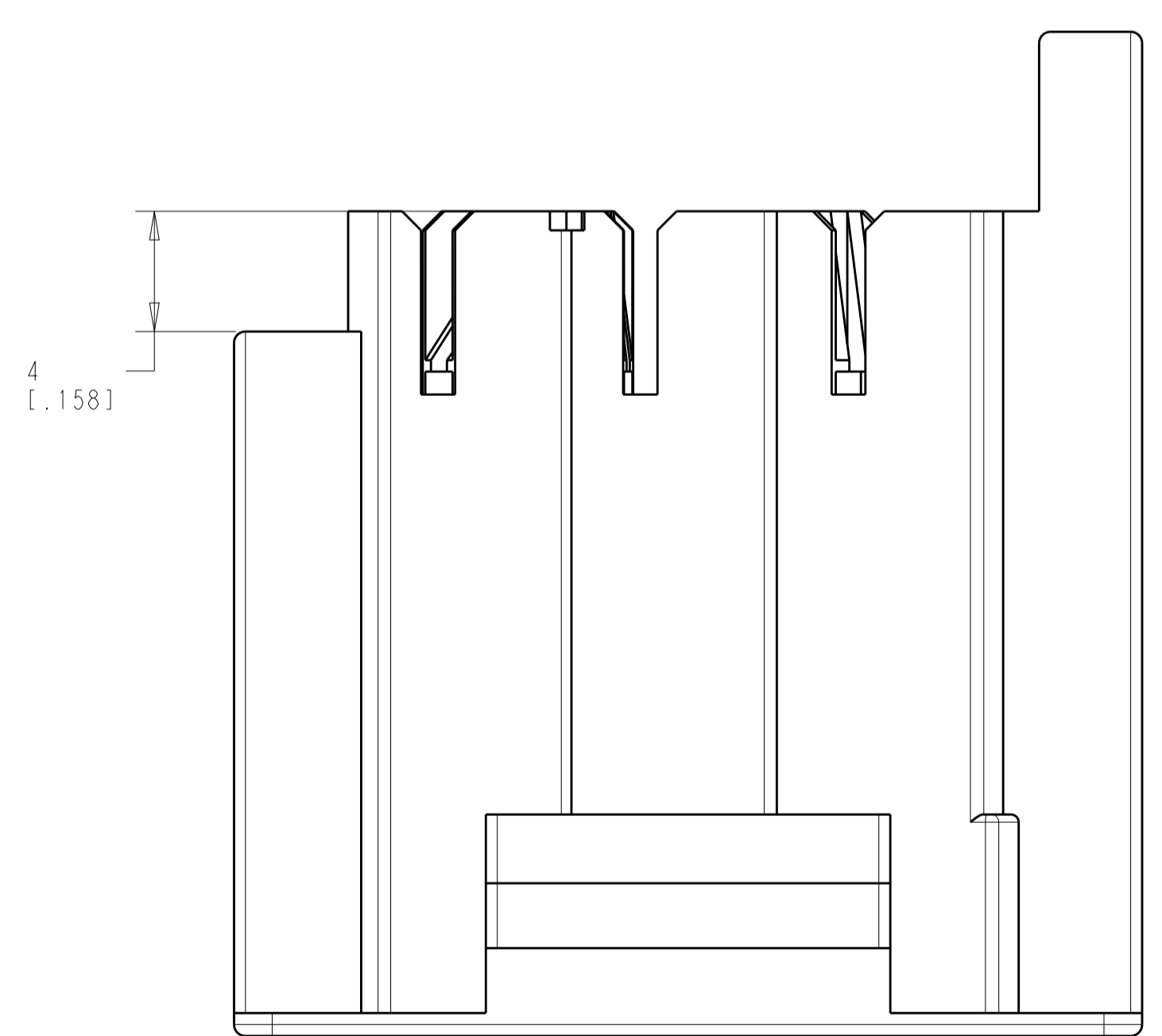
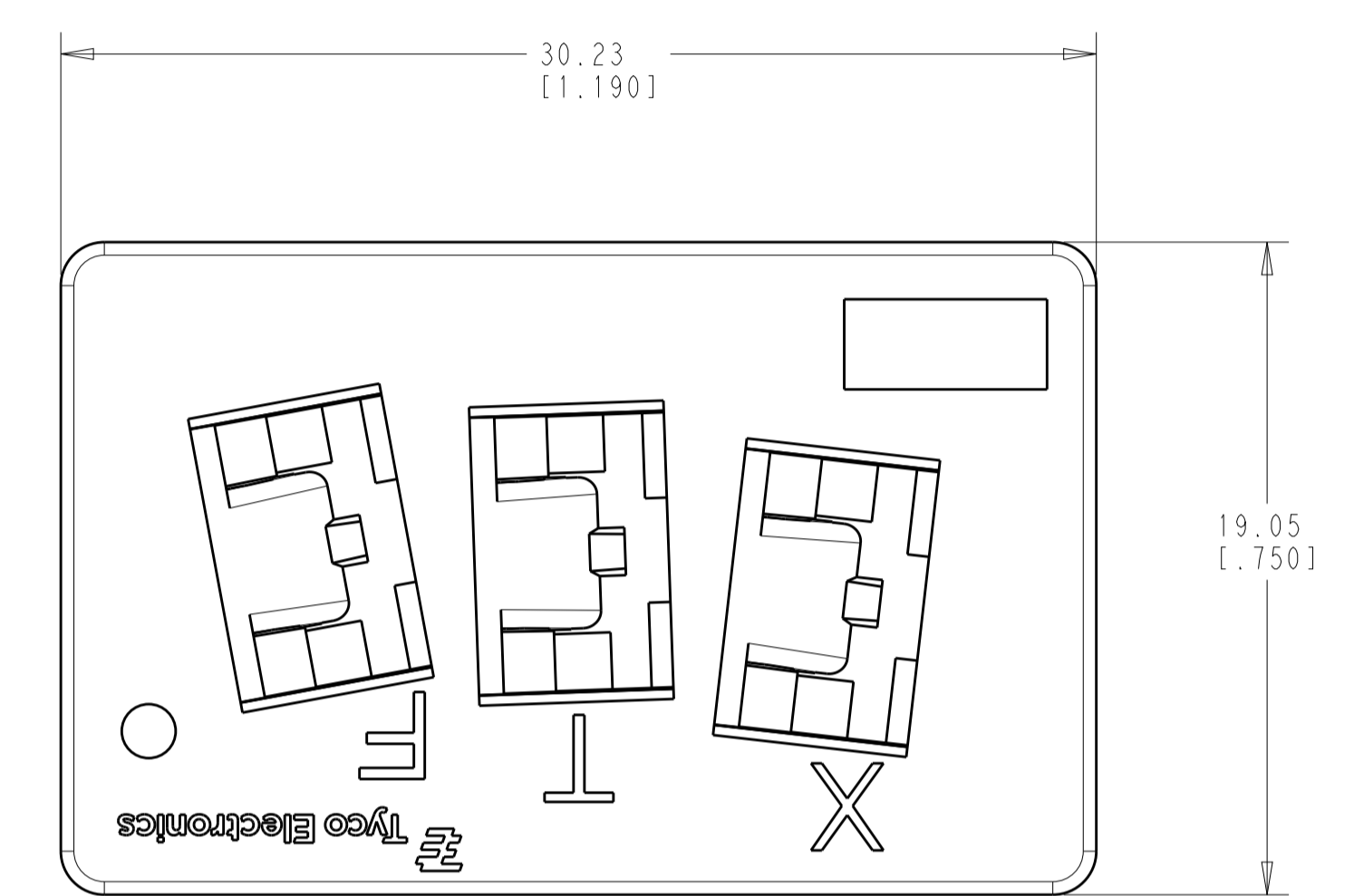
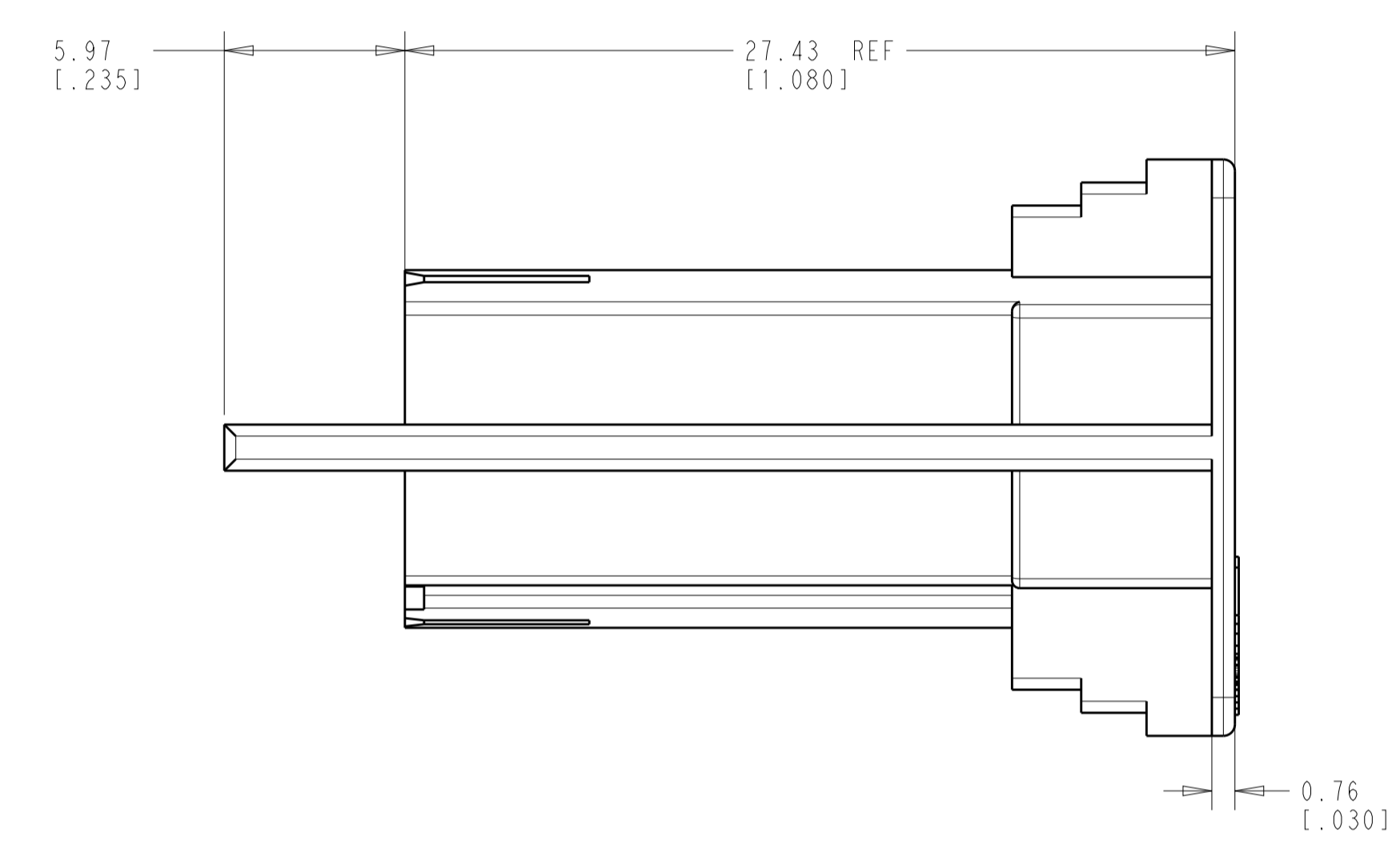
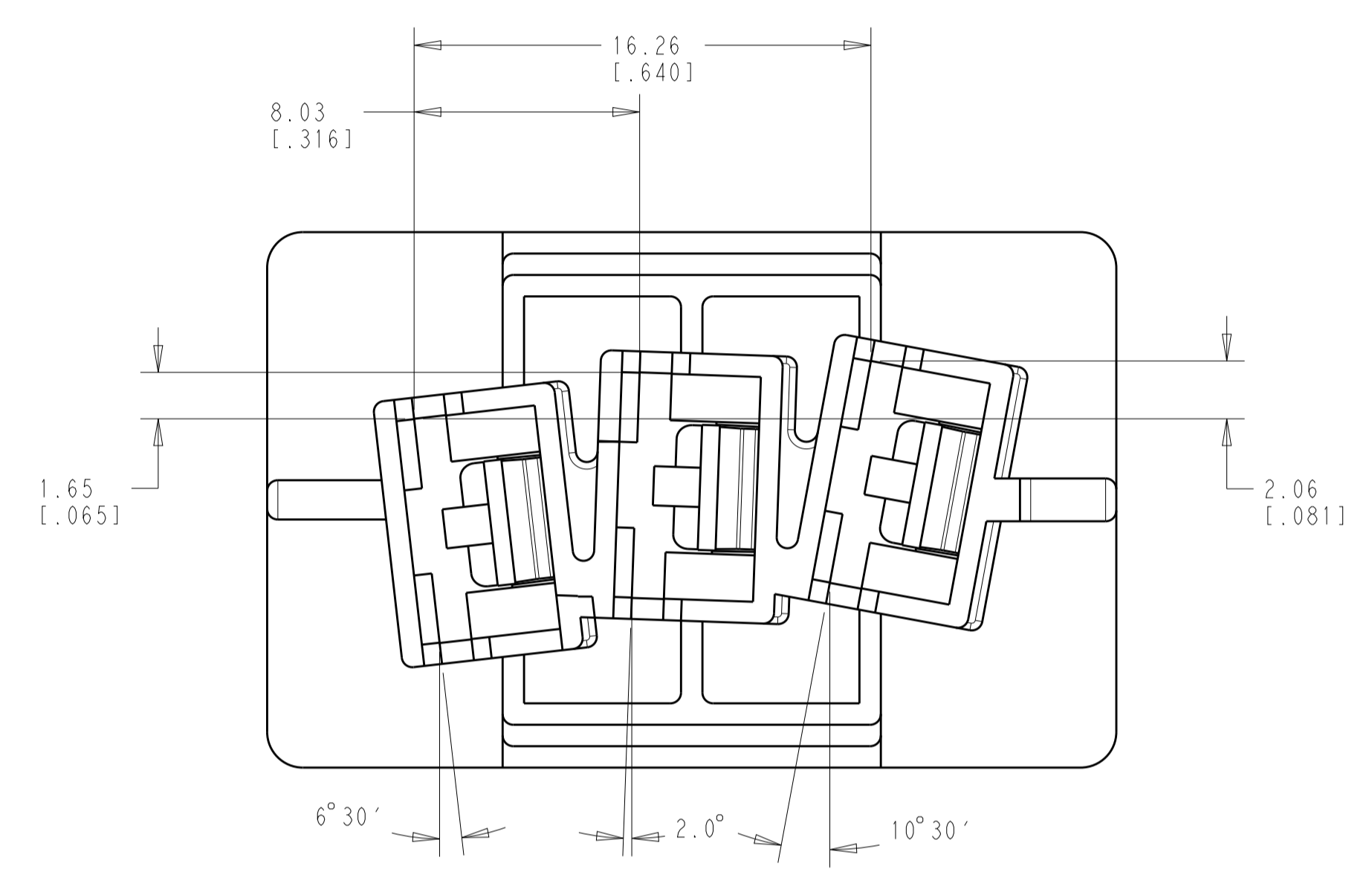

MATING TAB

NATURAL	66 NYLON, V0	2364485-1
COLOR	MATERIAL	PART NUMBER

THIS DRAWING IS A CONTROLLED DOCUMENT.		DWN: R. SMITH 18FEB2020	
DIMENSIONS: mm[inches]		CHK: D. HUMPHREY 29JAN2020	
TOLERANCES UNLESS OTHERWISE SPECIFIED:		APVD: D. HUMPHREY 29JAN2020	NAME: HOUSING, RECPT, FASTON, 6.35 [0.250] SERIES
0 PLC ±	1 PLC ±	PRODUCT SPEC	SIZE: A
2 PLC ±0.25(.010)	3 PLC ±	APPLICATION SPEC	CAGE CODE: 00779
4 PLC ±	ANGLES ±1°	FINISH: NATURAL	DRAWING NO: 2364485
MATERIAL: SEE TABLE	FINISH: NATURAL	WEIGHT: -	RESTRICTED TO: -
CUSTOMER DRAWING		SCALE: 5:1	SHEET 1 OF 1 REV A