

REVISIONS					
P	LTR	DESCRIPTION	DATE	DWN	APVD
A		REVISED PER ECN-21-102367	15APR2021	WH	DZ
A1		REVISED PER ECN-21-105092	20MAY2021	WH	DZ
B		REVISED PER ECN-21-107141	21JUL2021	WH	DZ
B2		REVISED PER ECR-21-115397	16NOV2021	SK	DZ

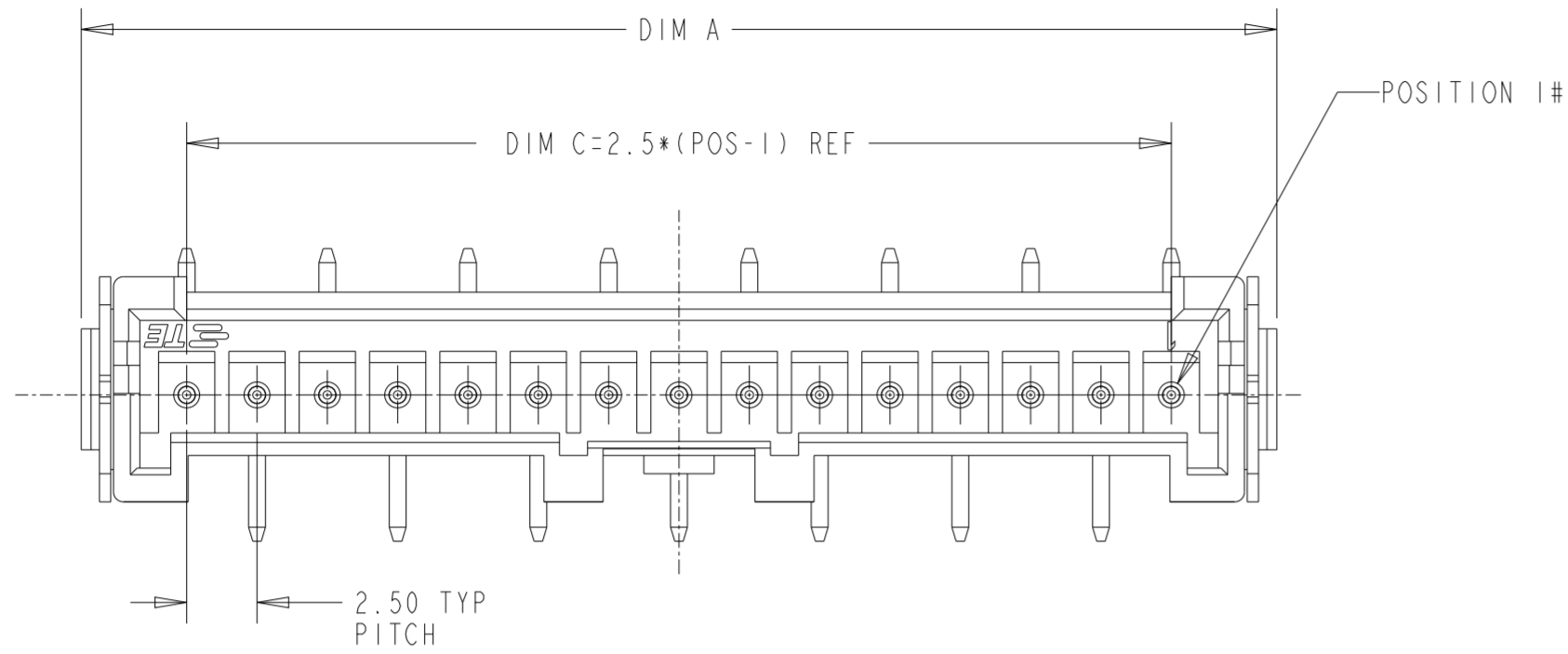

- 1 MATERIAL:
HOUSING: HIGH TEMPERATURE NYLON, UL94V-0, COLOR: NATURAL
PIN CONTACT: COPPER ALLOY, 2.0µm MIN TIN OVER 1.0µm MIN NICKEL OVERALL
SOLDER PEG: STEEL, 2.0µm MIN TIN OVER 1.0µm MIN NICKEL OVERALL
- 2 COLOR STRIP IS DEFINED AS SHOWN, AND THE DETAIL PART SHOWN AS TABLE
PART COLOR VARIES IN TINT AND MAY APPEAR UNEVENLY MIXED
COLOR FLASH OR COLOR RUNOUT ALLOWED.
- 3. SEE SHEET 3 FOR KEYING AND POLARIZATION
- 4. RECOMMENDED MATING PART:
NATURAL VERSION: 2312294-[] OR []-1744417-[]
COLORED VERSION: []-2338183-[]
- 5. PACKAGING: TAPE REEL, SEE THE DETIAL AS SHEET 4
- 6. PER IEC 60335-1 SECT. 30, GWEPT 750°C, NO FLAME OR $T_e-T_i < 2S$

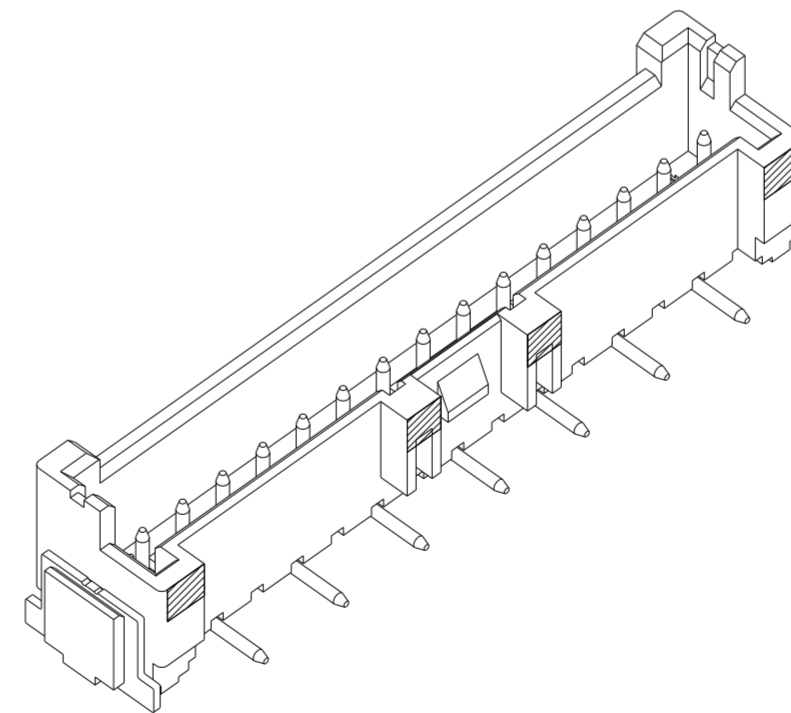
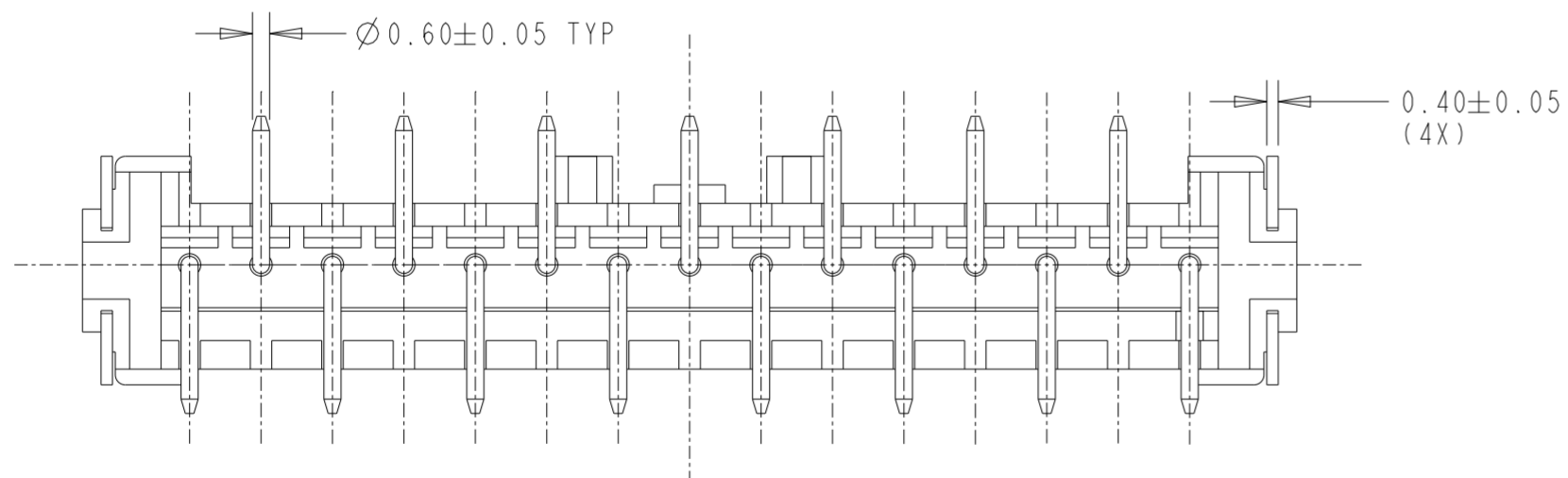
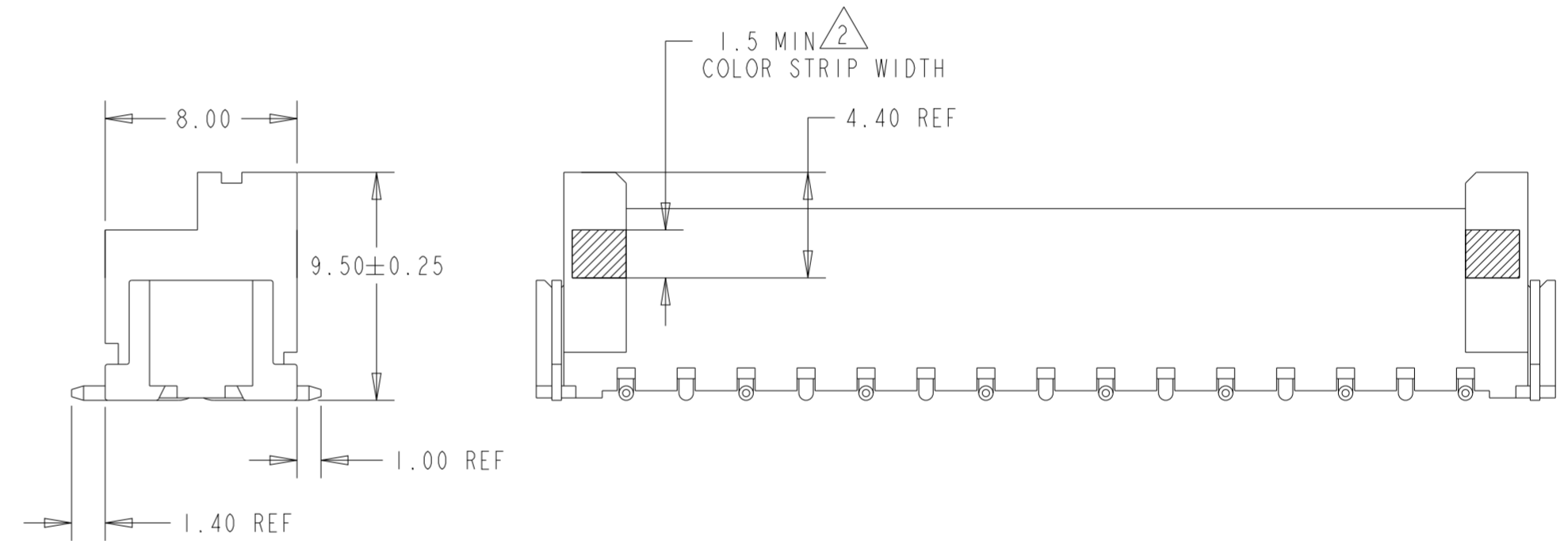
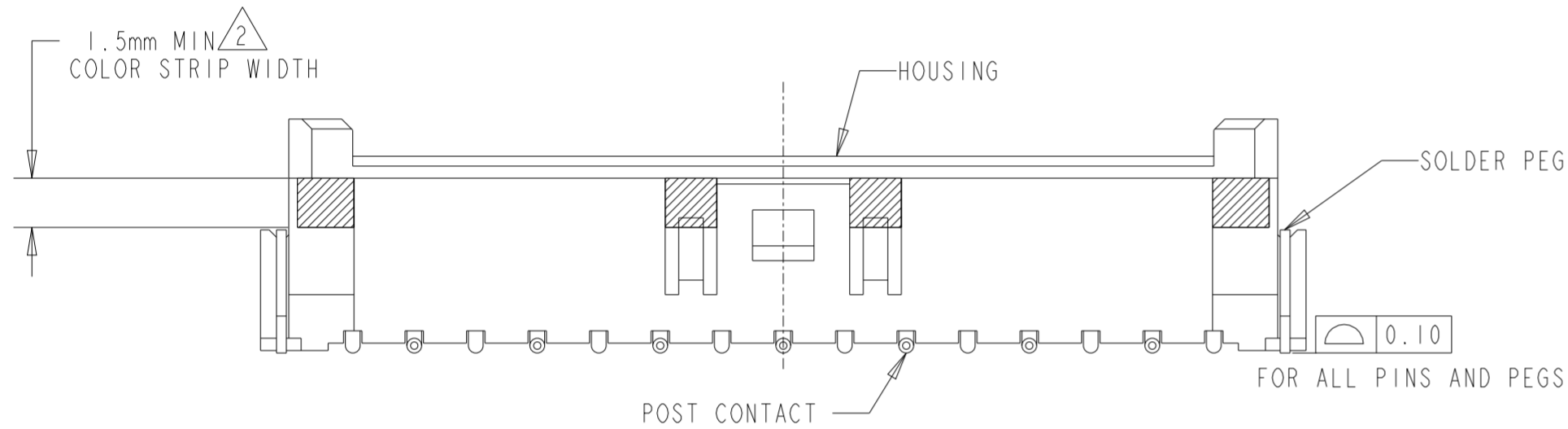

THIS DRAWING IS A CONTROLLED DOCUMENT.		DWN W. HUO	15APR2020	TE Connectivity	
DIMENSIONS: mm		CHK D. ZHANG	17APR2020		
TOLERANCES UNLESS OTHERWISE SPECIFIED:		APVD D. ZHANG	17APR2020	NAME HEADER ASSEMBLY, GWT, SMT TYPE, VERTICAL, SINGLE ROW, EP2.5	
0 PLC ± 1 PLC ± 2 PLC ±0.25 3 PLC ± 4 PLC ± ANGLES ±3° FINISH		PRODUCT SPEC 108-2418		SIZE A2	
MATERIAL		APPLICATION SPEC 114-13315		CAGE CODE 00779	DRAWING NO C-2365497
		WEIGHT -		RESTRICTED TO -	SCALE N/A
		CUSTOMER DRAWING		SHEET 1	OF 4
				REV B2	

REVISIONS

P	LTR	DESCRIPTION	DATE	DWN	APVD
-	-	SEE SHEET 1	-	-	-

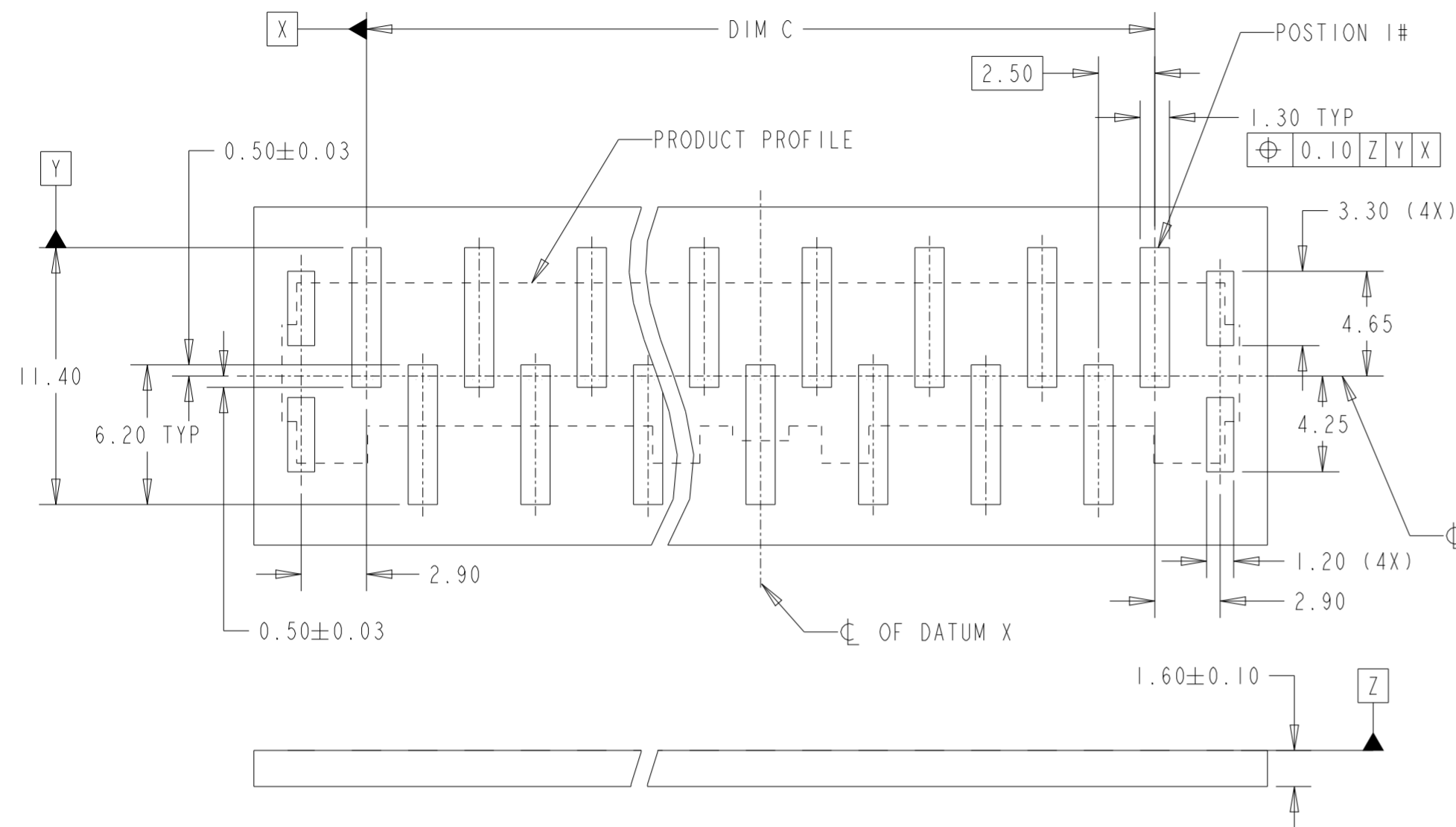

RECOMMENDED PCB LAYOUT OF ODD POSITION[3,5,7,9,11,13 AND 15]
TOLERANCE: ±0.05

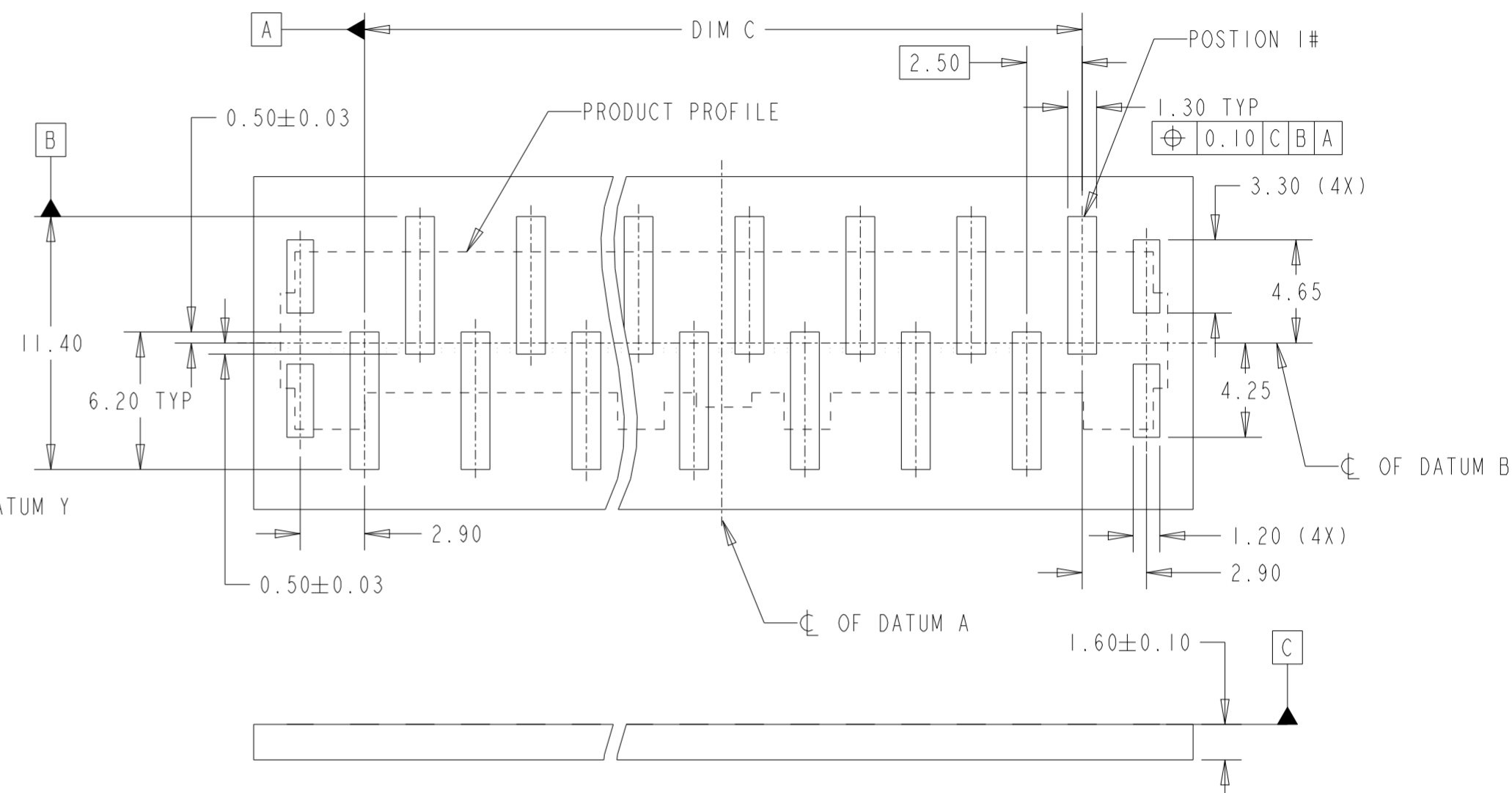

RECOMMENDED PCB LAYOUT OF EVEN POSITION[2,4,6,8,10,12 AND 14]
TOLERANCE: ±0.05

35.00	42.50	15	1-2365497-5	3-2365497-5	5-2365497-5	7-2365497-5	9-2365497-5	7-2365497-7
32.50	40.00	14	1-2365497-4	3-2365497-4	5-2365497-4	7-2365497-4	9-2365497-4	7-2365497-6
30.00	37.50	13	1-2365497-3	3-2365497-3	5-2365497-3	7-2365497-3	9-2365497-3	5-2365497-9
27.50	35.00	12	1-2365497-2	3-2365497-2	5-2365497-2	7-2365497-2	9-2365497-2	5-2365497-8
25.00	32.50	11	1-2365497-1	3-2365497-1	5-2365497-1	7-2365497-1	9-2365497-1	5-2365497-7
22.50	30.00	10	1-2365497-0	3-2365497-0	5-2365497-0	7-2365497-0	9-2365497-0	5-2365497-6
20.00	27.50	9	2365497-9	2-2365497-9	4-2365497-9	6-2365497-9	8-2365497-9	3-2365497-9
17.50	25.00	8	2365497-8	2-2365497-8	4-2365497-8	6-2365497-8	8-2365497-8	3-2365497-8
15.00	22.50	7	2365497-7	2-2365497-7	4-2365497-7	6-2365497-7	8-2365497-7	3-2365497-7
12.50	20.00	6	2365497-6	2-2365497-6	4-2365497-6	6-2365497-6	8-2365497-6	3-2365497-6
10.00	17.50	5	2365497-5	2-2365497-5	4-2365497-5	6-2365497-5	8-2365497-5	1-2365497-9
7.50	15.00	4	2365497-4	2-2365497-4	4-2365497-4	6-2365497-4	8-2365497-4	1-2365497-8
5.00	12.50	3	2365497-3	2-2365497-3	4-2365497-3	6-2365497-3	8-2365497-3	1-2365497-7
2.50	10.00	2	2365497-2	2-2365497-2	4-2365497-2	6-2365497-2	8-2365497-2	1-2365497-6
DIM.C	DIM.A	POS.	NATURAL	△ RED	△ BLUE	△ BLACK	△ YELLOW	△ GREEN
ASSEMBLY PART NO. (COLOR STRIP TYPE)								

THIS DRAWING IS A CONTROLLED DOCUMENT.

DIMENSIONS:	TOLERANCES UNLESS OTHERWISE SPECIFIED:	DWN	W. HUO	15APR2020
mm	0 PLC ±	CHK	D. ZHANG	17APR2020
	1 PLC ±	APVD	D. ZHANG	17APR2020
	2 PLC ±0.25	PRODUCT SPEC	108-2418	
	3 PLC ±	APPLICATION SPEC	114-13315	
	4 PLC ±	WEIGHT	-	
	ANGLES ±3°	CUSTOMER DRAWING		
	FINISH	SCALE	N/A	SHEET 2 OF 4

STE TE Connectivity

NAME: HEADER ASSEMBLY, GWT, SMT TYPE, VERTICAL, SINGLE ROW, EP2.5

SIZE: A2 CAGE CODE: 00779 DRAWING NO: C-2365497 RESTRICTED TO: -

REV: B2

REVISIONS				
P	LTR	DESCRIPTION	DATE	APVD
-	-	SEE SHEET 1	-	-

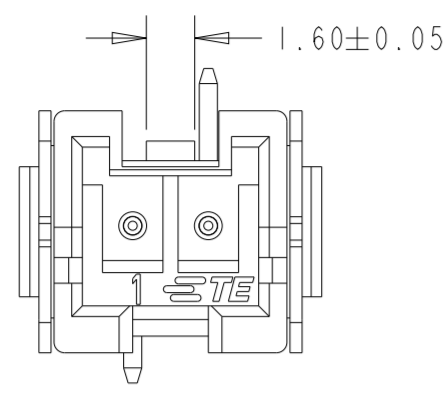

2 POSITION

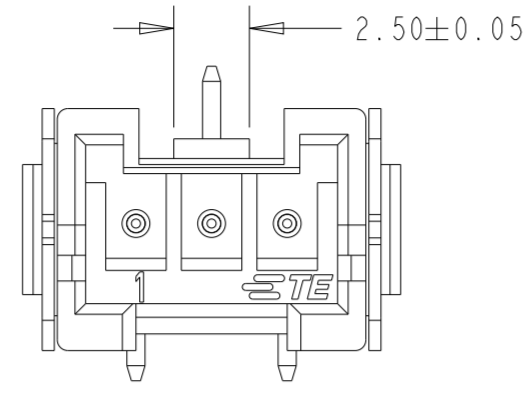

3 POSITION

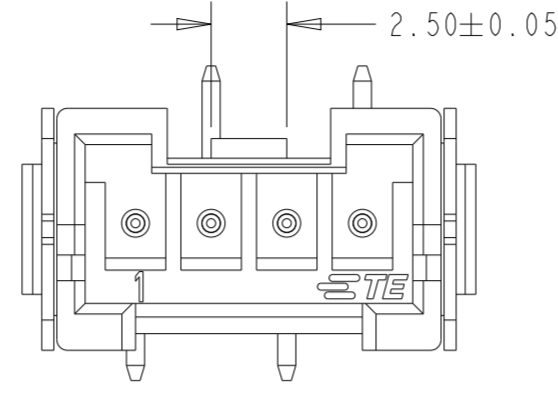

4 POSITION

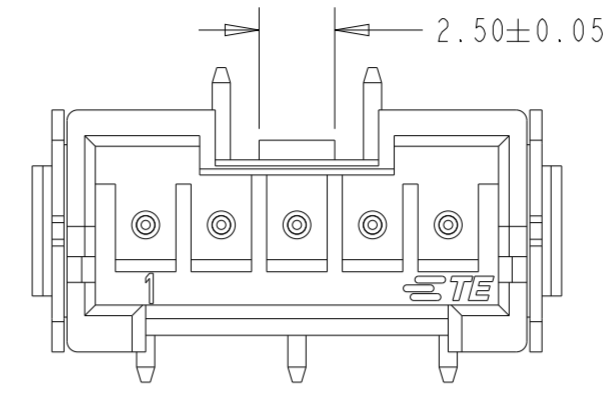

5 POSITION

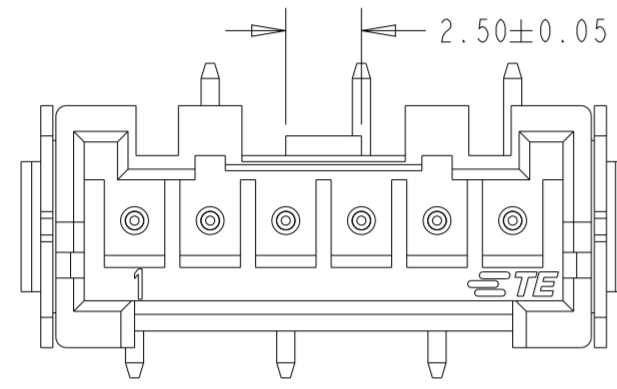

6 POSITION

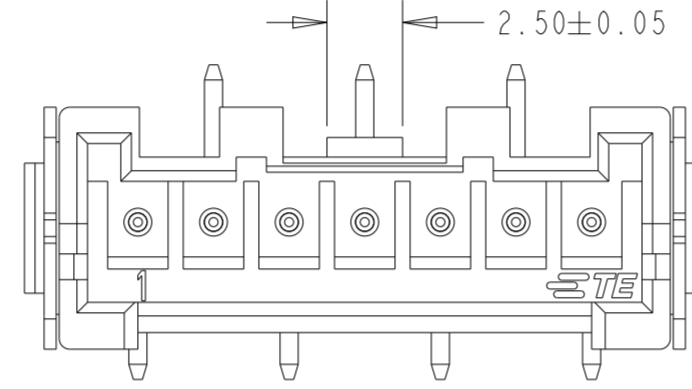

7 POSITION

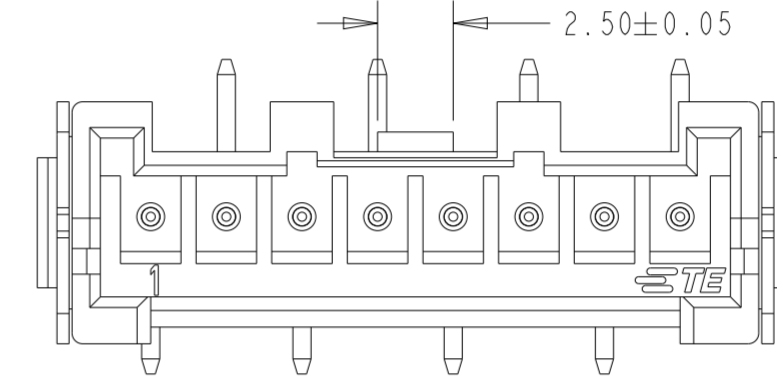

8 POSITION

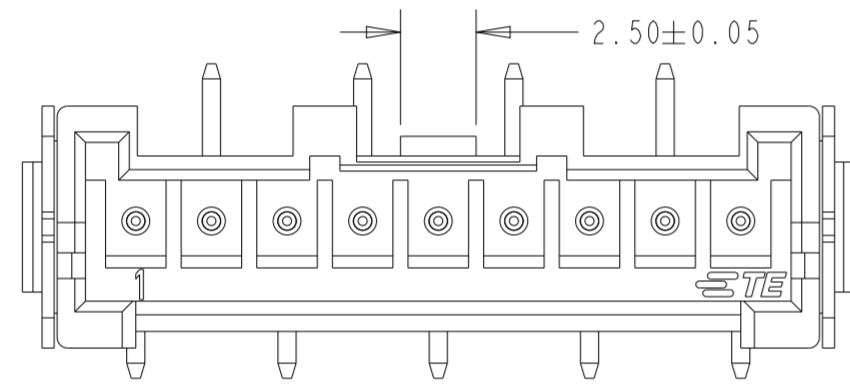

9 POSITION

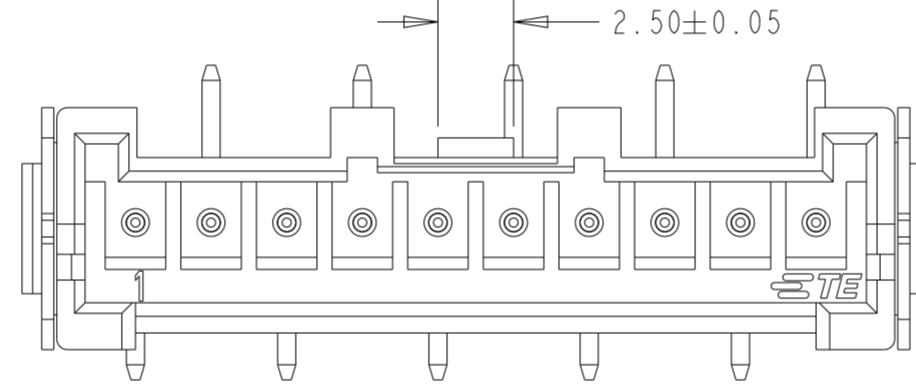

10 POSITION

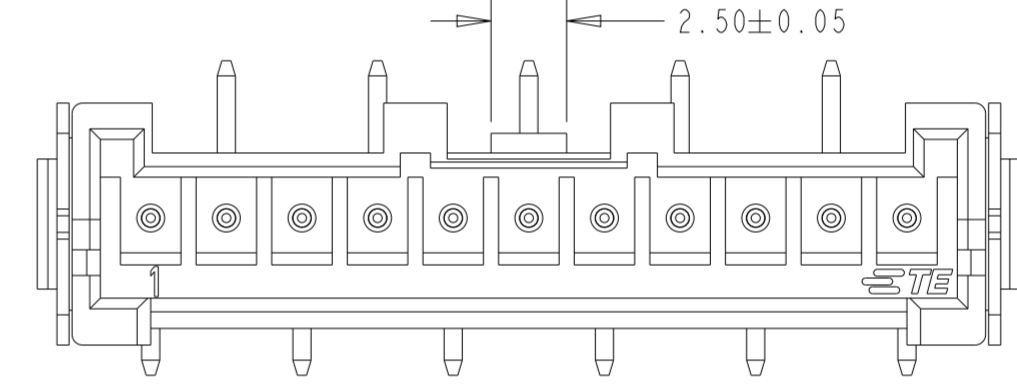

11 POSITION

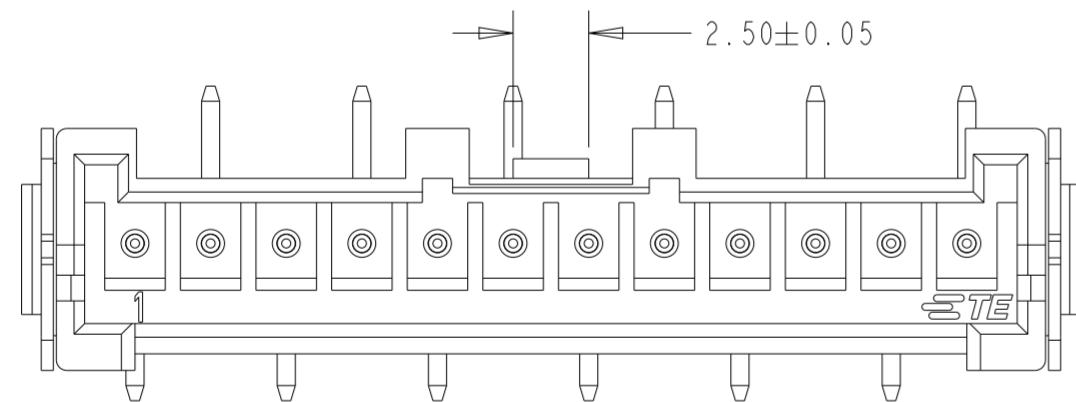

12 POSITION

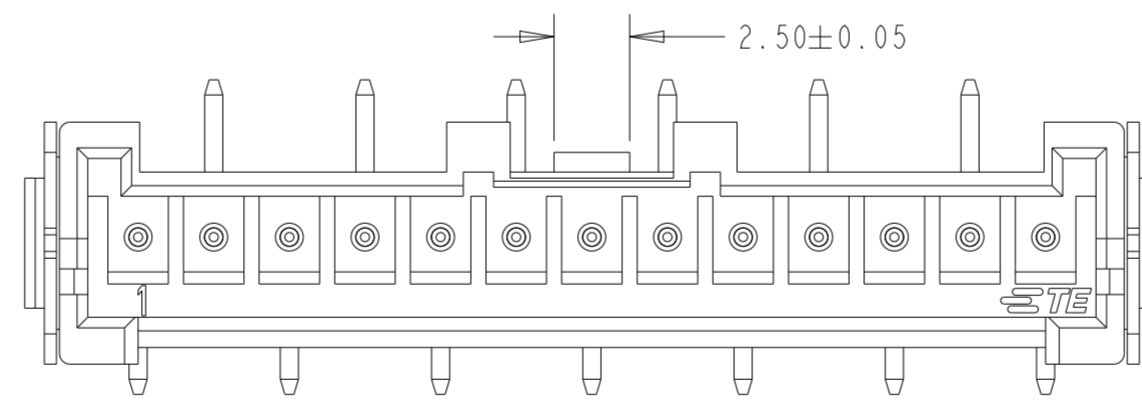

13 POSITION

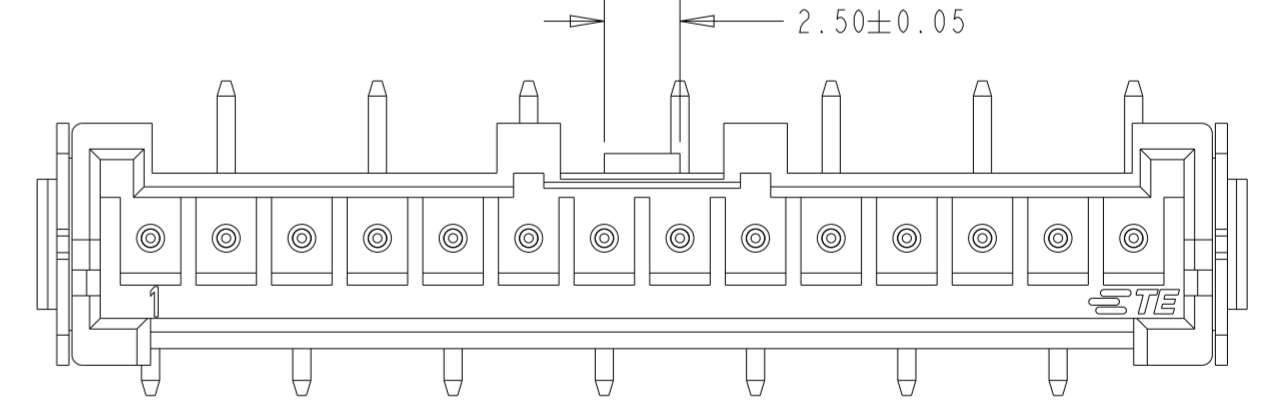

14 POSITION

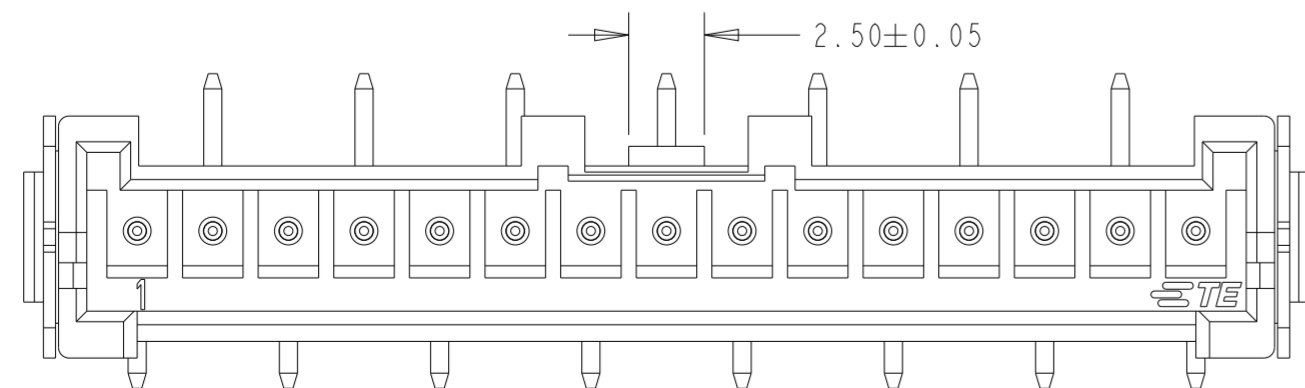

15 POSITION

THE DETAIL FEATURE OF ALL POSITION PRODUCT.

THIS DRAWING IS A CONTROLLED DOCUMENT.		DWN W. HUO	15APR2020	 TE Connectivity
DIMENSIONS: mm		CHK D. ZHANG	17APR2020	
TOLERANCES UNLESS OTHERWISE SPECIFIED:		APVD D. ZHANG	17APR2020	NAME HEADER ASSEMBLY, GWT, SMT TYPE, VERTICAL, SINGLE ROW, EP2.5
0 PLC ±		PRODUCT SPEC	108-2418	
1 PLC ±		APPLICATION SPEC	114-13315	SIZE A2
2 PLC ±0.25		WEIGHT	-	CAGE CODE 00779
3 PLC ±		CUSTOMER DRAWING	SCALE N/A	DRAWING NO C-2365497
4 PLC ±				RESTRICTED TO -
ANGLES ±3°				SCALE N/A SHEET 3 OF 4 REV B2
FINISH				

REVISIONS					
P	LTR	DESCRIPTION	DATE	DWN	APVD
-		SEE SHEET 1	-	-	-

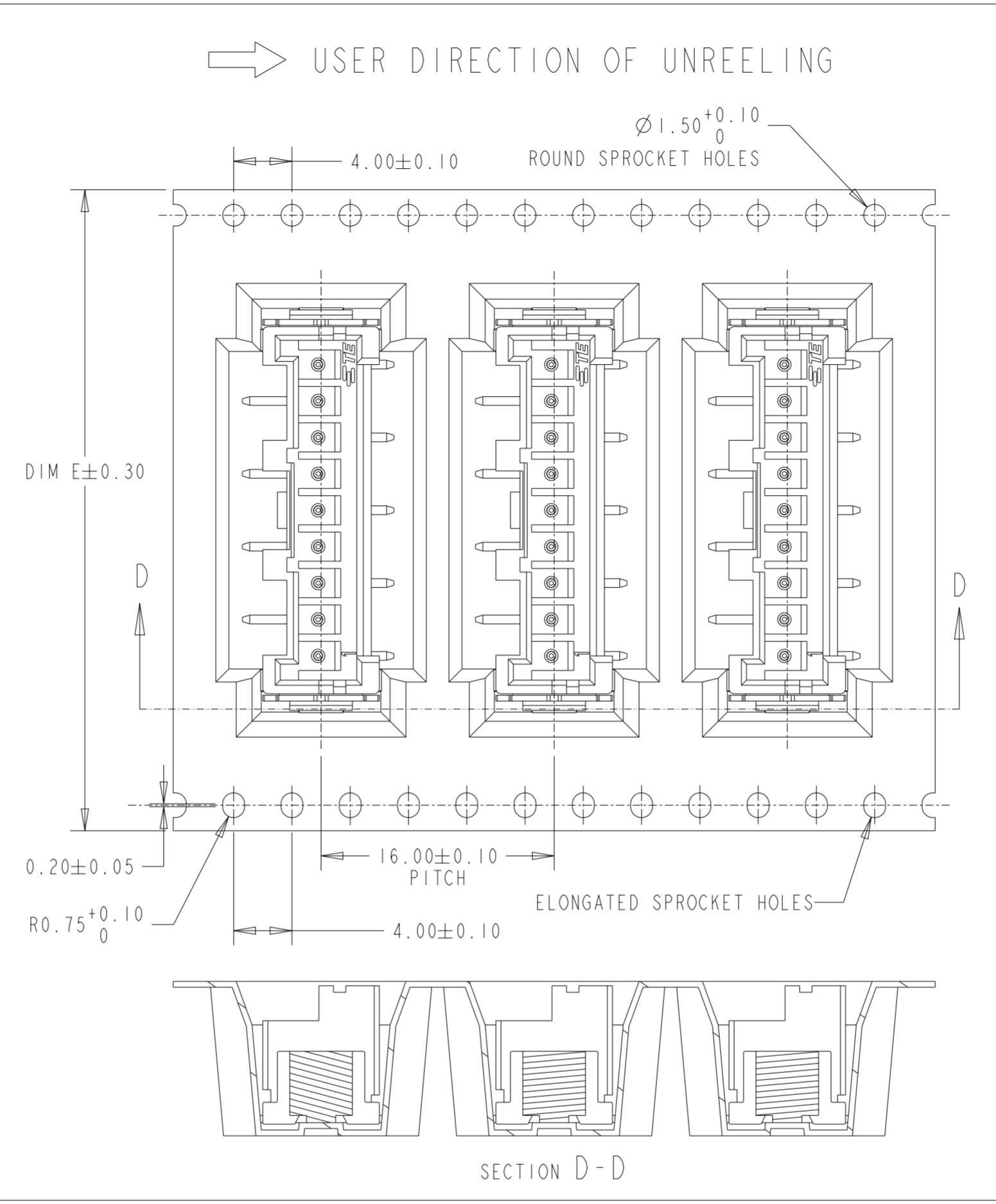
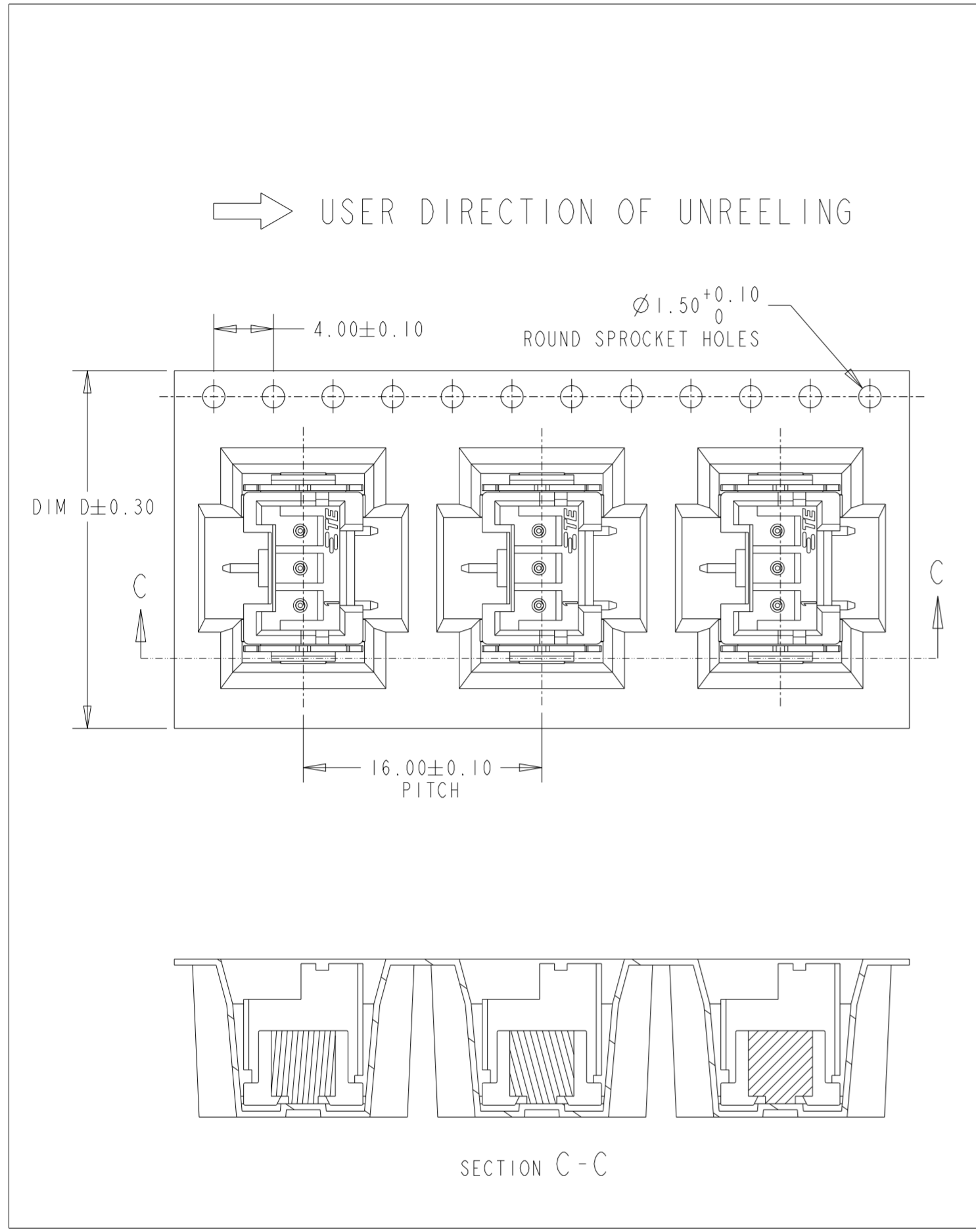

- NOTES FOR PACKAGE:
- 7. UNLESS OTHERWISE SPECIFIED TOLERANCE PER EIA-481.
 - 8. EMBOSS TAPE PEELING STRENGTH :
0.1N ~ 1.3N FOR 12MM TO 56MM WIDE CARRIER TAPES(2~14P)
0.1N ~ 1.5N FOR 72MM WIDE CARRIER TAPES(15P)
 - 9. PEELING CONDITION
PEELING ANGLE : 165~180°
PEELING SPEED : 300mm/MINUTE

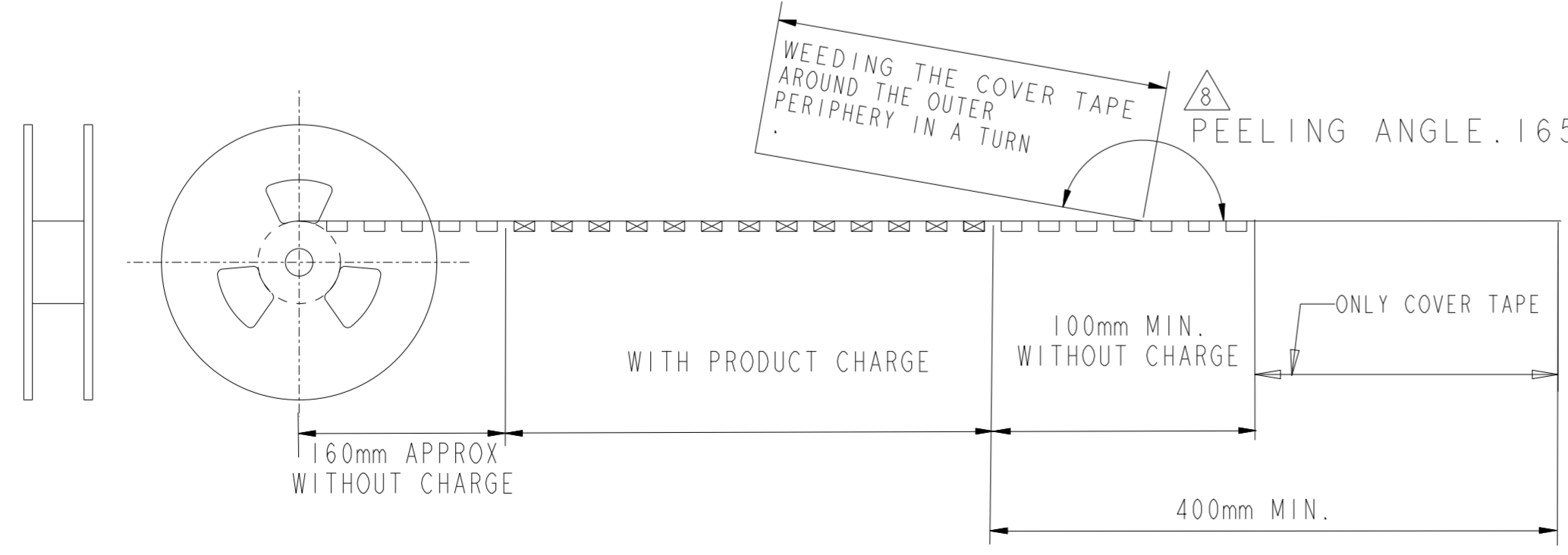

DIM E	/	32.0	44.0	56.0	72.0
DIM D	24.0	/	/	/	/
POSITION	2P, 3P, 4P	5P	6P~10P	11P~14P	15P

THIS DRAWING IS A CONTROLLED DOCUMENT.

DIMENSIONS:	TOLERANCES UNLESS OTHERWISE SPECIFIED:	DWN	15APR2020
mm	0 PLC ±	CHK	17APR2020
	1 PLC ±	D	ZHANG
	2 PLC ±0.25	APVD	17APR2020
	3 PLC ±	D	ZHANG
	4 PLC ±	PRODUCT SPEC	108-2418
	ANGLES ±3°	APPLICATION SPEC	114-13315
	FINISH	WEIGHT	-
MATERIAL		CUSTOMER DRAWING	

TE Connectivity

NAME: HEADER ASSEMBLY, GWT, SMT TYPE, VERTICAL, SINGLE ROW, EP2.5

SIZE	CAGE CODE	DRAWING NO	RESTRICTED TO
A2	00779	C-2365497	-

SCALE N/A SHEET 4 OF 4 REV B2