

THIS DRAWING IS UNPUBLISHED.

RELEASED FOR PUBLICATION

20

© COPYRIGHT 2020 TE Connectivity. All Rights Reserved. ALL RIGHTS RESERVED.

| LOC | DIST | REVISIONS   |                       |           |       |
|-----|------|-------------|-----------------------|-----------|-------|
| P   | LTR  | DESCRIPTION | DATE                  | DWN       | APVD  |
| -   | -    | A           | RELEASE TO PRODUCTION | 22JUN2022 | SS PP |
|     |      |             |                       |           |       |
|     |      |             |                       |           |       |

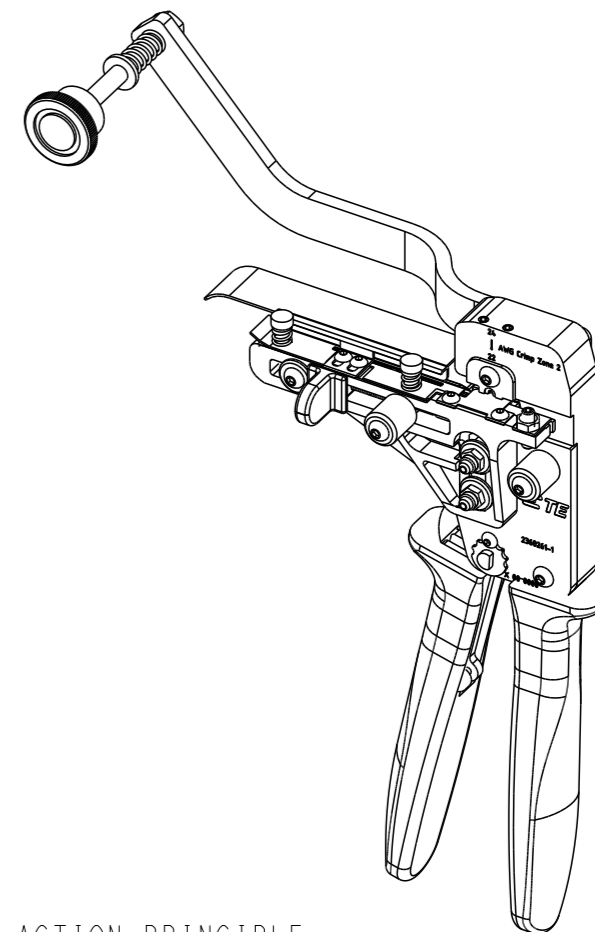
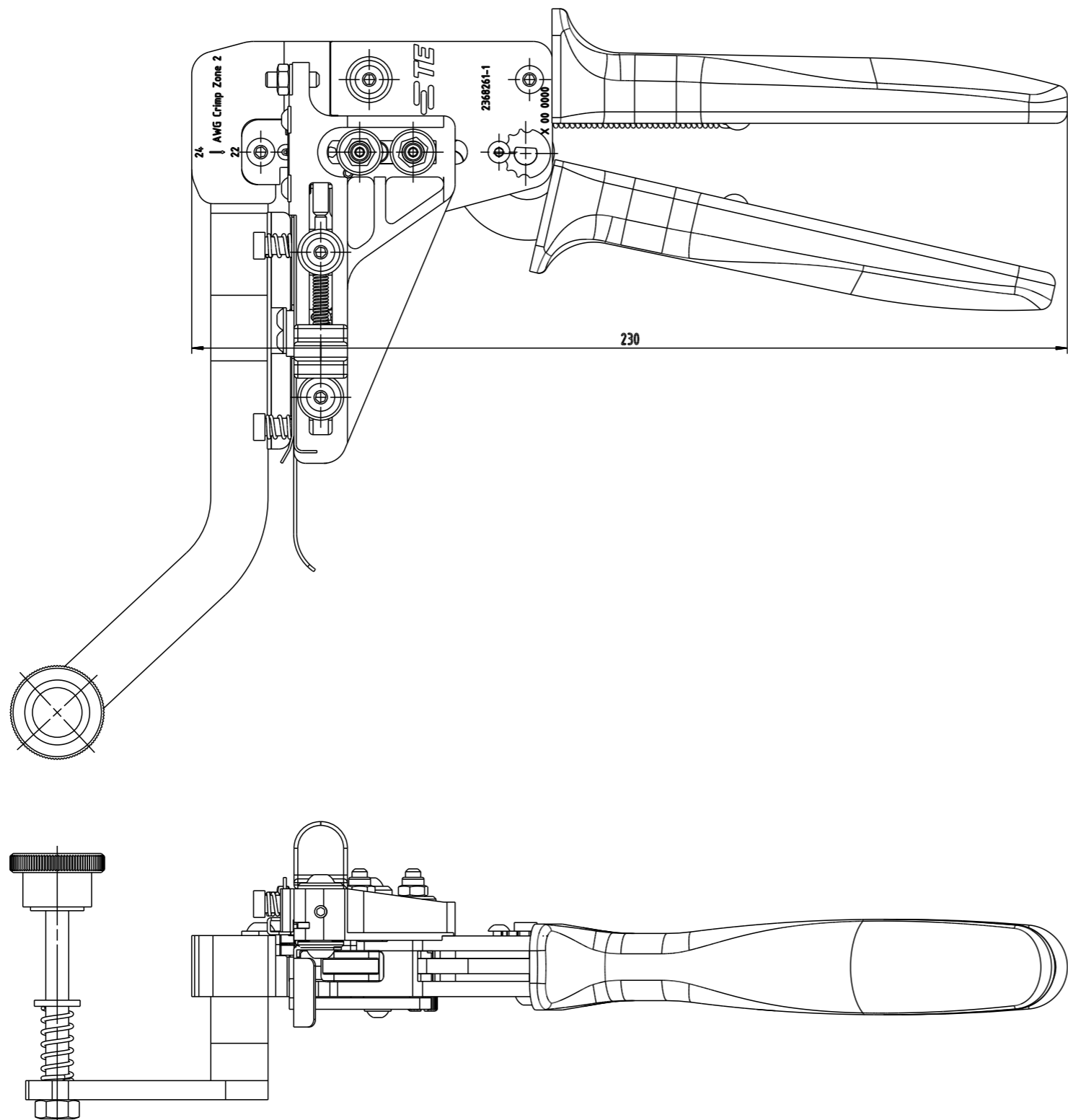

NOTES:

1. STRAIGHT ACTION PRINCIPLE;
2. RATCHED RELEASE;
3. SIMPLE PRESSURE ADJUSTMENT WITH LOCKING DEVICE;
4. FEEDING AND CUTTING DEVICE
5. PRECISELY GROUND PROFILES;
6. ERGONOMIC SOFT GRIPS, COLOUR TRAFFIC BLUE (RAL 5017);
7. FULLY RECYCLABLE;
8. APPLICATION RANGE: T1 INDUSTRIAL CONTACTS;
9. CROSS SECTION RANGE: AWG 24-22
10. REEL WITH CONTACTS (500 PCS) IS INCLUDED, (NOT SHOWN IN PICTURES)

PARTNUMBER:  
2368261-1

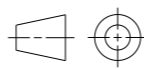
|   |  |                                   |   |                    |
|---|--|-----------------------------------|---|--------------------|
| THIS DRAWING IS A CONTROLLED DOCUMENT.  |  | DWN<br>S. SHARMA<br>15JUN2022     |  TE Connectivity |                    |
| DIMENSIONS:<br>mm   |  | CHK<br>P. POORTER<br>21JUN2022    |   |                    |
|  |  | APVD<br>J. DE BRUIJN<br>22JUN2022 | NAME<br>SPE T1 MANUAL CRIMP TOOL AWG 24-22  |                    |
| TOLERANCES UNLESS OTHERWISE SPECIFIED:  |  | PRODUCT SPEC                      | RESTRICTED TO   |                    |
| 0 PLC ±<br>1 PLC ±0.1<br>2 PLC ±0.01<br>3 PLC ±0.001<br>4 PLC ±0.0001<br>ANGLES ±     |  | APPLICATION SPEC                  | SIZE<br>A3  | CAGE CODE<br>00779 |
| MATERIAL -  |  | WEIGHT -                          | DRAWING NO<br>C-2368261   | SCALE<br>NTS       |
| FINISH -  |  | CUSTOMER DRAWING                  | SHEET 1 OF 1  | REV A              |