

REVISIONS					
P	LTR	DESCRIPTION	DATE	DWN	APVD
1		NEW DRAWING	19JUL2022	GSK	AS

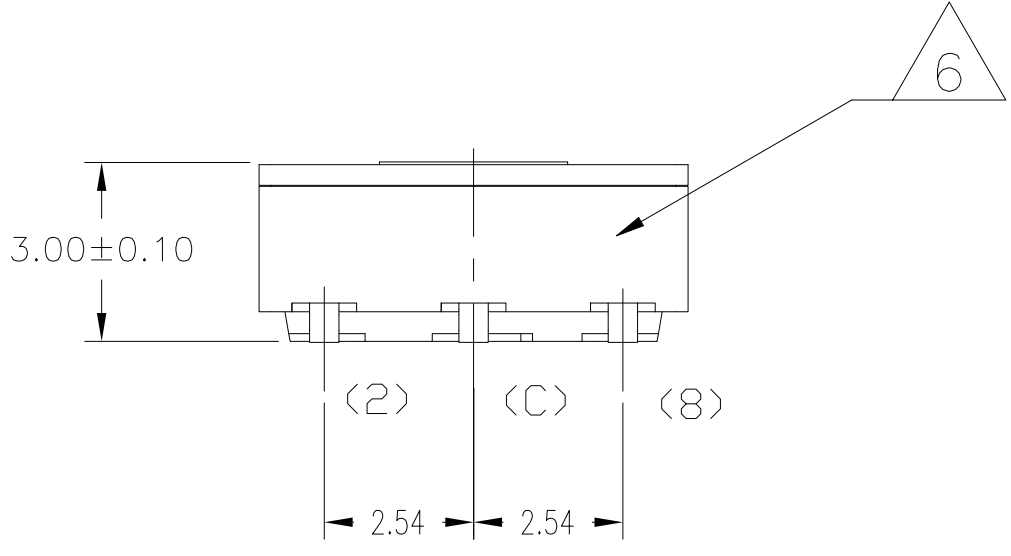

CODE BINARY
 (COMPLEMENT/GRAY/REAL)
 J-LEAD TERMINALS
 COVER COLOR BLACK
 PRINT MARKING
 10 POSITION

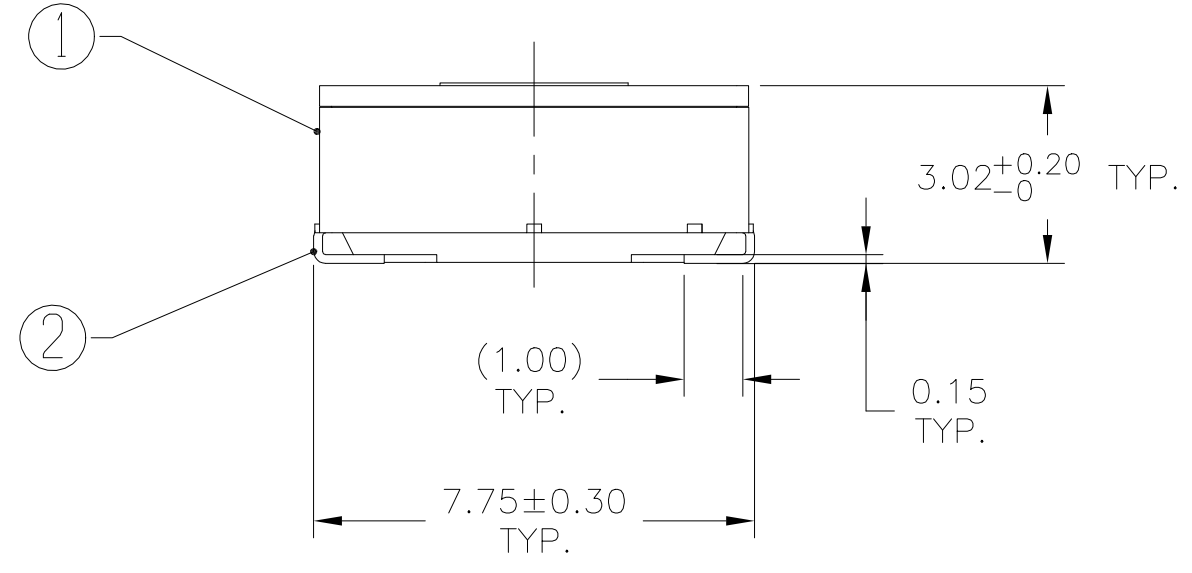
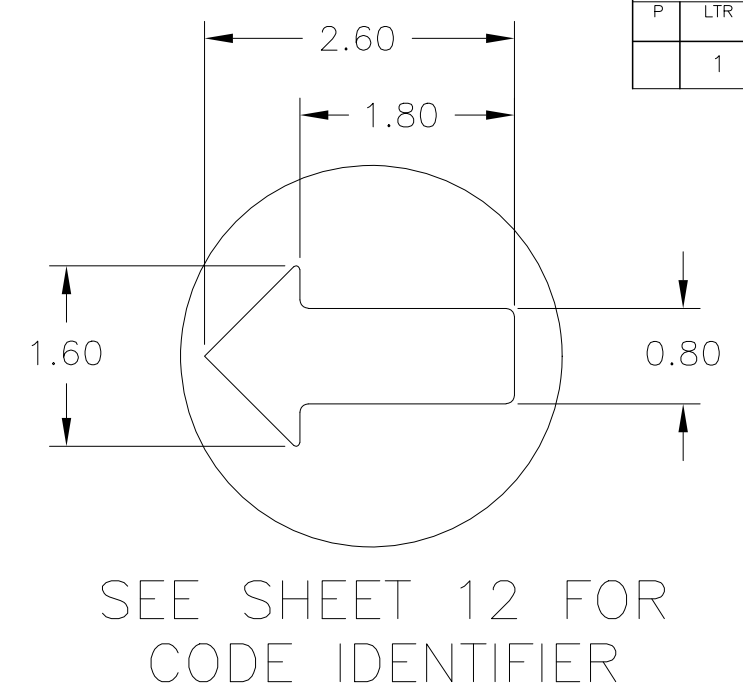
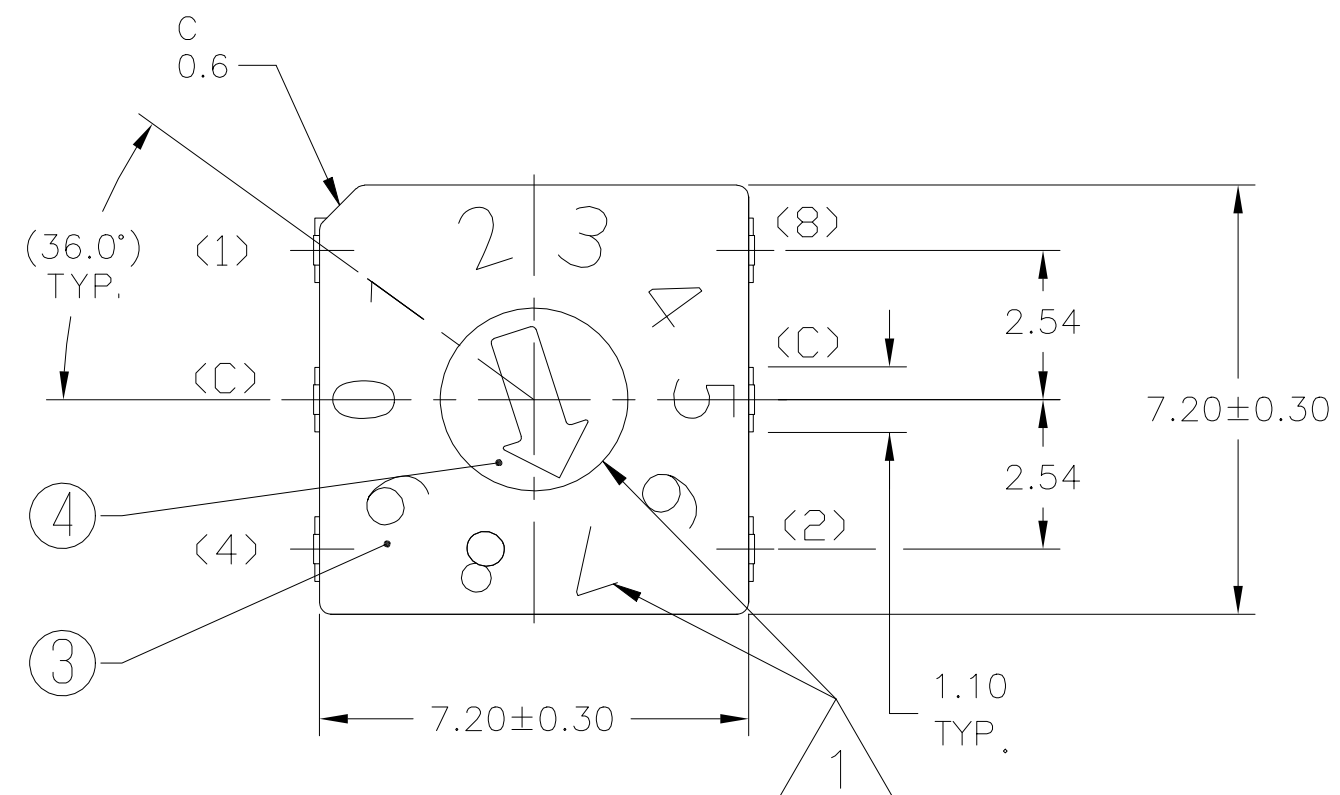
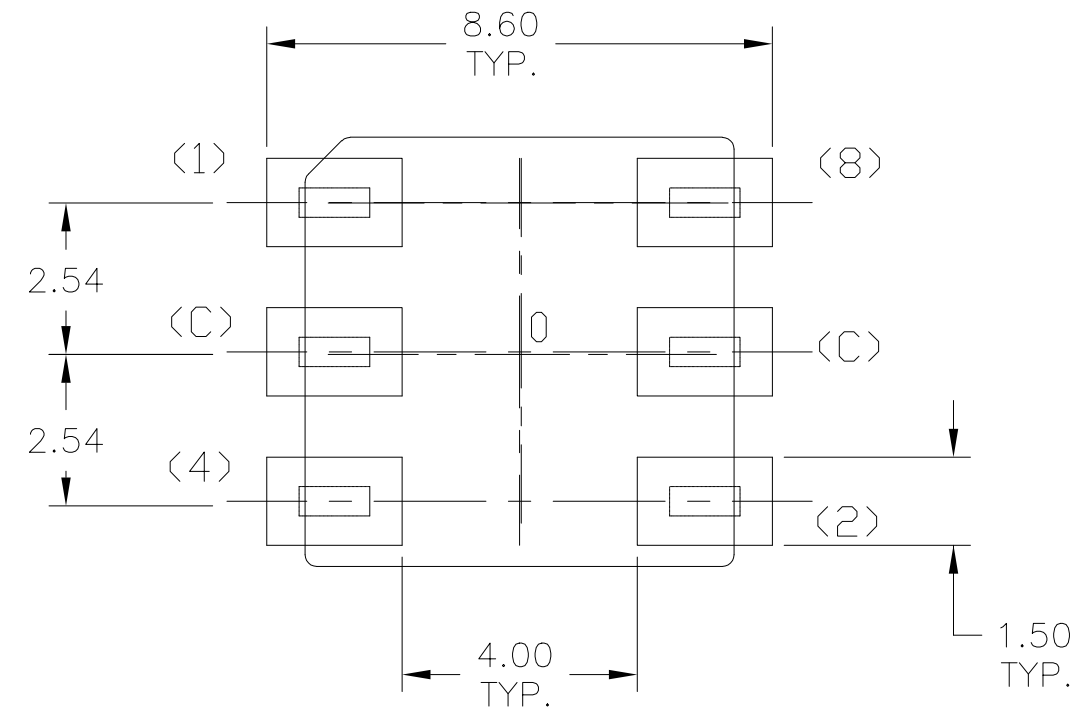
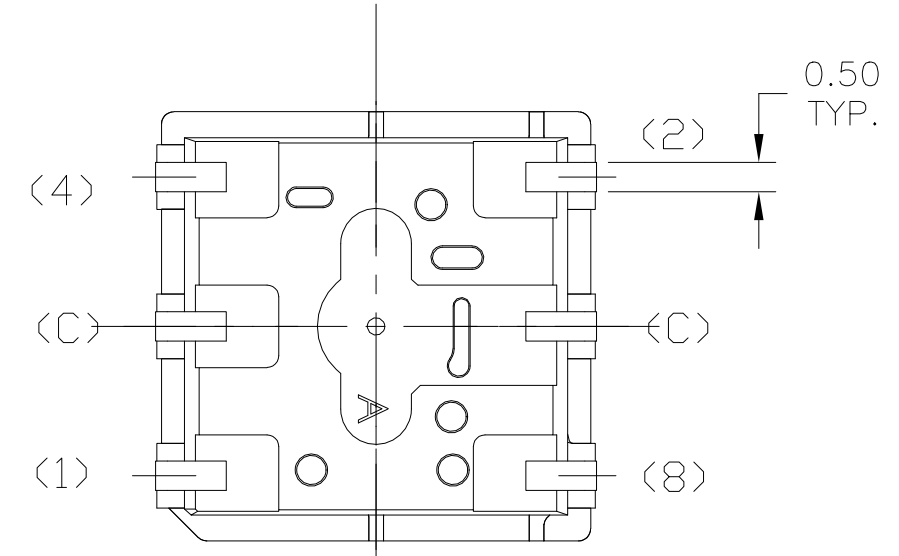

PCB Layout

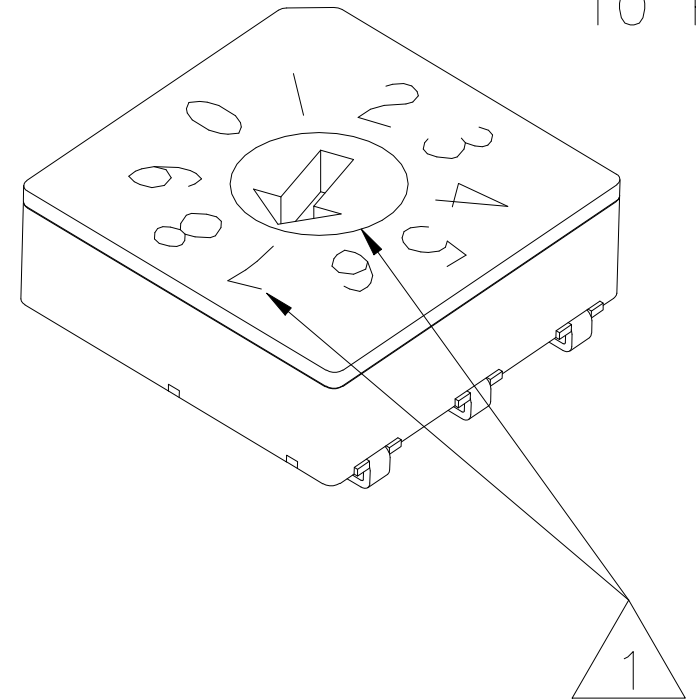

PRELIMINARY

THIS DRAWING IS A CONTROLLED DOCUMENT.		DWN 19JUL2022 SATHISH KUMAR_G		MRSS, MINIATURE ROTARY SWITCH SERIES, VERTICAL, 2.54 BLACK, PRINT MARKING																		
DIMENSIONS: mm		CHK 19JUL2022 ALEXANDER, SHARPE		NAME																		
TOLERANCES UNLESS OTHERWISE SPECIFIED: ±0.15		APVD 19JUL2022 ALEXANDER, SHARPE	PRODUCT SPEC		RESTRICTED TO																	
<table border="1"> <tr><td>0 PLC</td><td>±</td><td>-</td></tr> <tr><td>1 PLC</td><td>±</td><td>-</td></tr> <tr><td>2 PLC</td><td>±</td><td>-</td></tr> <tr><td>3 PLC</td><td>±</td><td>-</td></tr> <tr><td>4 PLC</td><td>±</td><td>-</td></tr> <tr><td>ANGLES</td><td>±</td><td>-</td></tr> </table>		0 PLC	±	-	1 PLC	±	-	2 PLC	±	-	3 PLC	±	-	4 PLC	±	-	ANGLES	±	-	APPLICATION SPEC		SIZE A2
0 PLC	±	-																				
1 PLC	±	-																				
2 PLC	±	-																				
3 PLC	±	-																				
4 PLC	±	-																				
ANGLES	±	-																				
MATERIAL		WEIGHT		CAGE CODE 00779																		
		FINISH		DRAWING NO. C=2396234																		
		CUSTOMER DRAWING		SCALE 8:1																		
				SHEET 1 OF 12																		
				REV 1																		

REVISIONS					
P	LTR	DESCRIPTION	DATE	DWN	APVD
-	-	SEE SHEET 1	-	-	-

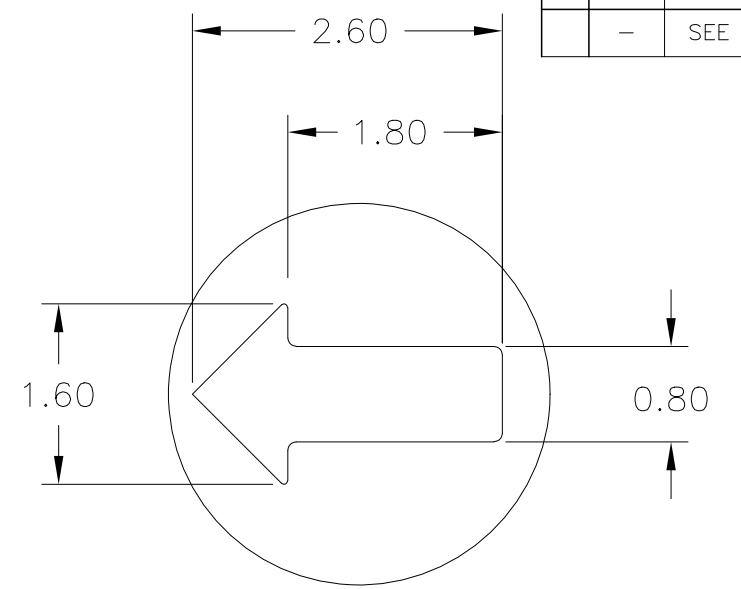
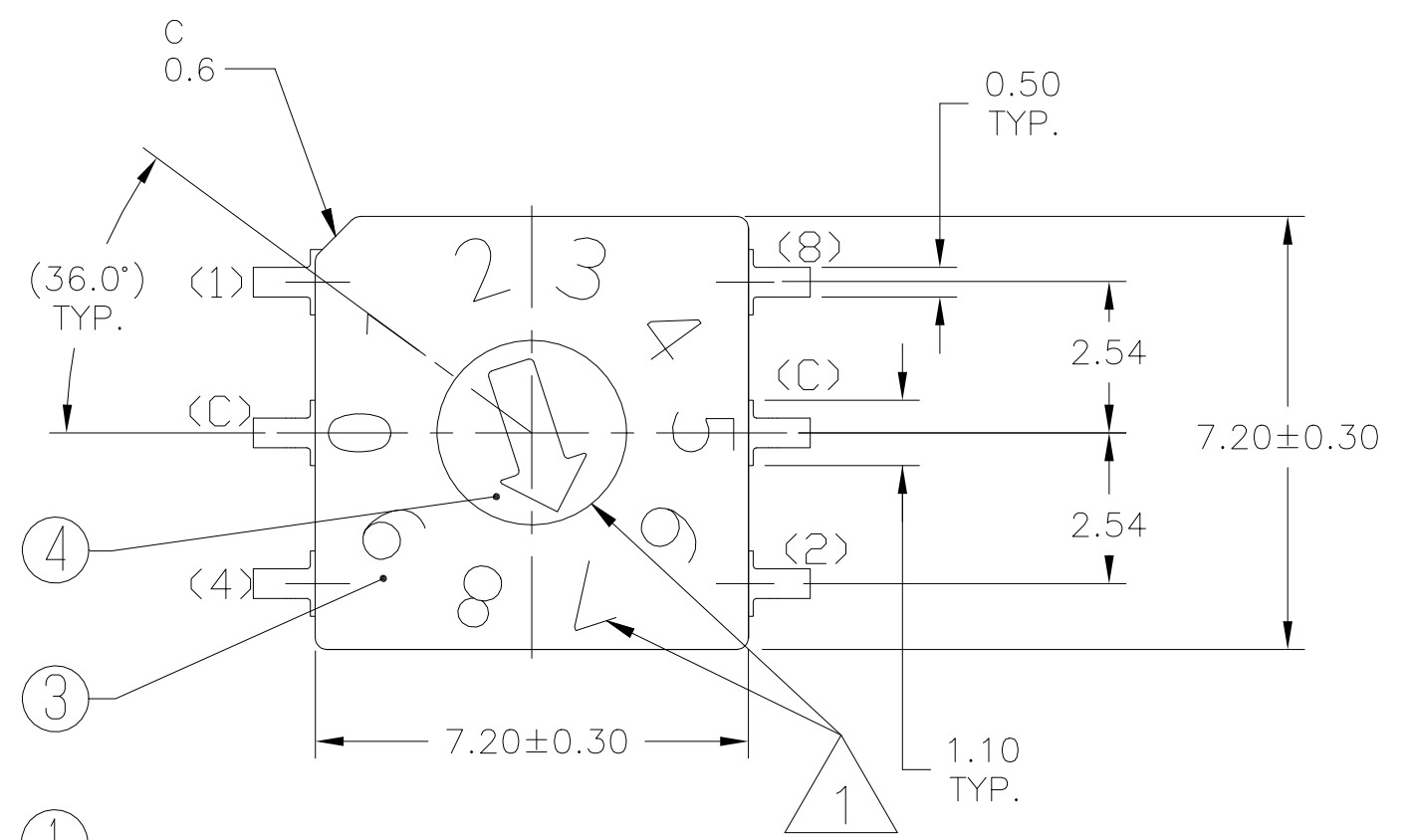

SEE SHEET 12 FOR CODE IDENTIFIER

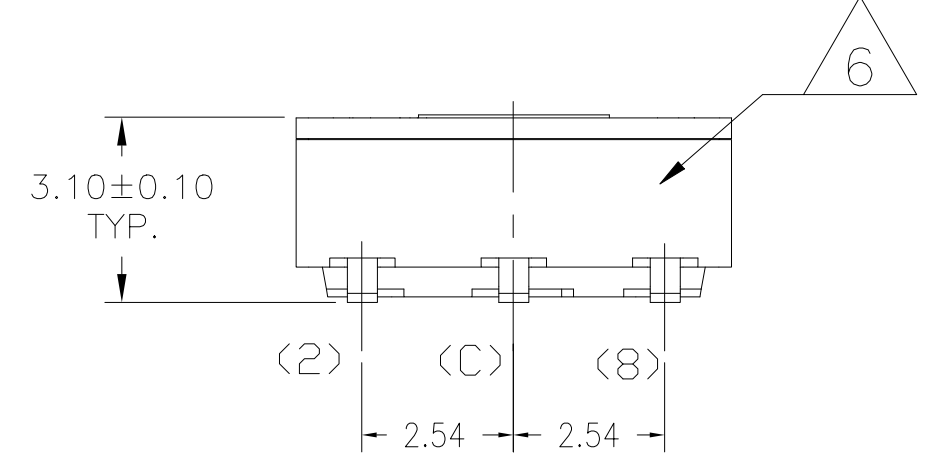
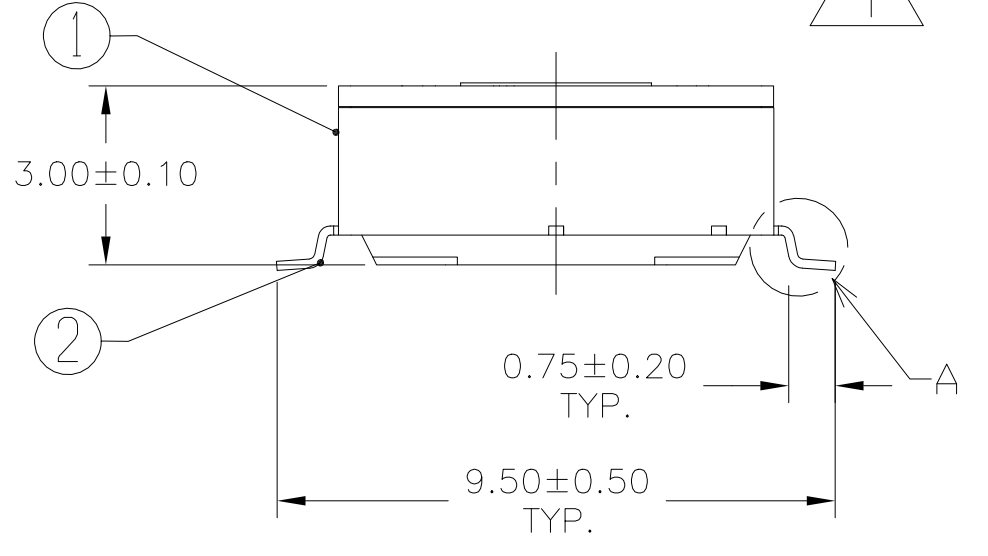

CODE BINARY
(COMPLEMENT/GRAY/REAL)
GULLWING TERMINALS
COVER COLOR BLACK
PRINT MARKING
10 POSITION

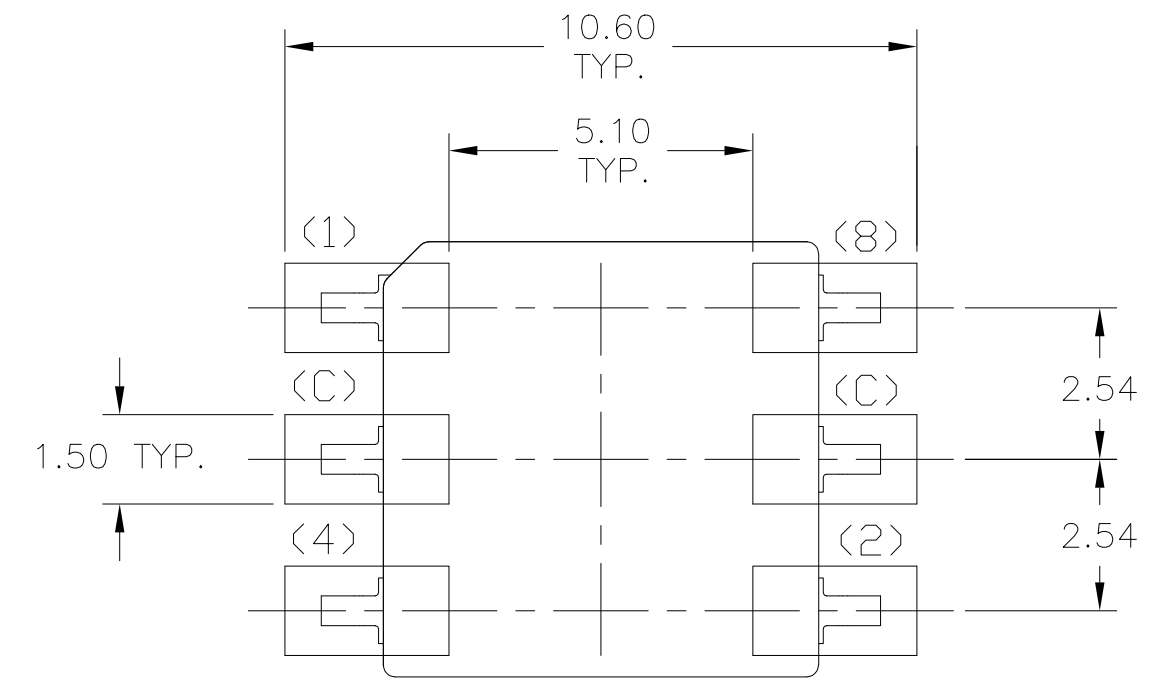
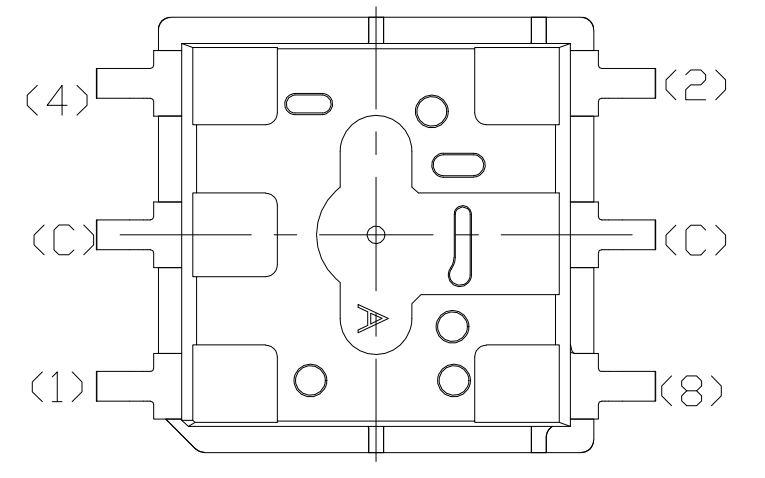

PCB Layout

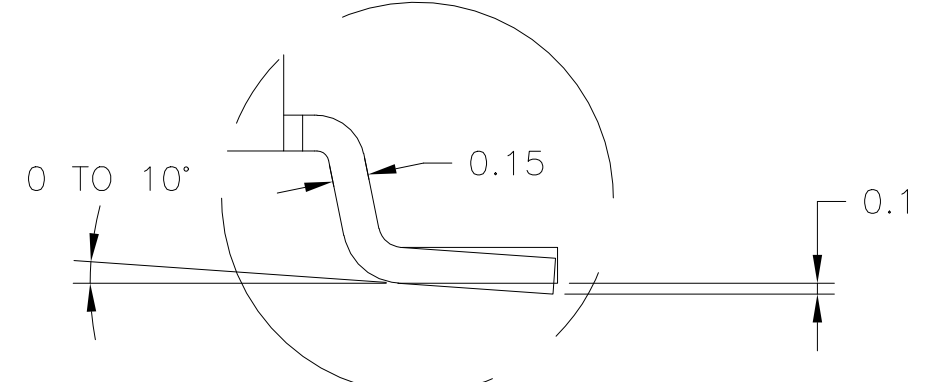
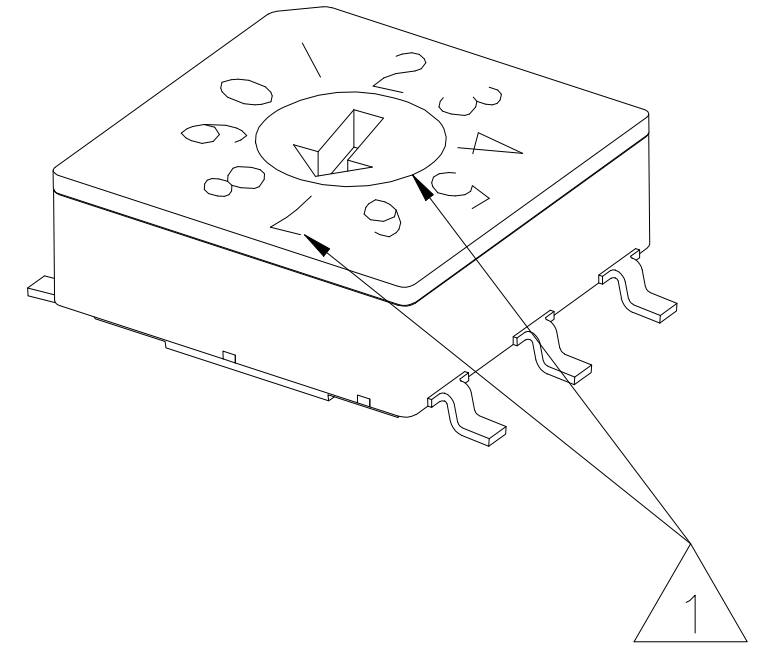

A Detail TYP.

PRELIMINARY

THIS DRAWING IS A CONTROLLED DOCUMENT.		DWN 19JUL2022 SATHISH KUMAR_G	TE Connectivity																			
DIMENSIONS: mm		CHK 19JUL2022 ALEXANDER, SHARPE																				
TOLERANCES UNLESS OTHERWISE SPECIFIED: ±0.15		APVD 19JUL2022 ALEXANDER, SHARPE	NAME MRSS, MINIATURE ROTARY SWITCH SERIES, VERTICAL, 2.54 BLACK, PRINT MARKING																			
<table border="1"> <tr><td>0 PLC</td><td>±</td><td>=</td></tr> <tr><td>1 PLC</td><td>±</td><td>=</td></tr> <tr><td>2 PLC</td><td>±</td><td>=</td></tr> <tr><td>3 PLC</td><td>±</td><td>=</td></tr> <tr><td>4 PLC</td><td>±</td><td>=</td></tr> <tr><td>ANGLES</td><td>±</td><td>=</td></tr> </table>		0 PLC	±	=	1 PLC	±	=	2 PLC	±	=	3 PLC	±	=	4 PLC	±	=	ANGLES	±	=	PRODUCT SPEC	RESTRICTED TO	
0 PLC	±	=																				
1 PLC	±	=																				
2 PLC	±	=																				
3 PLC	±	=																				
4 PLC	±	=																				
ANGLES	±	=																				
MATERIAL		APPLICATION SPEC	SIZE A2	CAGE CODE 00779																		
FINISH		WEIGHT	DRAWING NO. C=2396234	SCALE 8:1																		
		CUSTOMER DRAWING	SHEET 2 OF 12	REV 1																		

REVISIONS					
P	LTR	DESCRIPTION	DATE	DWN	APVD
-	-	SEE SHEET 1	-	-	-

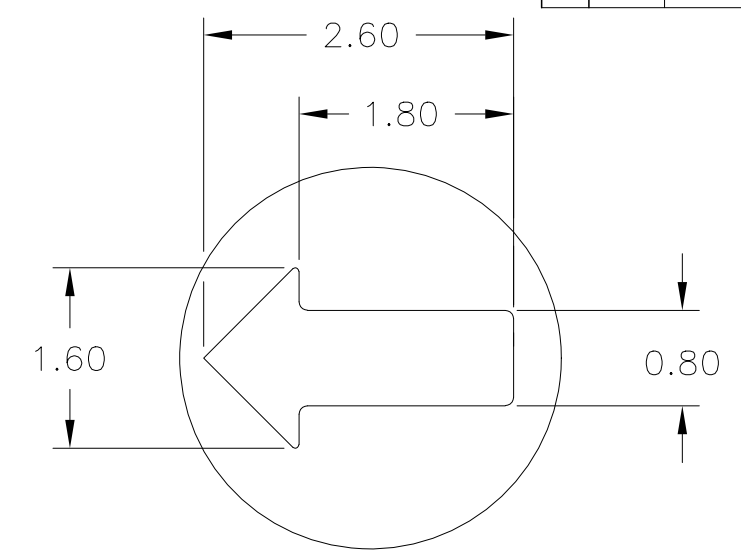
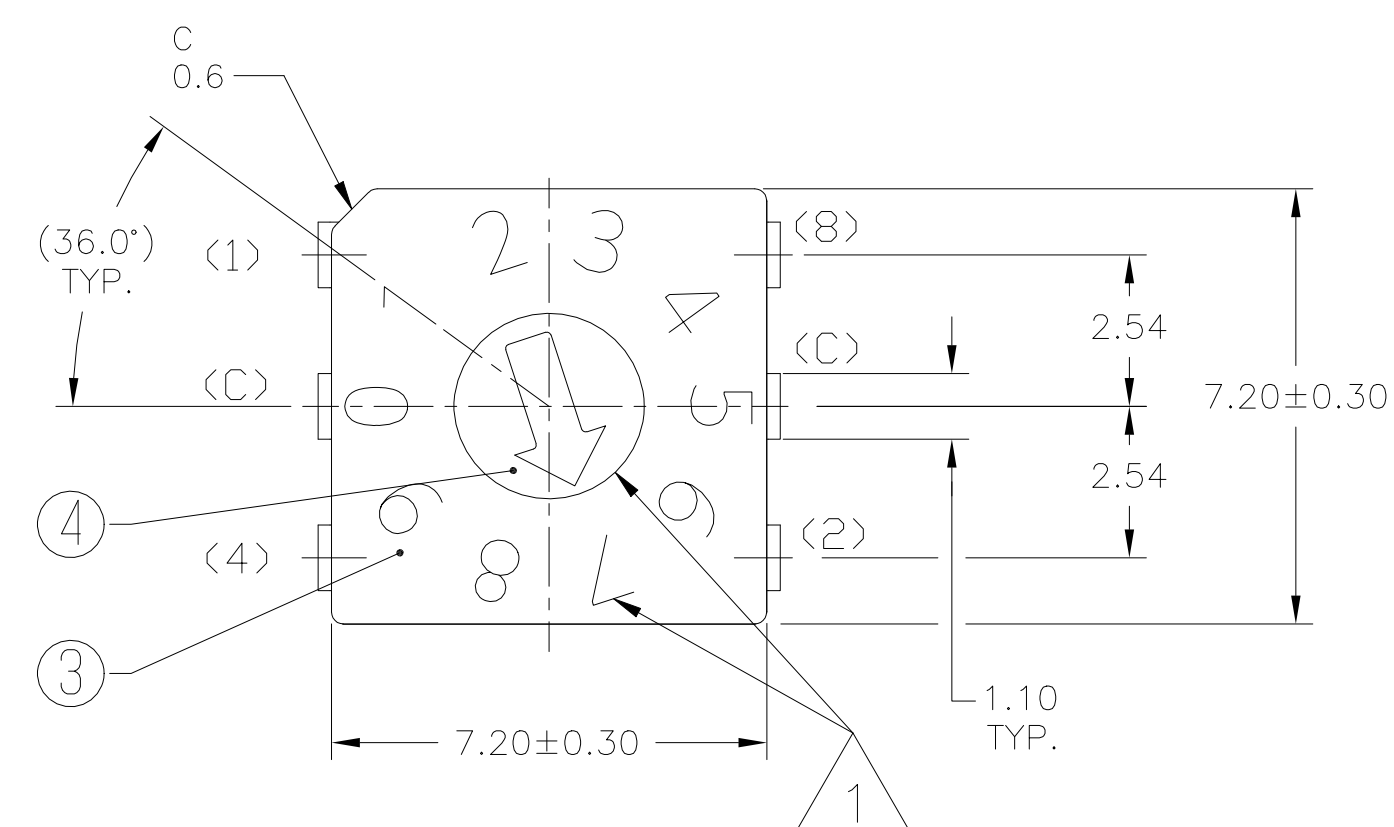

SEE SHEET 12 FOR CODE IDENTIFIER

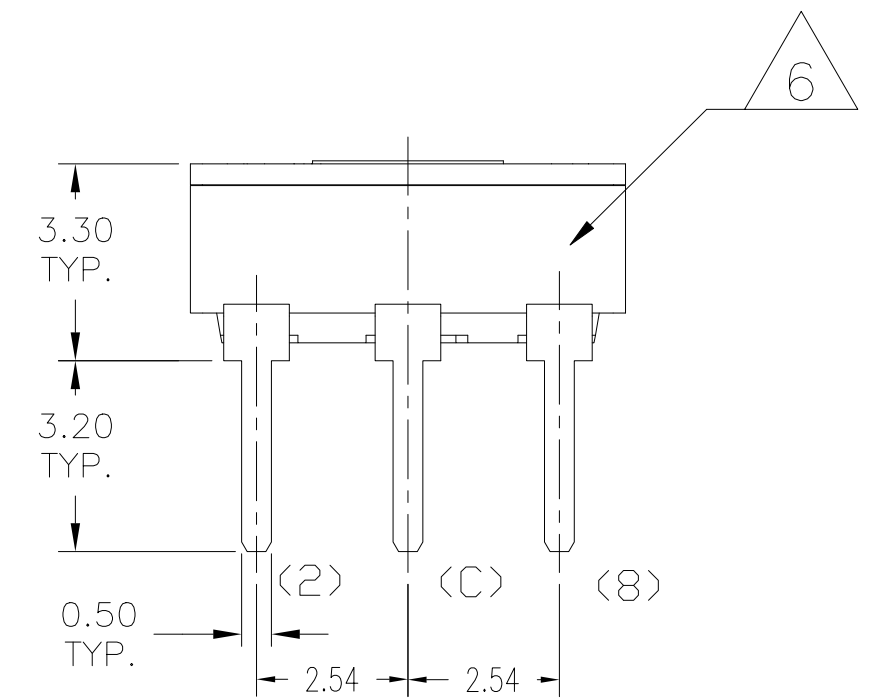
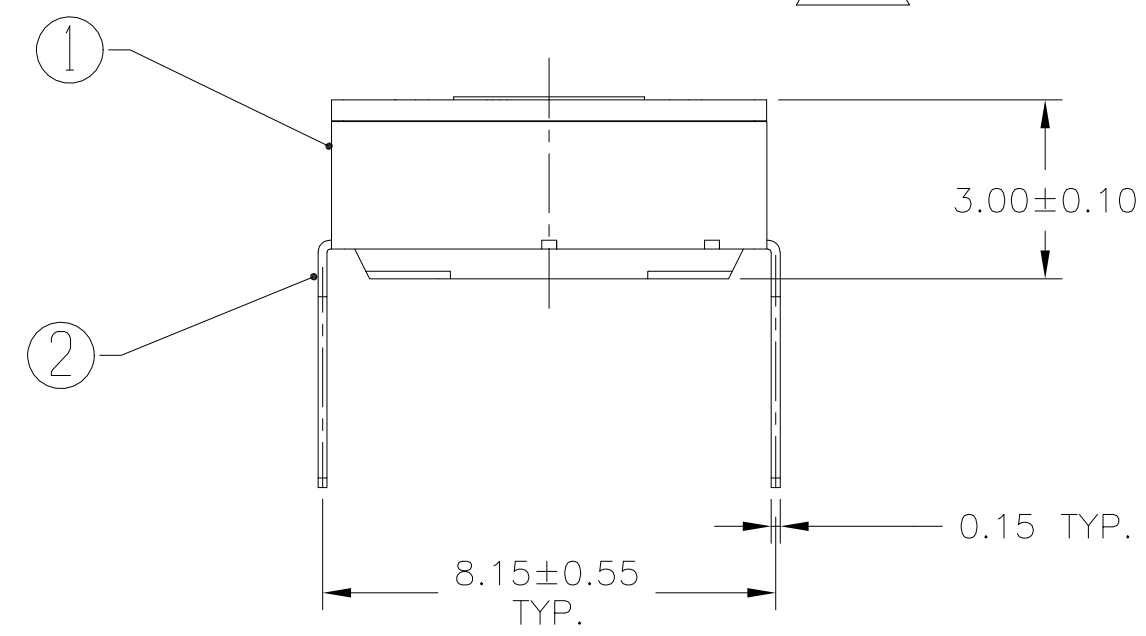

CODE BINARY
(COMPLEMENT/GRAY/REAL)
THROUGH-HOLE TERMINALS
COVER COLOR BLACK
PRINT MARKING
10 POSITIONS

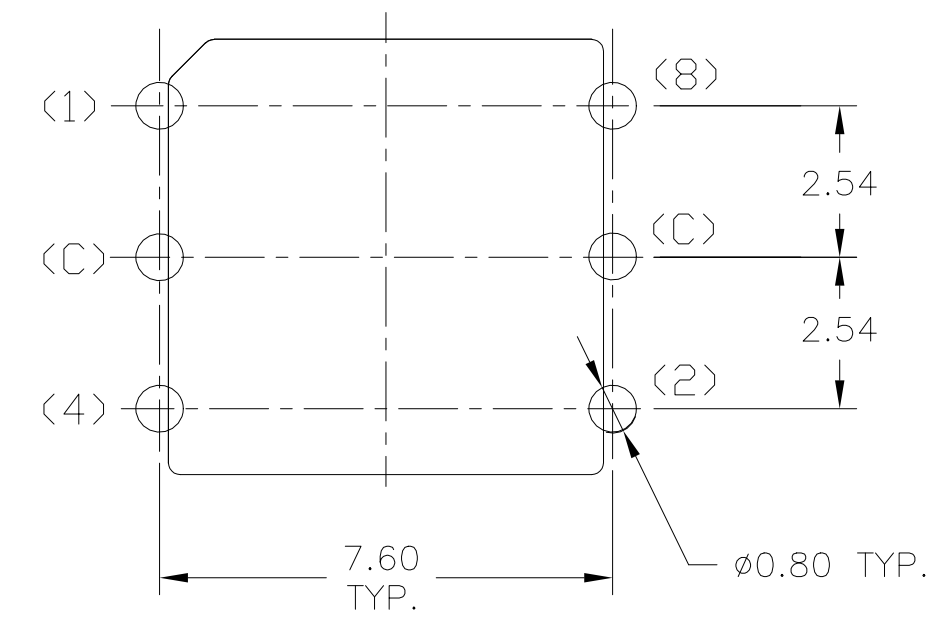
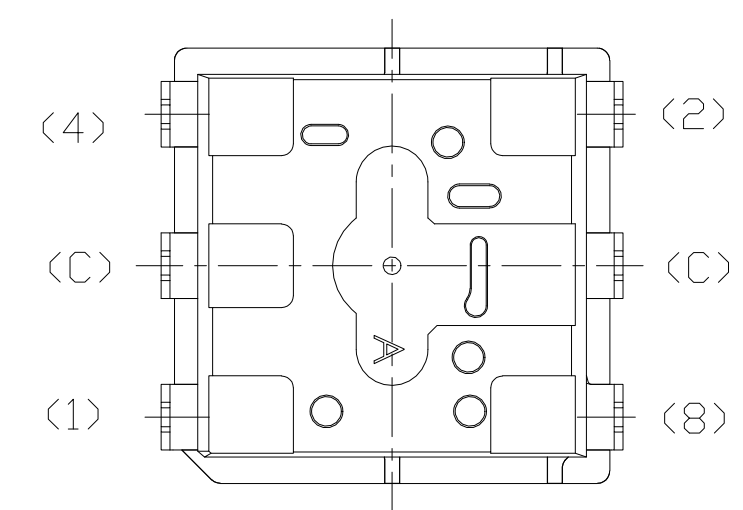

PCB Layout

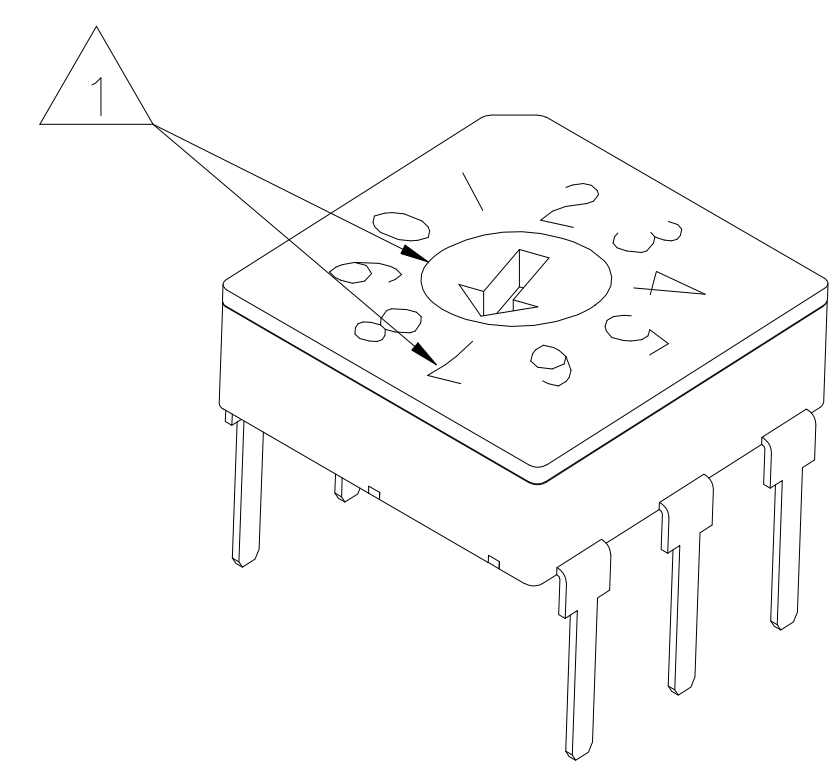

PRELIMINARY

THIS DRAWING IS A CONTROLLED DOCUMENT.		DWN 19JUL2022 SATHISH KUMAR_G	TE Connectivity																			
DIMENSIONS: mm		CHK 19JUL2022 ALEXANDER, SHARPE																				
TOLERANCES UNLESS OTHERWISE SPECIFIED: ±0.15		APVD 19JUL2022 ALEXANDER, SHARPE	NAME MRSS, MINIATURE ROTARY SWITCH SERIES, VERTICAL, 2.54 BLACK, PRINT MARKING																			
<table border="1"> <tr><td>0 PLC</td><td>±</td><td>-</td></tr> <tr><td>1 PLC</td><td>±</td><td>-</td></tr> <tr><td>2 PLC</td><td>±</td><td>-</td></tr> <tr><td>3 PLC</td><td>±</td><td>-</td></tr> <tr><td>4 PLC</td><td>±</td><td>-</td></tr> <tr><td>ANGLES</td><td>±</td><td>-</td></tr> </table>		0 PLC	±	-	1 PLC	±	-	2 PLC	±	-	3 PLC	±	-	4 PLC	±	-	ANGLES	±	-	PRODUCT SPEC	RESTRICTED TO	
0 PLC	±	-																				
1 PLC	±	-																				
2 PLC	±	-																				
3 PLC	±	-																				
4 PLC	±	-																				
ANGLES	±	-																				
MATERIAL		APPLICATION SPEC	SIZE A2	CAGE CODE 00779																		
FINISH		WEIGHT	DRAWING NO. C=2396234	SCALE 8:1																		
		CUSTOMER DRAWING	SHEET 3 OF 12	REV 1																		

REVISIONS					
P	LTR	DESCRIPTION	DATE	DWN	APVD
-	-	SEE SHEET 1	-	-	-

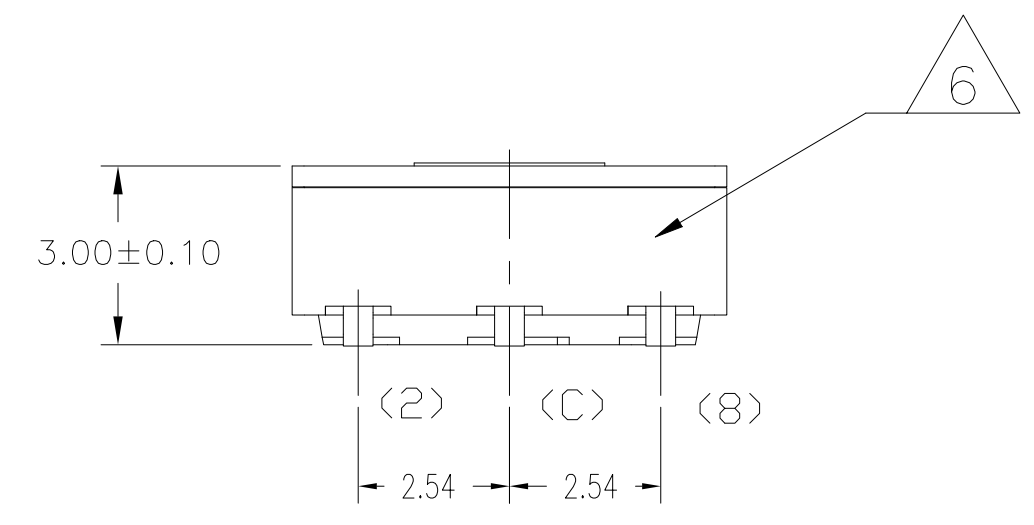
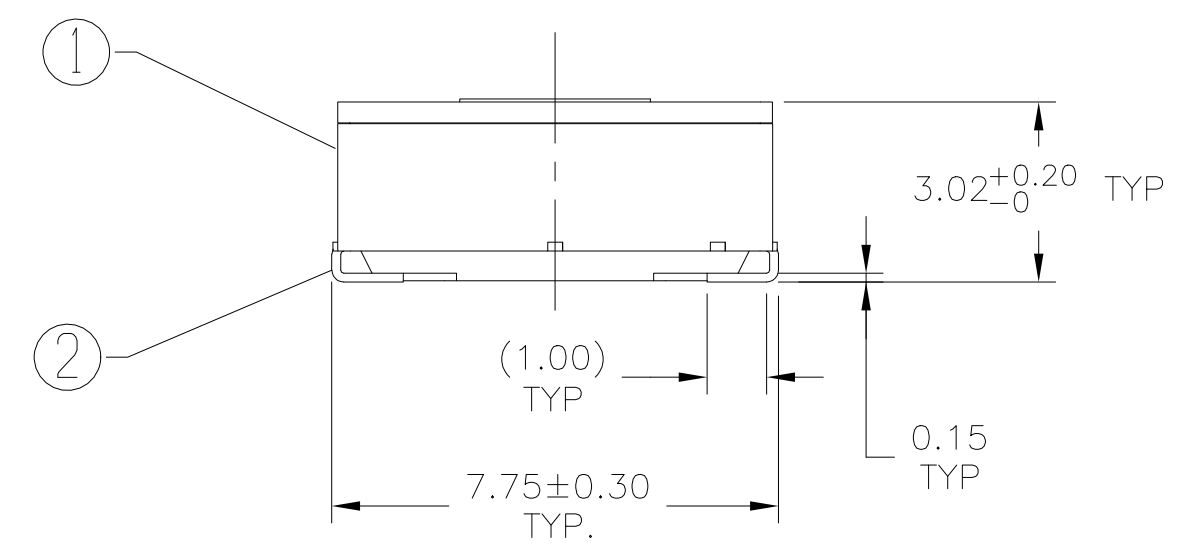
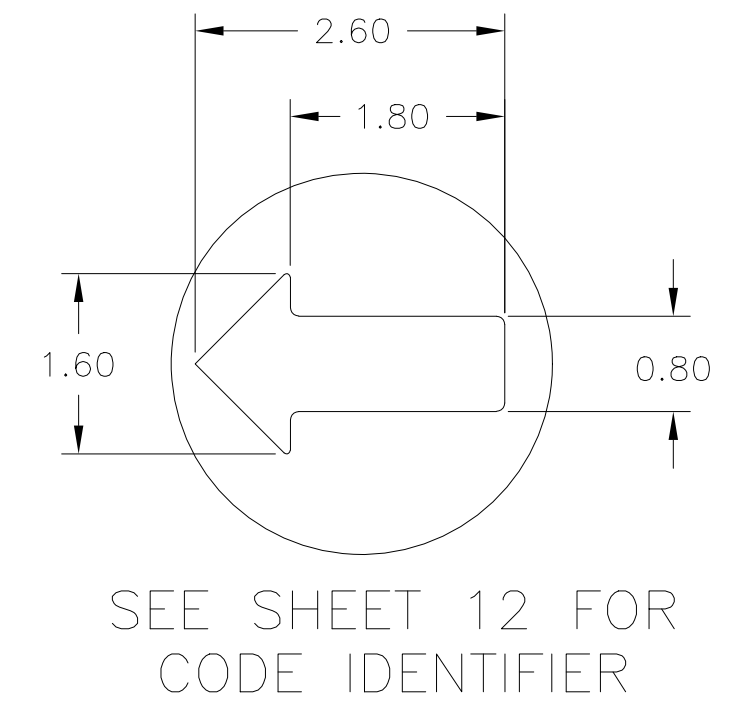
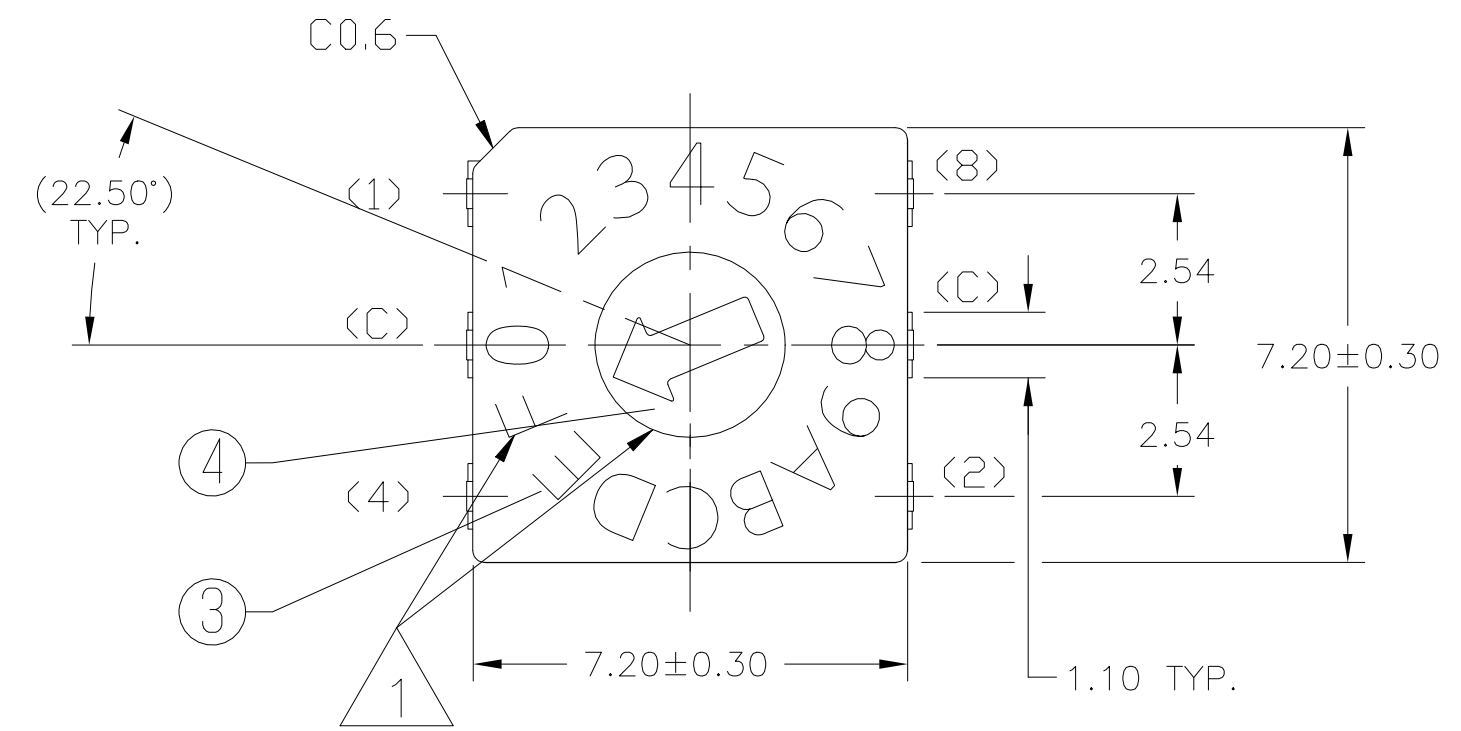

CODE HEXADECIMAL
 (COMPLEMENT/GRAY/REAL)
 J-LEAD TERMINALS
 COVER COLOR BLACK
 PRINT MARKING
 16 POSITION

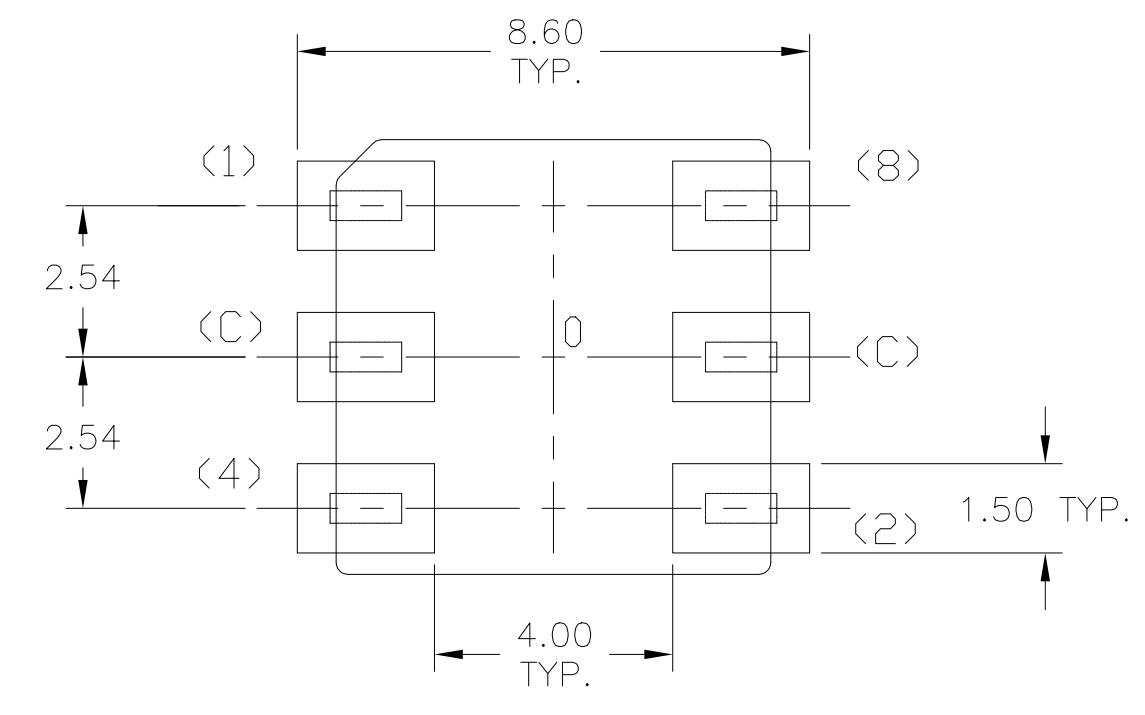
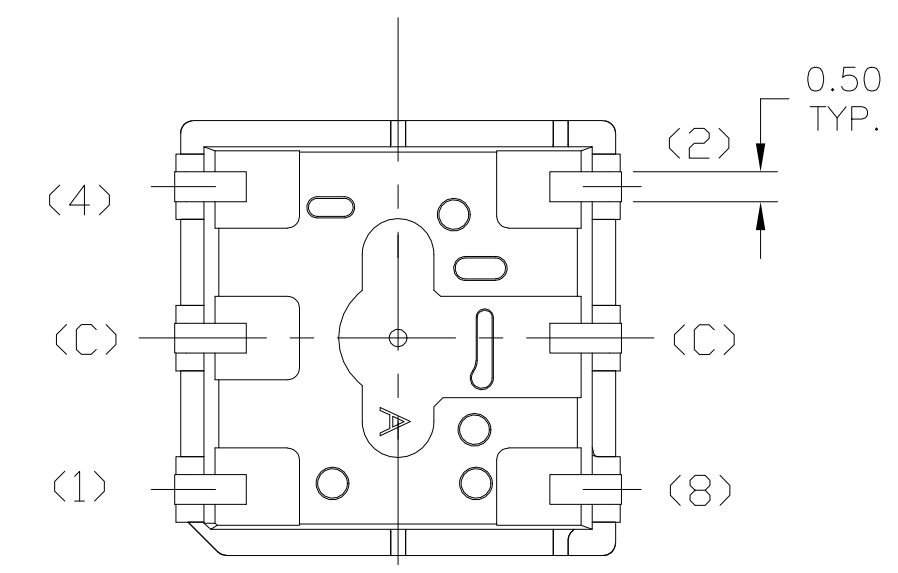

PCB Layout

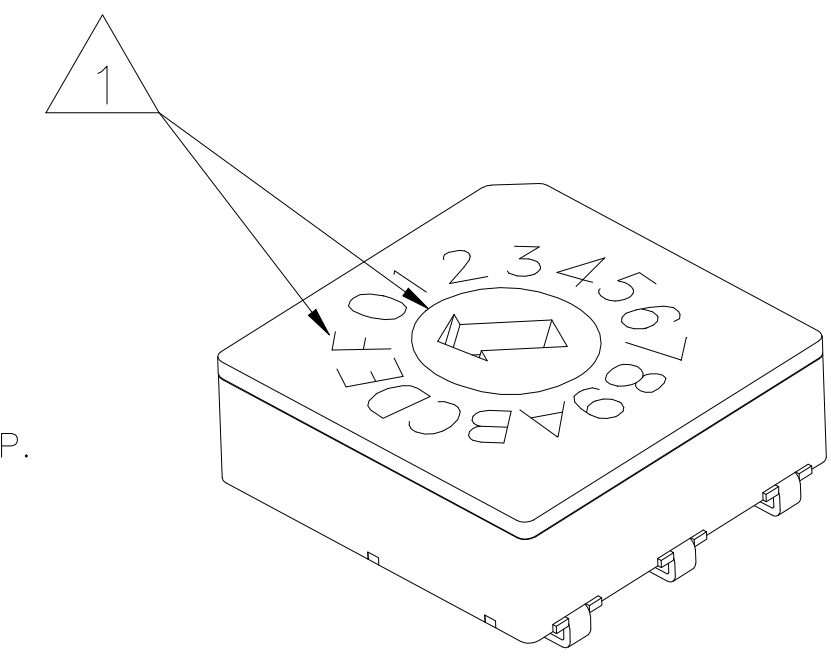

PRELIMINARY

THIS DRAWING IS A CONTROLLED DOCUMENT.		DWN 19JUL2022 SATHISH KUMAR_G	TE Connectivity																			
DIMENSIONS: mm		CHK 19JUL2022 ALEXANDER, SHARPE																				
TOLERANCES UNLESS OTHERWISE SPECIFIED: ±0.15		APVD 19JUL2022 ALEXANDER, SHARPE	NAME MRSS, MINIATURE ROTARY SWITCH SERIES, VERTICAL, 2.54 BLACK, PRINT MARKING																			
<table border="1"> <tr><td>0 PLC</td><td>±</td><td>=</td></tr> <tr><td>1 PLC</td><td>±</td><td>=</td></tr> <tr><td>2 PLC</td><td>±</td><td>=</td></tr> <tr><td>3 PLC</td><td>±</td><td>=</td></tr> <tr><td>4 PLC</td><td>±</td><td>=</td></tr> <tr><td>ANGLES</td><td>±</td><td>=</td></tr> </table>		0 PLC	±	=	1 PLC	±	=	2 PLC	±	=	3 PLC	±	=	4 PLC	±	=	ANGLES	±	=	PRODUCT SPEC	RESTRICTED TO	
0 PLC	±	=																				
1 PLC	±	=																				
2 PLC	±	=																				
3 PLC	±	=																				
4 PLC	±	=																				
ANGLES	±	=																				
MATERIAL		APPLICATION SPEC	SIZE A2	CAGE CODE 00779																		
FINISH		WEIGHT	DRAWING NO. C=2396234	SCALE 8:1																		
		CUSTOMER DRAWING	SHEET 4 OF 12	REV 1																		

REVISIONS					
P	LTR	DESCRIPTION	DATE	DWN	APVD
-	-	SEE SHEET 1	-	-	-

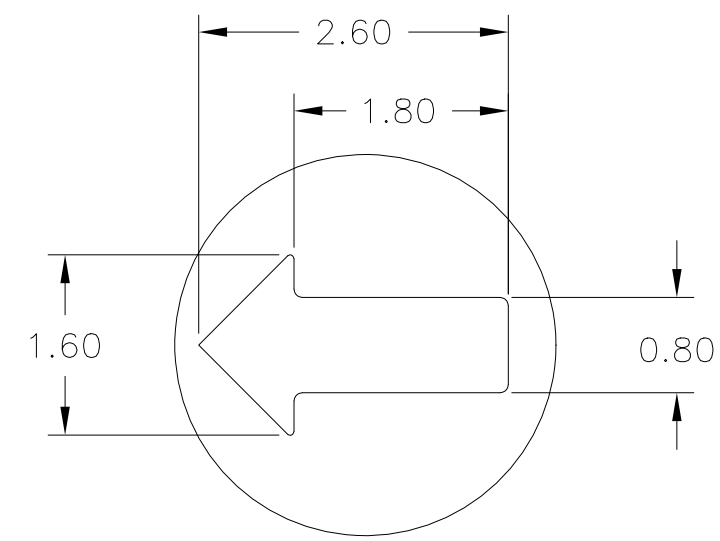
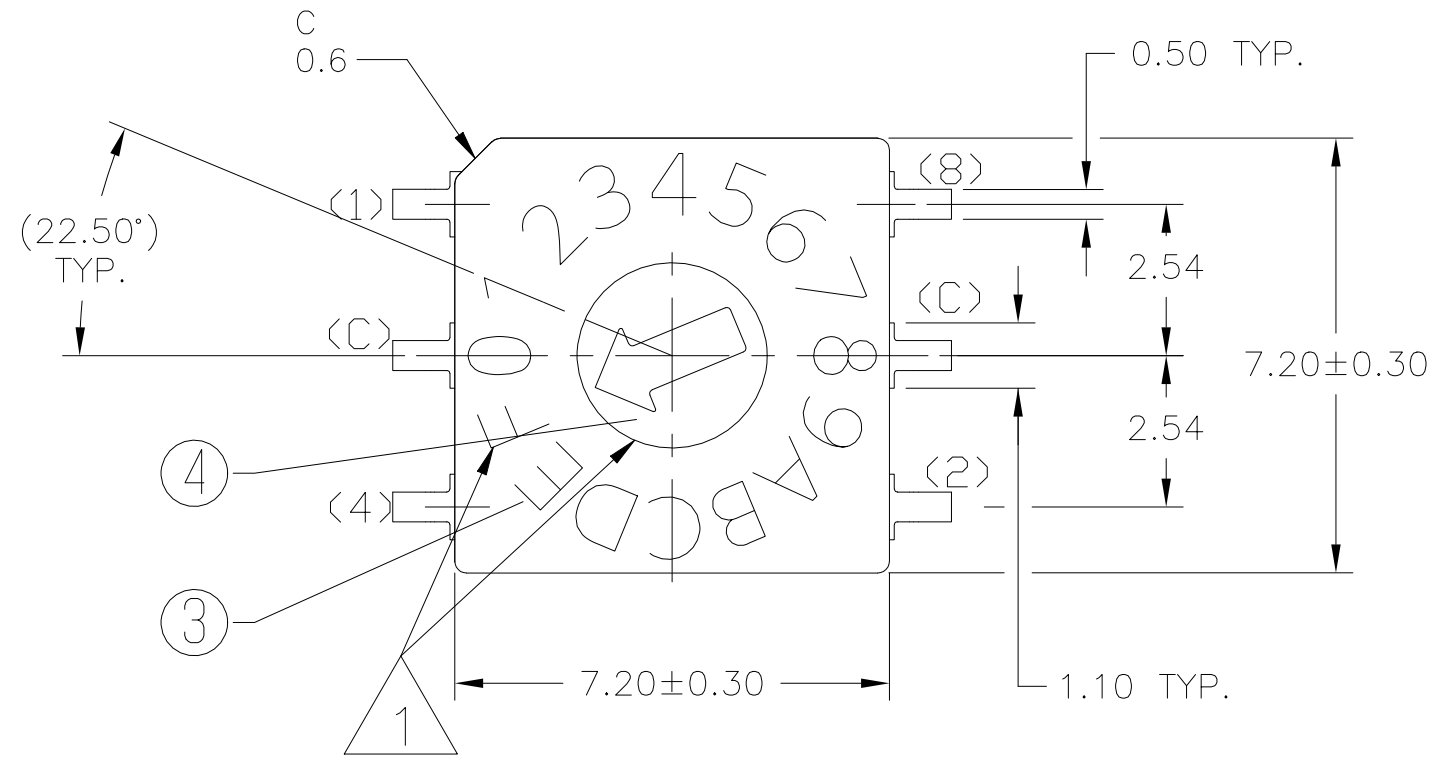

SEE SHEET 12 FOR CODE IDENTIFIER

CODE HEXADECIMAL
 (COMPLEMENT/GRAY/REAL)
 GULLWING TERMINALS
 COVER COLOR BLACK
 PRINT MARKING
 16 POSITION

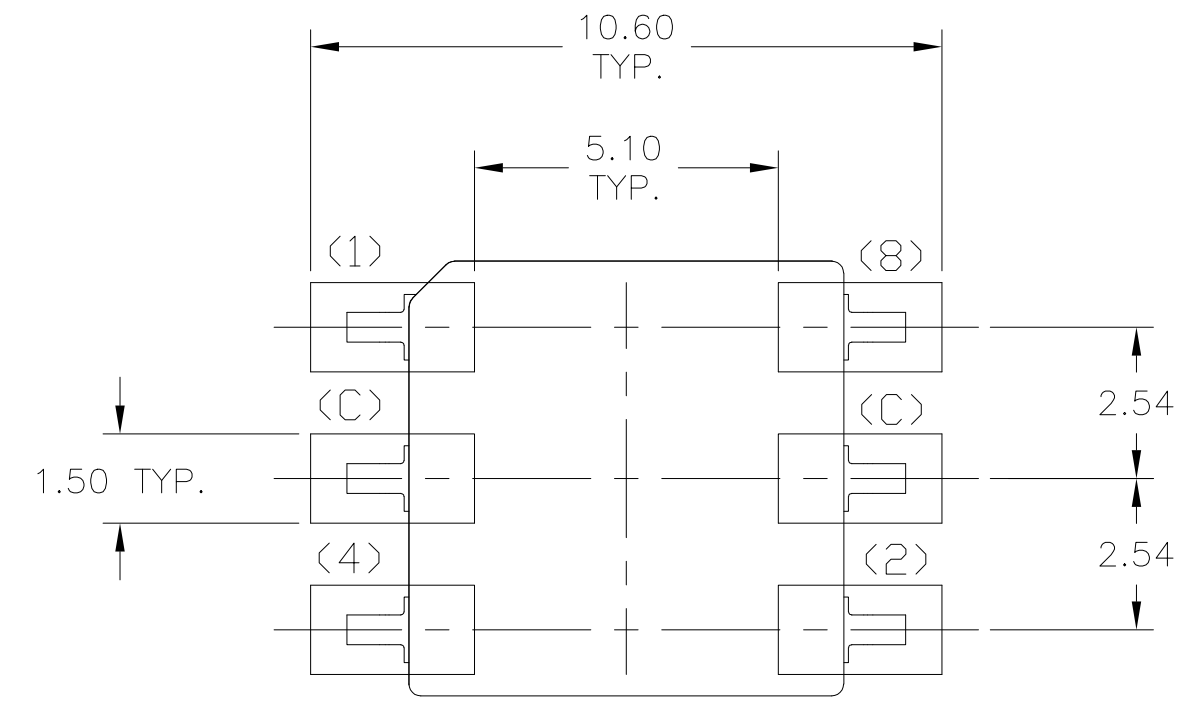
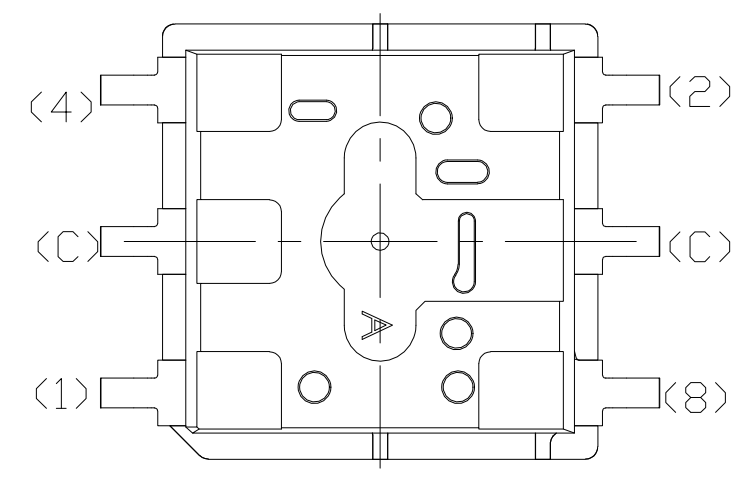
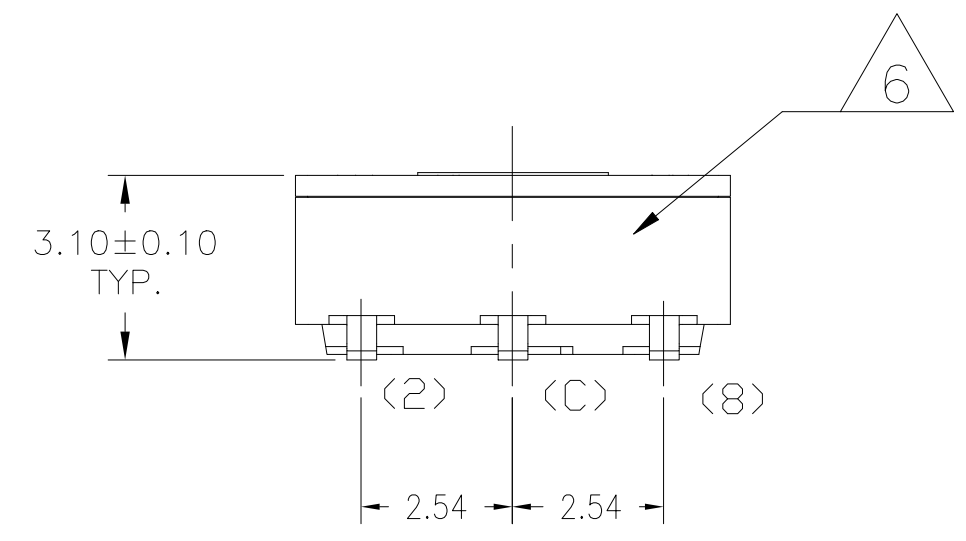
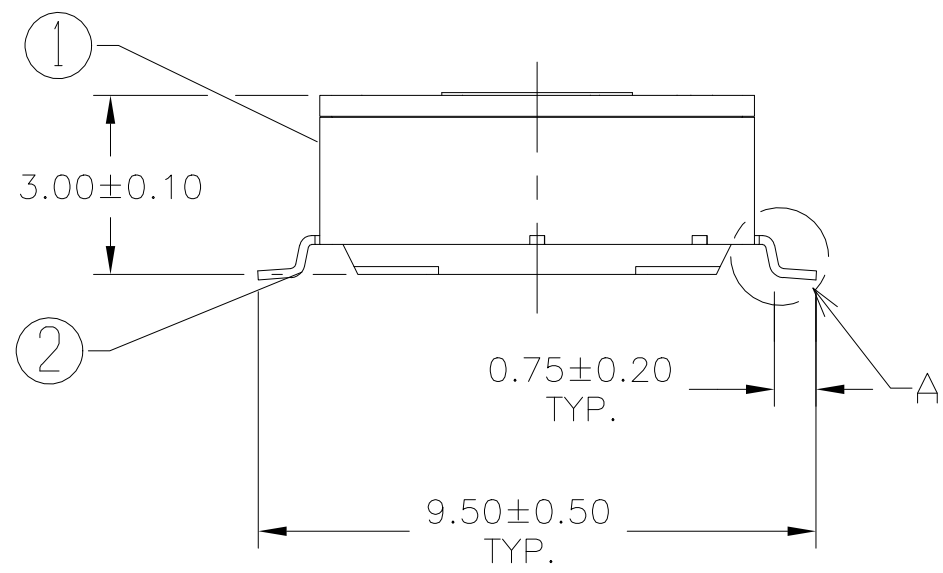

PCB Layout

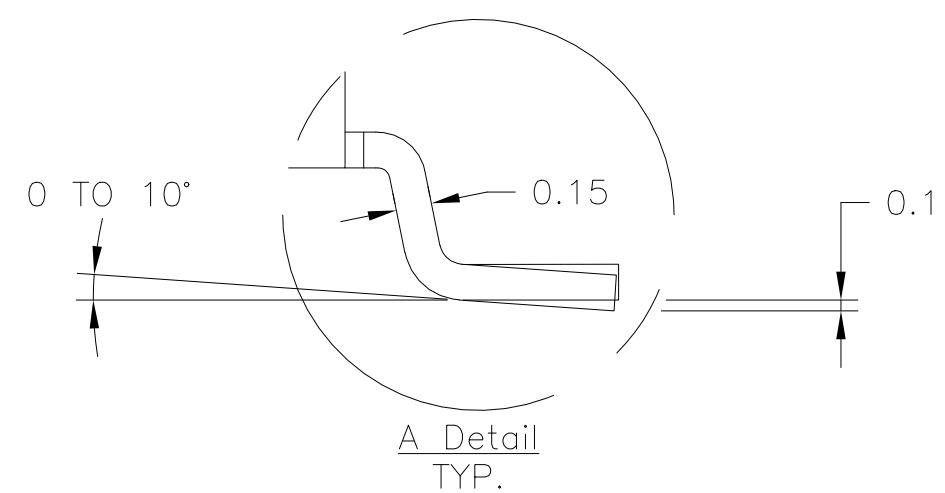
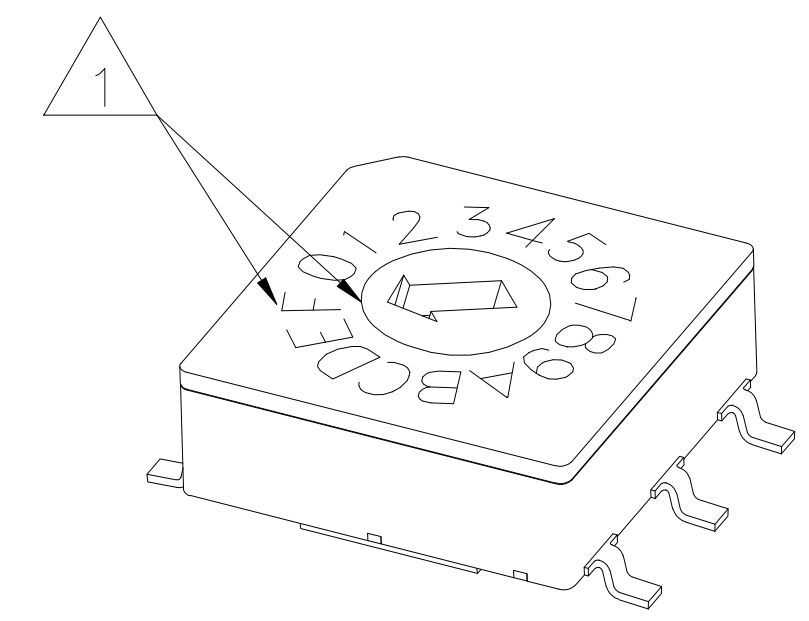

A Detail TYP.

PRELIMINARY

THIS DRAWING IS A CONTROLLED DOCUMENT.		DWN 19JUL2022 SATHISH KUMAR_G	TE Connectivity																			
DIMENSIONS: mm		CHK 19JUL2022 ALEXANDER, SHARPE																				
TOLERANCES UNLESS OTHERWISE SPECIFIED: ±0.15		APVD 19JUL2022 ALEXANDER, SHARPE	NAME MRSS, MINIATURE ROTARY SWITCH SERIES, VERTICAL, 2.54 BLACK, PRINT MARKING																			
<table border="1"> <tr><td>0 PLC</td><td>±</td><td>-</td></tr> <tr><td>1 PLC</td><td>±</td><td>-</td></tr> <tr><td>2 PLC</td><td>±</td><td>-</td></tr> <tr><td>3 PLC</td><td>±</td><td>-</td></tr> <tr><td>4 PLC</td><td>±</td><td>-</td></tr> <tr><td>ANGLES</td><td>±</td><td>-</td></tr> </table>		0 PLC	±	-	1 PLC	±	-	2 PLC	±	-	3 PLC	±	-	4 PLC	±	-	ANGLES	±	-	PRODUCT SPEC	SIZE CAGE CODE DRAWING NO	
0 PLC	±	-																				
1 PLC	±	-																				
2 PLC	±	-																				
3 PLC	±	-																				
4 PLC	±	-																				
ANGLES	±	-																				
MATERIAL		APPLICATION SPEC	RESTRICTED TO																			
FINISH		WEIGHT	A2 00779 C=2396234																			
		CUSTOMER DRAWING	SCALE 8:1	SHEET 5 of 12 REV 1																		

REVISIONS					
P	LTR	DESCRIPTION	DATE	DWN	APVD
-	-	SEE SHEET 1	-	-	-

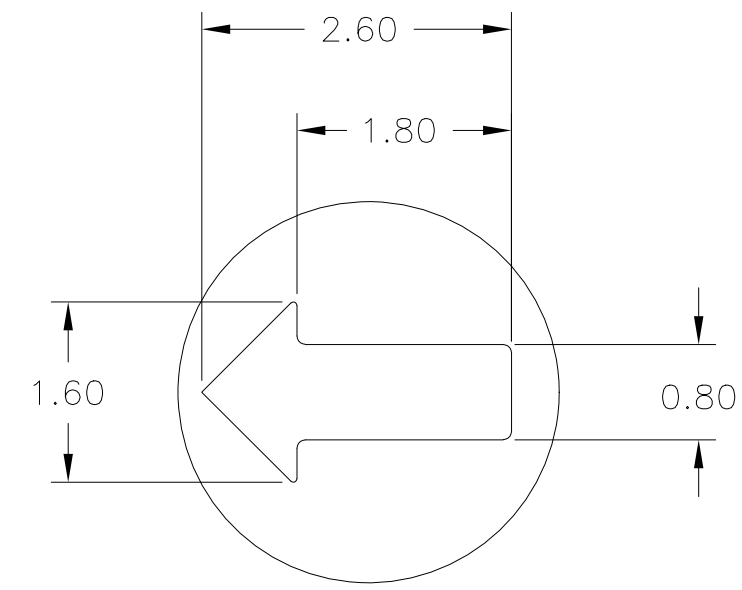
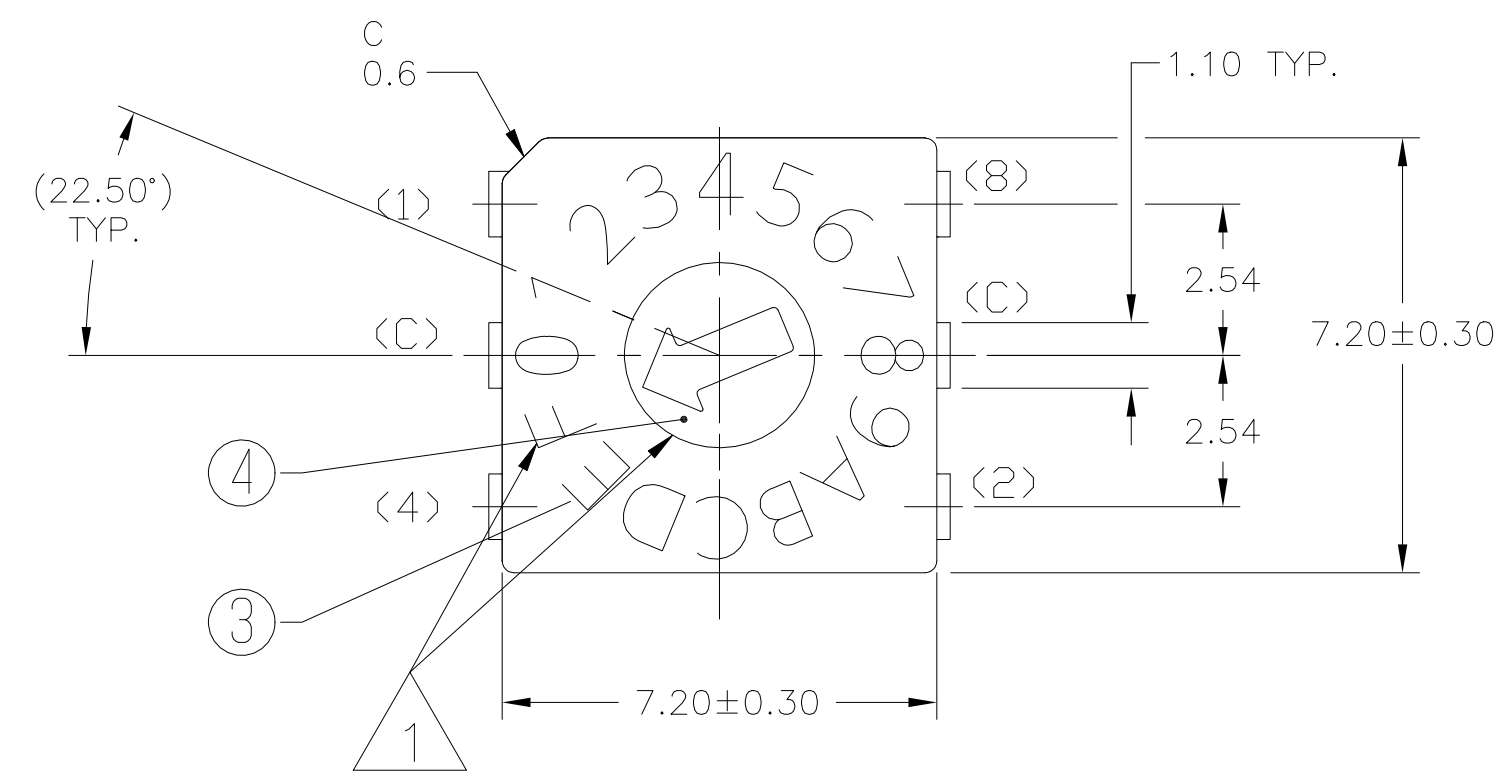

SEE SHEET 12 FOR CODE IDENTIFIER

CODE HEXADECIMAL
(COMPLEMENT/GRAY/REAL)
THROUGH-HOLE TERMINALS
COVER COLOR BLACK
PRINT MARKING
16 POSITIONS

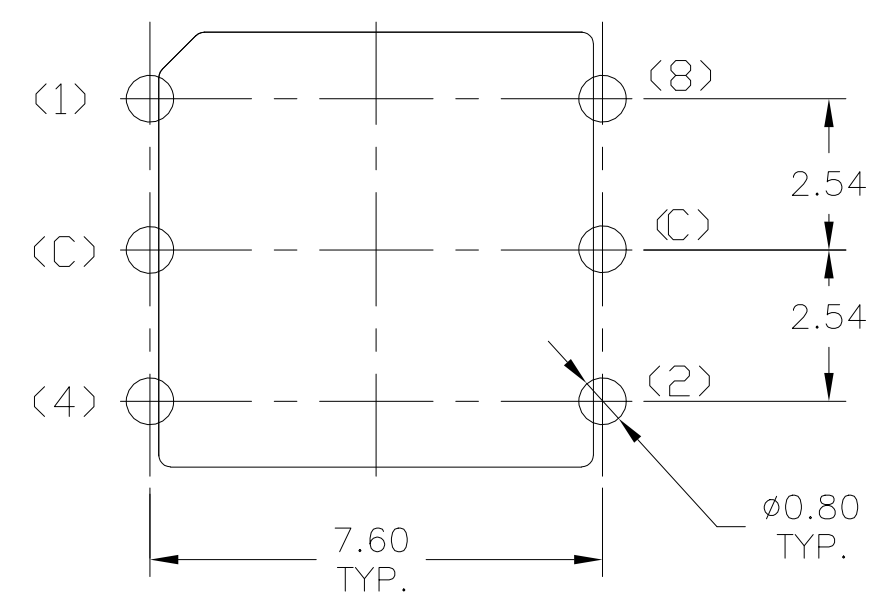
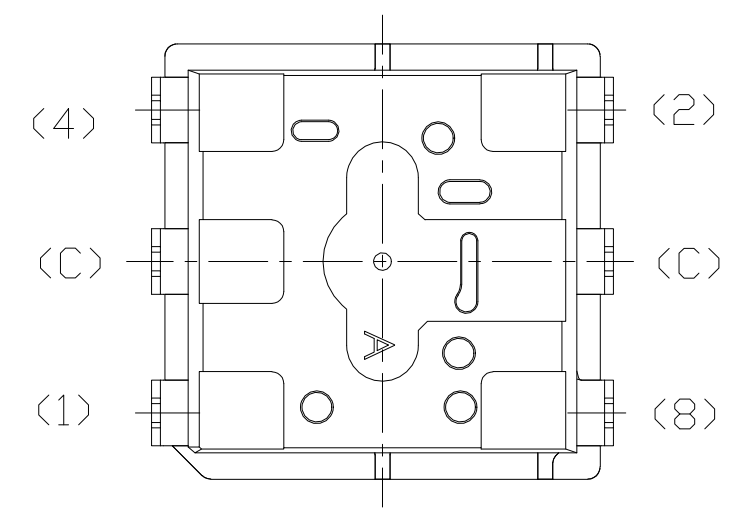
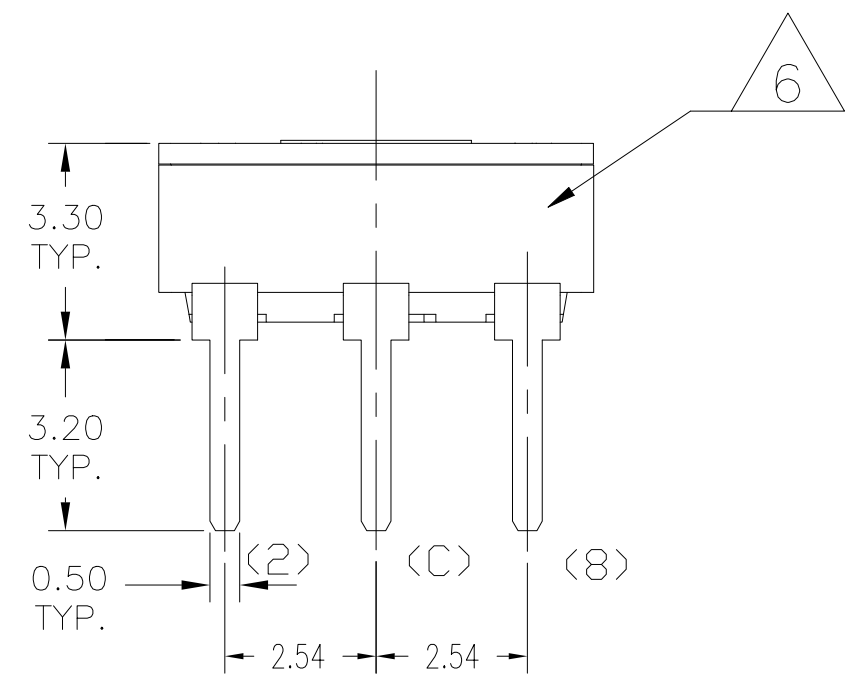
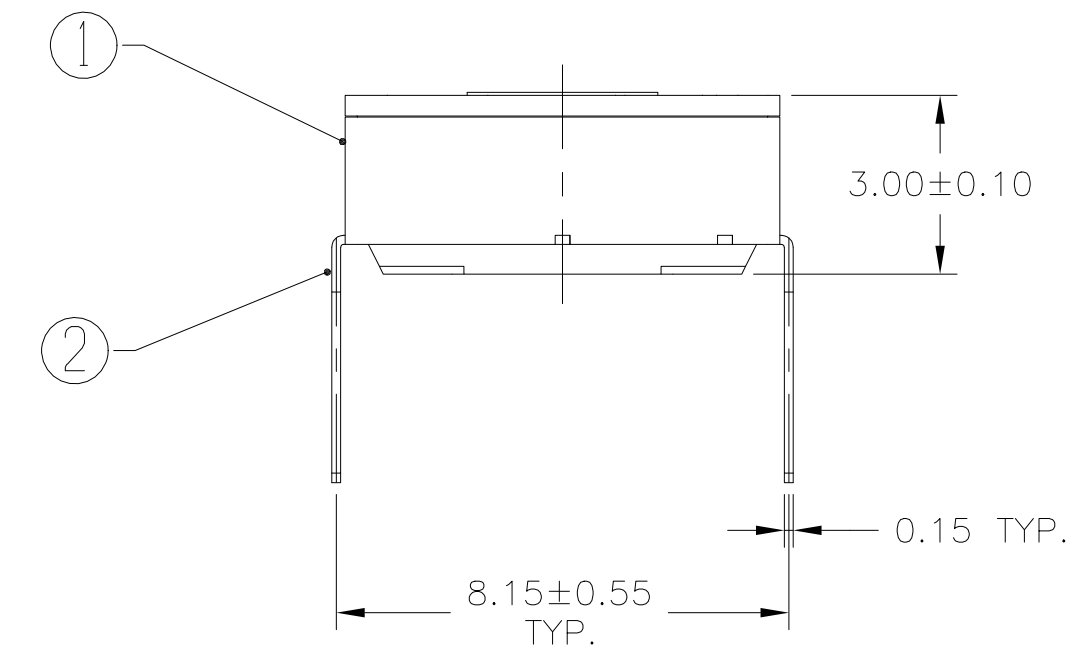

PCB Layout

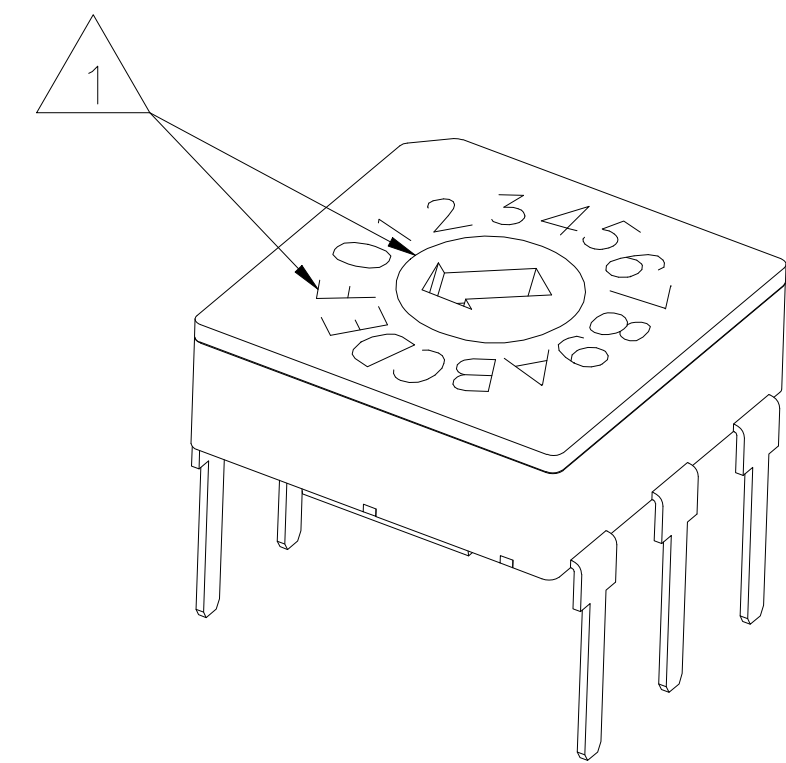

PRELIMINARY

THIS DRAWING IS A CONTROLLED DOCUMENT.		DWN 19JUL2022 SATHISH KUMAR_G	TE Connectivity																			
DIMENSIONS: mm		CHK 19JUL2022 ALEXANDER, SHARPE																				
TOLERANCES UNLESS OTHERWISE SPECIFIED: ±0.15		APVD 19JUL2022 ALEXANDER, SHARPE	NAME MRSS, MINIATURE ROTARY SWITCH SERIES, VERTICAL, 2.54 BLACK, PRINT MARKING																			
<table border="1"> <tr><td>0 PLC</td><td>±</td><td>=</td></tr> <tr><td>1 PLC</td><td>±</td><td>=</td></tr> <tr><td>2 PLC</td><td>±</td><td>=</td></tr> <tr><td>3 PLC</td><td>±</td><td>=</td></tr> <tr><td>4 PLC</td><td>±</td><td>=</td></tr> <tr><td>ANGLES</td><td>±</td><td>=</td></tr> </table>		0 PLC	±	=	1 PLC	±	=	2 PLC	±	=	3 PLC	±	=	4 PLC	±	=	ANGLES	±	=	PRODUCT SPEC	RESTRICTED TO	
0 PLC	±	=																				
1 PLC	±	=																				
2 PLC	±	=																				
3 PLC	±	=																				
4 PLC	±	=																				
ANGLES	±	=																				
MATERIAL		APPLICATION SPEC	SIZE A2	CAGE CODE 00779																		
FINISH		WEIGHT	DRAWING NO. C=2396234	SCALE 8:1																		
		CUSTOMER DRAWING	SHEET 6 OF 12	REV 1																		

REVISIONS					
P	LTR	DESCRIPTION	DATE	DWN	APVD
-	-	SEE SHEET 1	-	-	-

10 POSITION, BINARY COMPLEMENT										
POS	0	1	2	3	4	5	6	7	8	9
C	X	X	X	X	X	X	X	X	X	X
1	X		X		X		X		X	
2	X	X			X	X			X	X
4	X	X	X	X					X	X
8	X	X	X	X	X	X	X	X		

16 POSITION, HEXADECIMAL COMPLEMENT																
POS	0	1	2	3	4	5	6	7	8	9	A	B	C	D	E	F
C	X	X	X	X	X	X	X	X	X	X	X	X	X	X	X	X
1	X			X		X			X		X		X		X	
2	X	X			X	X			X	X			X	X		
4	X	X	X	X					X	X	X	X				
8	X	X	X	X	X	X	X	X								

10 POSITION, BINARY GRAY										
POS	0	1	2	3	4	5	6	7	8	9
C	X	X	X	X	X	X	X	X	X	X
1		X	X			X	X			X
2			X	X	X	X				
4				X	X	X	X	X	X	X
8									X	X

16 POSITION, HEXADECIMAL GRAY																
POS	0	1	2	3	4	5	6	7	8	9	A	B	C	D	E	F
C	X	X	X	X	X	X	X	X	X	X	X	X	X	X	X	X
1		X	X		X	X			X	X			X	X		
2			X	X	X	X				X	X	X	X			
4				X	X	X	X	X	X	X	X					
8								X	X	X	X	X	X	X	X	X

10 POSITION, BINARY REAL										
POS	0	1	2	3	4	5	6	7	8	9
C	X	X	X	X	X	X	X	X	X	X
1		X		X		X		X		X
2			X	X		X	X			
4				X	X	X	X	X	X	X
8									X	X

16 POSITION, HEXADECIMAL REAL																
POS	0	1	2	3	4	5	6	7	8	9	A	B	C	D	E	F
C	X	X	X	X	X	X	X	X	X	X	X	X	X	X	X	X
1		X		X		X		X		X		X		X		X
2			X	X		X	X			X	X			X	X	
4				X	X	X	X				X	X	X	X	X	X
8								X	X	X	X	X	X	X	X	X

LEGEND
TE SMART PART NUMBER

ACTUATOR ORIENTATION
V=VERTICAL
H=HORIZONTAL

CONFIGURATION/PITCH/COVER COLOR OR BRACKET/MARKING:
0=DIP/2.54/GRAY/LASER, SEE TE DRAWING 2396233
1=DIP/2.54/BLACK/PRINTED
4=SIP/1.27/STAINLESS STEEL/LASER, SEE TE DRAWING 2396236

ACTUATOR TYPE
D=SCREWDRIVER SLOT, FLUSH

CODE
C=COMPLEMENT
G=GRAY
R=REAL

POSITIONS
10
16

TERMINATION TYPE
SM =SURFACE MOUNT
TH =THROUGH-HOLE

SOLDER TERMINAL CONFIGURATION:
J = J-LEAD
GW=GULLWING
BLANK=THROUGH-HOLE

PACKAGING:
T = TUBE
TR=TAPE AND REEL

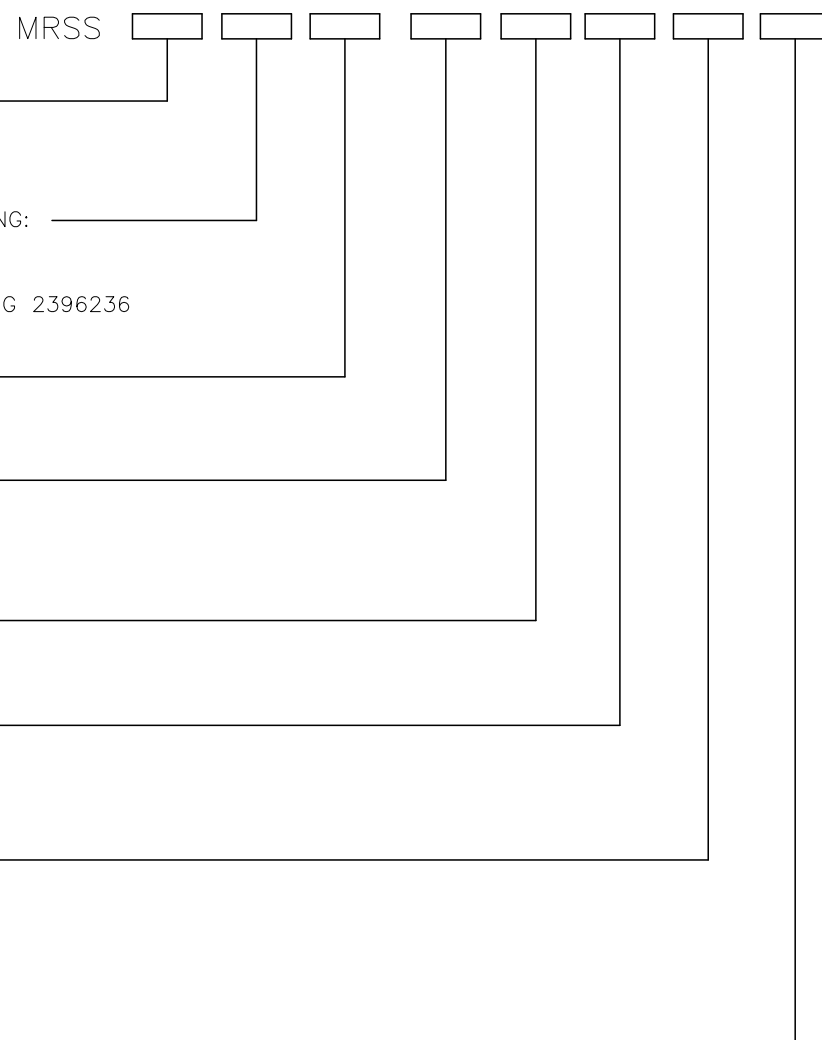

ACTUATION	ACTUATOR POSITION	CODE	POSITIONS	SOLDER TERMINAL CONFIGURATION	PACKAGING	TE SMART PART NUMBER	TE PART NUMBER
SCREWDRIVER SLOT, FLUSH	O	HEXADECIMAL REAL	16	THROUGH-HOLE	TUBE	MRSSV1DR16THT	3-2396234-0
				GULLWING	TUBE	MRSSV1DR16SMGWT	2-2396234-9
				J-LEAD	TAPE & REEL	MRSSV1DR16SMGWTR	2-2396234-8
		BINARY REAL	10	THROUGH-HOLE	TUBE	MRSSV1DR10THT	2-2396234-5
				GULLWING	TUBE	MRSSV1DR10SMGWT	2-2396234-4
				J-LEAD	TAPE & REEL	MRSSV1DR10SMGWTR	2-2396234-3
	HEXADECIMAL GRAY	16	THROUGH-HOLE	TUBE	MRSSV1DG16THT	2-2396234-0	
			GULLWING	TUBE	MRSSV1DG16SMGWT	1-2396234-9	
			J-LEAD	TAPE & REEL	MRSSV1DG16SMGWTR	1-2396234-8	
	BINARY GRAY	10	THROUGH-HOLE	TUBE	MRSSV1DG10THT	1-2396234-5	
			GULLWING	TUBE	MRSSV1DG10SMGWT	1-2396234-4	
			J-LEAD	TAPE & REEL	MRSSV1DG10SMGWTR	1-2396234-3	
F	HEXADECIMAL COMPLEMENT	16	THROUGH-HOLE	TUBE	MRSSV1DC16THT	1-2396234-0	
			GULLWING	TUBE	MRSSV1DC16SMGWT	2396234-9	
			J-LEAD	TAPE & REEL	MRSSV1DC16SMGWTR	2396234-8	
7	BINARY COMPLEMENT	10	THROUGH-HOLE	TUBE	MRSSV1DC10THT	2396234-5	
			GULLWING	TUBE	MRSSV1DC10SMGWT	2396234-4	
			J-LEAD	TAPE & REEL	MRSSV1DC10SMGWTR	2396234-3	
				THROUGH-HOLE	TUBE	MRSSV1DC10SMJTR	2396234-2
				J-LEAD	TAPE & REEL	MRSSV1DC10SMJTR	2396234-1

PRELIMINARY

THIS DRAWING IS A CONTROLLED DOCUMENT.

DIMENSIONS: mm

TOLERANCES UNLESS OTHERWISE SPECIFIED:

0 PLC ± -
1 PLC ± -
2 PLC ± -
3 PLC ± -
4 PLC ± -
ANGLES ± -

MATERIAL - FINISH -

DWN 19JUL2022 SATHISH KUMAR G
CHK 19JUL2022 ALEXANDER, SHARPE
APVD 19JUL2022 ALEXANDER, SHARPE

NAME MRSS, MINIATURE ROTARY SWITCH SERIES, VERTICAL, 2.54 BLACK, PRINT MARKING

SIZE A2 CAGE CODE 00779 DRAWING NO. C=2396234 RESTRICTED TO -

SCALE 8:1 SHEET 7 OF 12 REV 1

CUSTOMER DRAWING

NOTES:

1. SEE TABLE, SHEET 7 OF 12 FOR ACTUATOR POSITION WHEN DELIVERED, THE SWITCH SHALL REMAIN IN THIS POSITION DURING MOUNTING/TERMINATION TO AND CLEANING OF THE P.C.BOARD.
2. COMPLIANCE: THE CURRENT STATEMENT OF COMPLIANCE IS AVAILABLE AT TE.COM
3. IF THE SWITCH IS NOT ACTUATED FOR AN EXTENDED PERIOD OF TIME, SIX MONTHS, IT MAY REQUIRE ACTUATING TO RESTORE SWITCH FUNCTION.
4. MSL 1 PER JIS C61760-4:2016 AND IEC 61760-4:2015
5. TAPE AND REEL PER EIA 481 TAPE WIDTH 16MM, PITCH 16MM, SEE SHEET 9 OF 12.
6. TE PART NUMBER AND DATE CODE

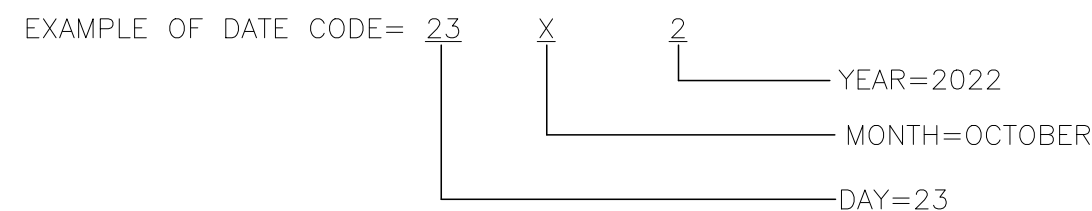

- MONTH=
- 1 = JANUARY
 - 2 = FEBRUARY
 - 3 = MARCH
 - 4 = APRIL
 - 5 = MAY
 - 6 = JUNE
 - 7 = JULY
 - 8 = AUGUST
 - 9 = SEPTEMBER
 - X = OCTOBER
 - Y = NOVEMBER
 - Z = DECEMBER

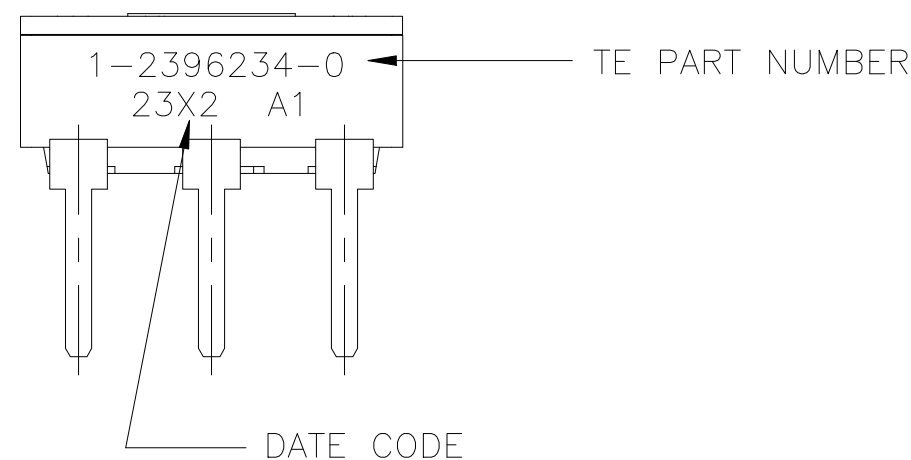

SPECIFICATIONS:

OPERATING CURRENT, 0.4VA @ 20VAC OR DC, MAXIMUM.
 MINIMUM SWITCHING CURRENT, 0.1µA @ 1mV MINIMUM.
 MAXIMUM SWITCHING CURRENT(DURING MAKE OR BREAK), 10mA@5VDC
 NONE SWITCHING CURRENT 100mA@50VDC MAXIMUM
 INITIAL CONTACT RESISTANCE, 100 MILLIOHMS MAX. @ 2V DC 10MILLIAMP
 CONTACT RESISTANCE AFTER TEST AND PCB TERMINATION, 300 MILLIOHMS MAX.
 INSULATION RESISTANCE, 1,000 MEGOHMS MIN. @ 250 VDC
 DIELECTRIC STRENGTH, 250 VAC , 1 MINUTE
 ELECTRICAL LIFE, 10,000 ACTUATIONS MIN. @ 5V DC 10MILLIAMP
 MECHANICAL LIFE, 10,000 ACTUATIONS MIN. AT NO LOAD
 INITIAL ACTUATION TORQUE, 2.0 TO 19.6mN.m.
 TEMPERATURE RANGE, -40 TO +85°C

SOLDERING CONDITIONS

MANUAL	TEMPERATURE OF SOLDER IRON TIP: 320°C MAX. FOR 4±1 SECONDS	PRINTED CIRCUIT BOARD THICKNESS 1.6
WAVE (FOR THROUGH-HOLE)	PREHEAT 100 TO 105°C FOR 30±5 SECONDS	
	SOLDER TEMPERATURE 265°C±3°C FOR 8±2 SECONDS	
REFLOW (FOR GULLWING AND J-LEAD)	PREHEAT 160 TO 190°C FOR 90 TO 120 SECONDS	
	REFLOW TEMPERATURE 225°C (SWITCH SURFACE) FOR 20 TO 60 SECONDS	
	PEAK TEMPERATURE 255 TO 265°C (SWITCH SURFACE) MAXIMUM NUMBER OF EXPOSURES TO REFLOW PROCESS IS 2	

REFLOW SOLDER PROFILE FOR J-LEAD AND GULLWING TERMINALS

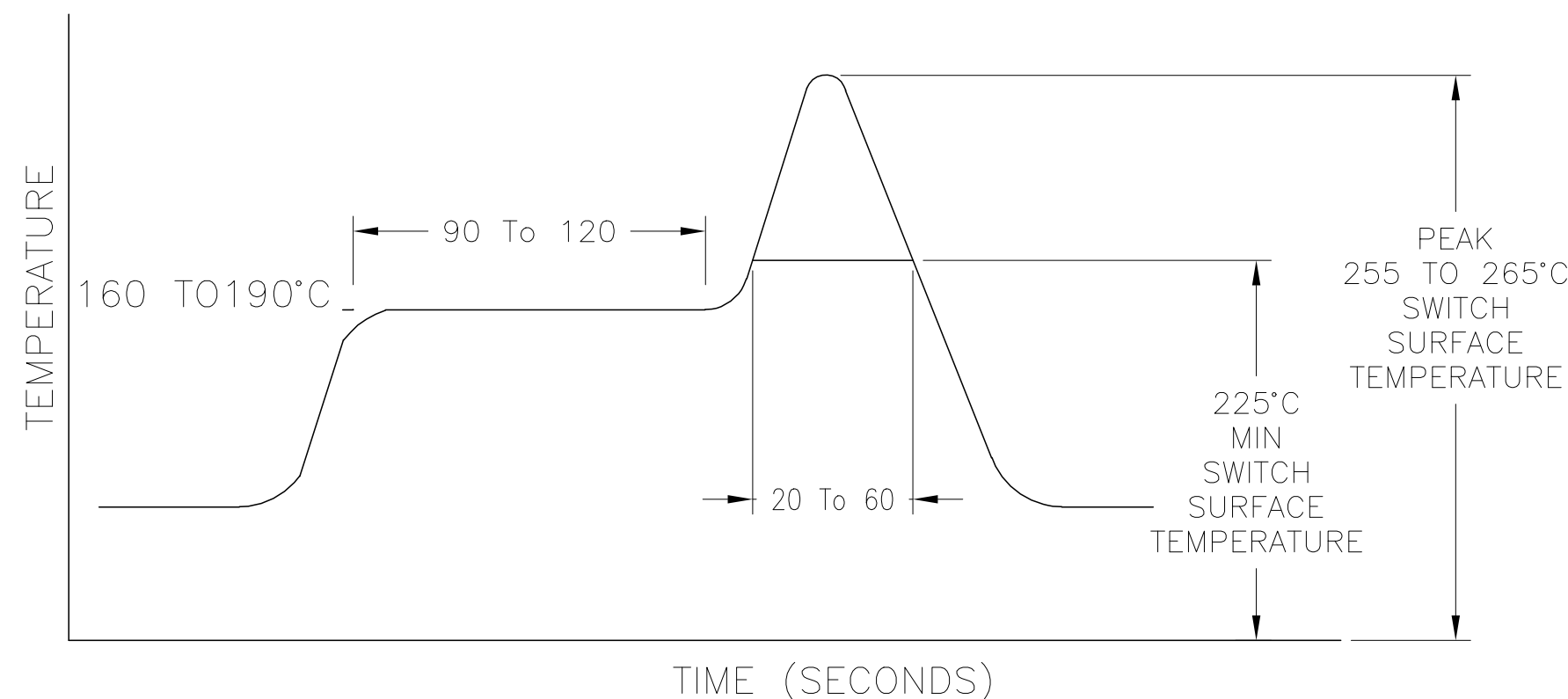

1	N/A	STAINLESS STEEL	PLATE	7
1	GOLD OVER NICKEL	COPPER ALLOY	CONTACT	6
1	N/A	FPM (FLUOROCARBON)	O-RING	5
1	WHITE	LCP	ACTUATOR	4
1	BLACK	POLYPHENYLENE SULFIDE	COVER	3
6	GOLD OVER NICKEL	BRASS	TERMINAL	2
1	BLACK	POLYPHENYLENE SULFIDE	CASE	1
QTY	FINISH/COLOR	MATERIAL	COMPONENT	ITEM

THIS DRAWING IS A CONTROLLED DOCUMENT.

DWN 19JUL2022 SATHISH KUMAR G
 CHK 19JUL2022 ALEXANDER, SHARPE
 APVD 19JUL2022 ALEXANDER, SHARPE

TE Connectivity

NAME: MRSS, MINIATURE ROTARY SWITCH SERIES, VERTICAL, 2.54 BLACK, PRINT MARKING

SIZE: A2 CAGE CODE: 00779 DRAWING NO: 2396234 RESTRICTED TO: -

SCALE: 8:1 SHEET: 8 of 12 REV: 1

CUSTOMER DRAWING

PRELIMINARY

4

3

2

1

© 2022 TE Connectivity. All Rights Reserved.

PACKAGING SPECIFICATIONS
TAPE AND REEL FOR SMT, J-LEAD TERMINALS

REVISIONS					
P	LTR	DESCRIPTION	DATE	DWN	APVD
-	-	SEE SHEET 1	-	-	-

SECTION A-A
MAX R0.3

SECTION B-B
MAX 5°
MAX R0.3

PULLOUT DIRECTION

120° TYP.
R120
40°
2
2
TYP.
PULLOUT DIRECTION
16.4
16.4
1000 PCS PER REEL

TAPE AND REEL FOR SMT, GULLWING TERMINALS

SECTION C-C
MAX 5°
MAX R0.3

PULLOUT DIRECTION

CARRIER TAPE
COVER TAPE

SECTION D-D
MAX 5°
MAX R0.3

MOISTURE BARRIER BAG
DESICCANT
CARD BOARD BOX
2000 PCS TOTAL (2 REELS) PER BOX

PRELIMINARY

THIS DRAWING IS A CONTROLLED DOCUMENT.		DWN SATHISH KUMAR G 19JUL2022																				
DIMENSIONS: mm		CHK ALEXANDER, SHARPE 19JUL2022																				
TOLERANCES UNLESS OTHERWISE SPECIFIED:		APVD ALEXANDER, SHARPE 19JUL2022	NAME MRSS, MINIATURE ROTARY SWITCH SERIES, VERTICAL, 2.54 BLACK, PRINT MARKING																			
<table border="1"> <tr><td>0 PLC</td><td>±</td><td>=</td></tr> <tr><td>1 PLC</td><td>±</td><td>=</td></tr> <tr><td>2 PLC</td><td>±</td><td>=</td></tr> <tr><td>3 PLC</td><td>±</td><td>=</td></tr> <tr><td>4 PLC</td><td>±</td><td>=</td></tr> <tr><td>ANGLES</td><td>±</td><td>=</td></tr> </table>		0 PLC	±	=	1 PLC	±	=	2 PLC	±	=	3 PLC	±	=	4 PLC	±	=	ANGLES	±	=	PRODUCT SPEC APPLICATION SPEC	RESTRICTED TO	
0 PLC	±	=																				
1 PLC	±	=																				
2 PLC	±	=																				
3 PLC	±	=																				
4 PLC	±	=																				
ANGLES	±	=																				
MATERIAL -		FINISH -	WEIGHT -	SCALE 8:1																		
		CUSTOMER DRAWING	SIZE A2	SHEET 9 of 12																		
			DRAWING NO C=2396234	REV 1																		

1471-9 (1/15)

2396234

A

PACKAGING SPECIFICATIONS TUBE FOR SMT, J-LEAD AND GULLWING TERMINALS

REVISIONS					
P	LTR	DESCRIPTION	DATE	DWN	APVD
-	-	SEE SHEET 1	-	-	-

TE PART NUMBER PER TABLE, SHEET 7

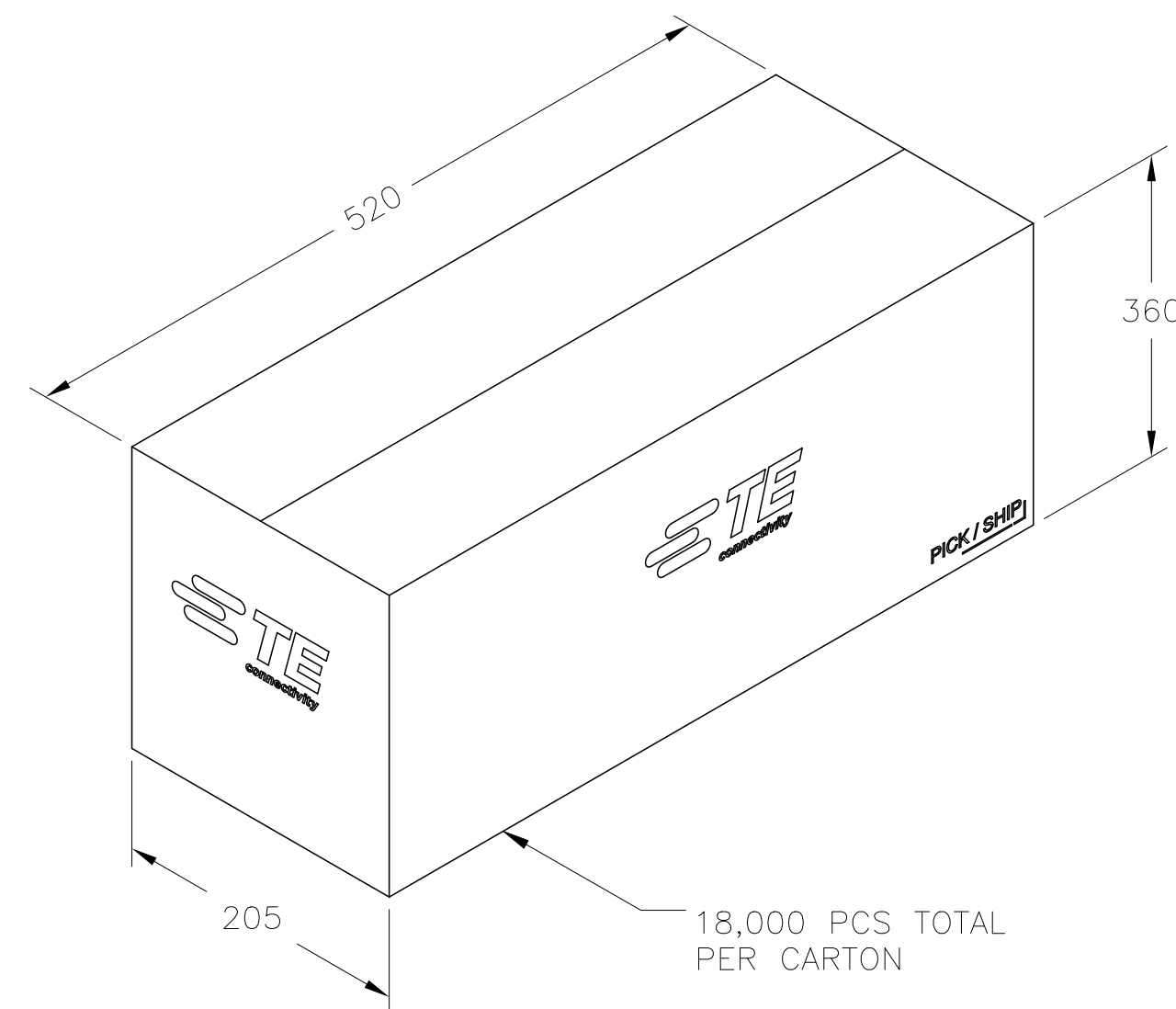
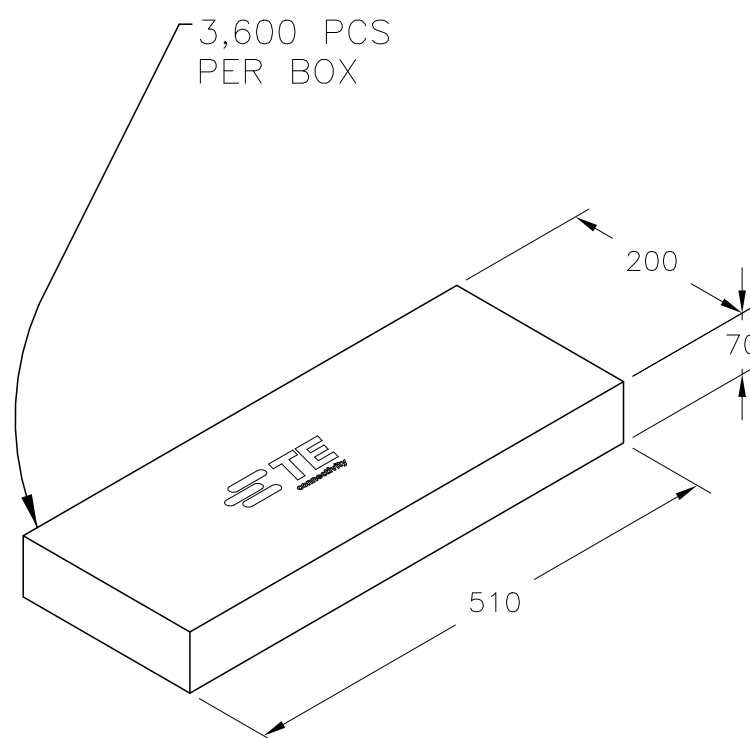
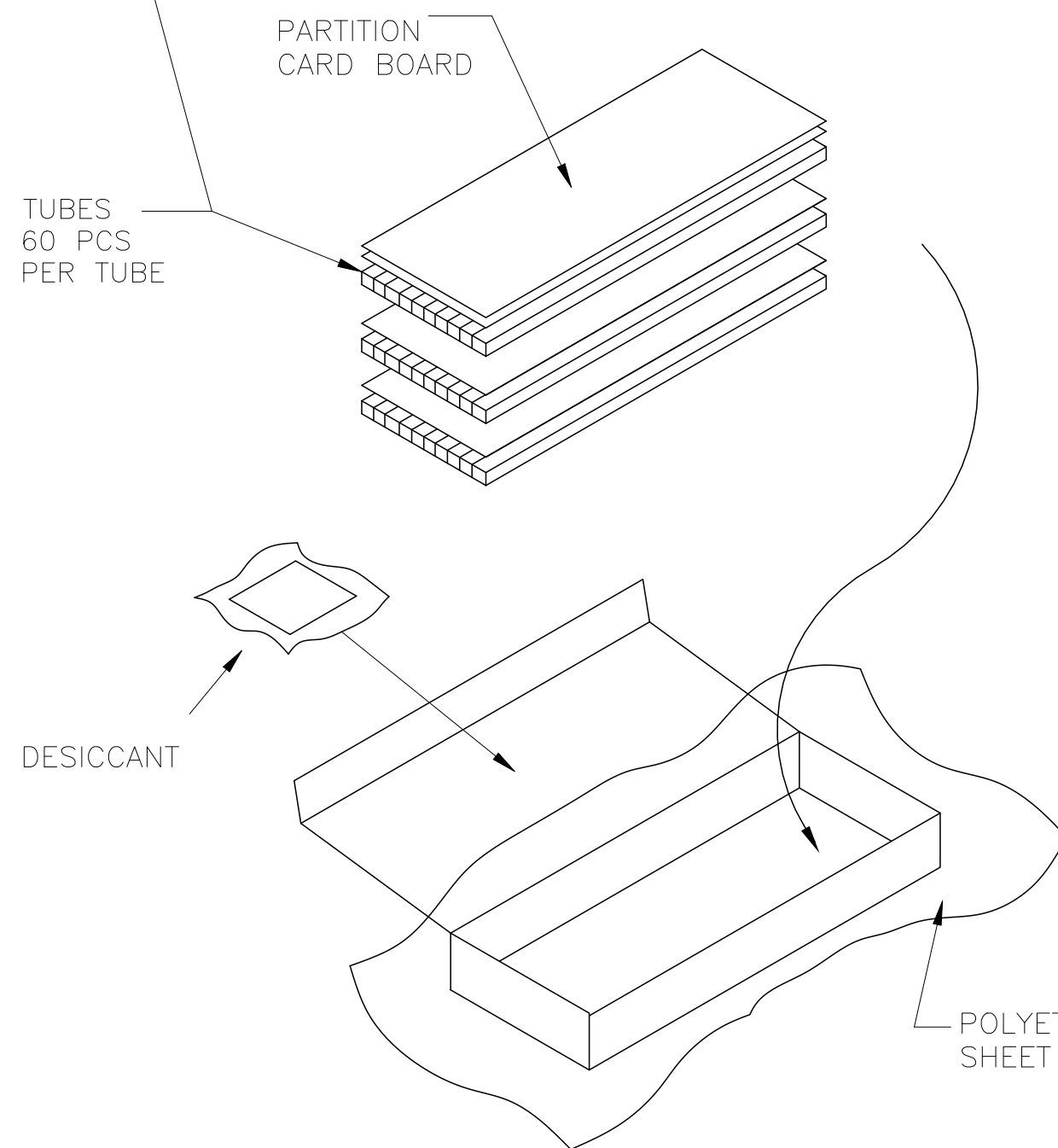
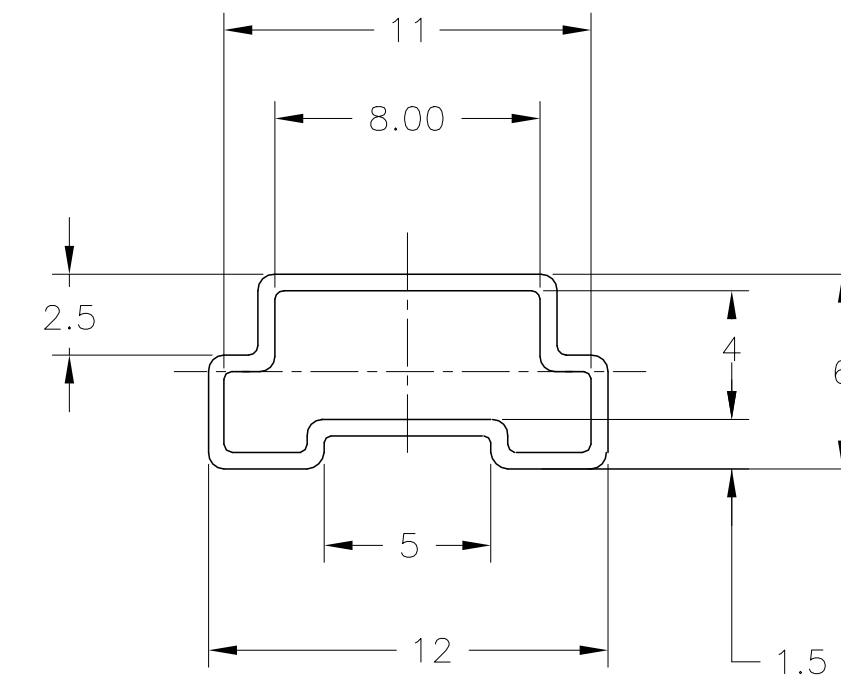
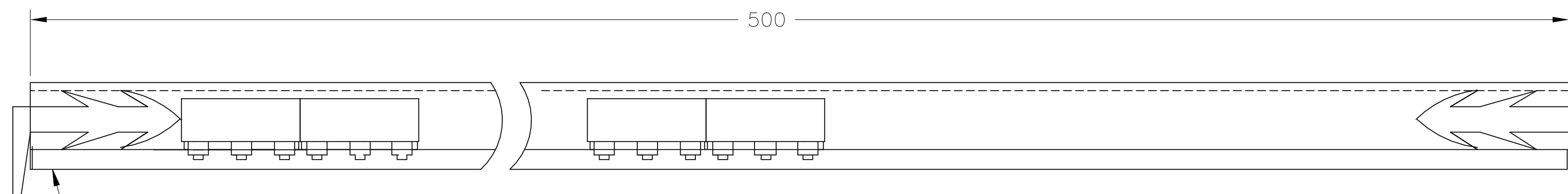
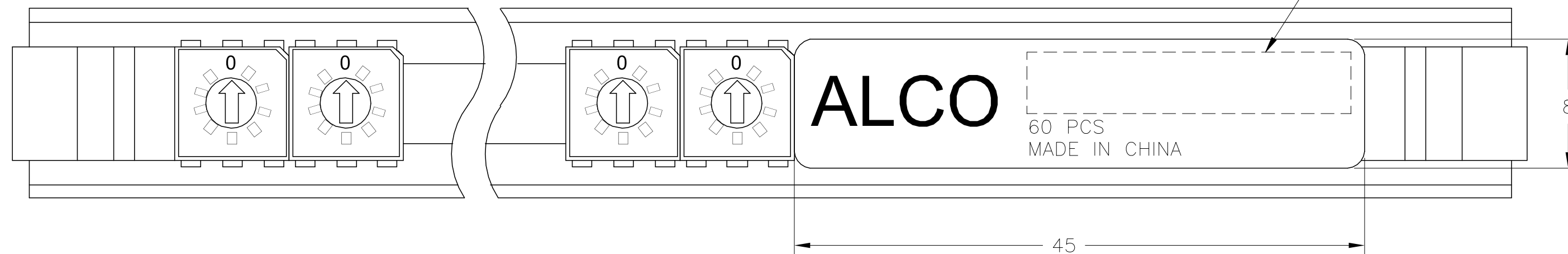

PRELIMINARY

THIS DRAWING IS A CONTROLLED DOCUMENT.		DWN 19JUL2022 SATHISH KUMAR_G	STE TE Connectivity																				
DIMENSIONS: mm		CHK 19JUL2022 ALEXANDER, SHARPE																					
TOLERANCES UNLESS OTHERWISE SPECIFIED:		APVD 19JUL2022 ALEXANDER, SHARPE	NAME MRSS, MINIATURE ROTARY SWITCH SERIES, VERTICAL, 2.54 BLACK, PRINT MARKING																				
<table border="1"> <tr><td>0 PLC</td><td>±</td><td>=</td></tr> <tr><td>1 PLC</td><td>±</td><td>=</td></tr> <tr><td>2 PLC</td><td>±</td><td>=</td></tr> <tr><td>3 PLC</td><td>±</td><td>=</td></tr> <tr><td>4 PLC</td><td>±</td><td>=</td></tr> <tr><td>ANGLES</td><td>±</td><td>=</td></tr> </table>		0 PLC	±	=	1 PLC	±	=	2 PLC	±	=	3 PLC	±	=	4 PLC	±	=	ANGLES	±	=	PRODUCT SPEC	SIZE CAGE CODE DRAWING NO RESTRICTED TO		
0 PLC	±	=																					
1 PLC	±	=																					
2 PLC	±	=																					
3 PLC	±	=																					
4 PLC	±	=																					
ANGLES	±	=																					
MATERIAL		APPLICATION SPEC	A2 00779 C=2396234																				
FINISH		WEIGHT	CUSTOMER DRAWING SCALE 8:1 SHEET 10 OF 12 REV 1																				

PACKAGING SPECIFICATIONS TUBE FOR THROUGH HOLE TERMINALS

REVISIONS					
P	LTR	DESCRIPTION	DATE	DWN	APVD
-	-	SEE SHEET 1	-	-	-

TE PART NUMBER PER TABLE, SHEET 7

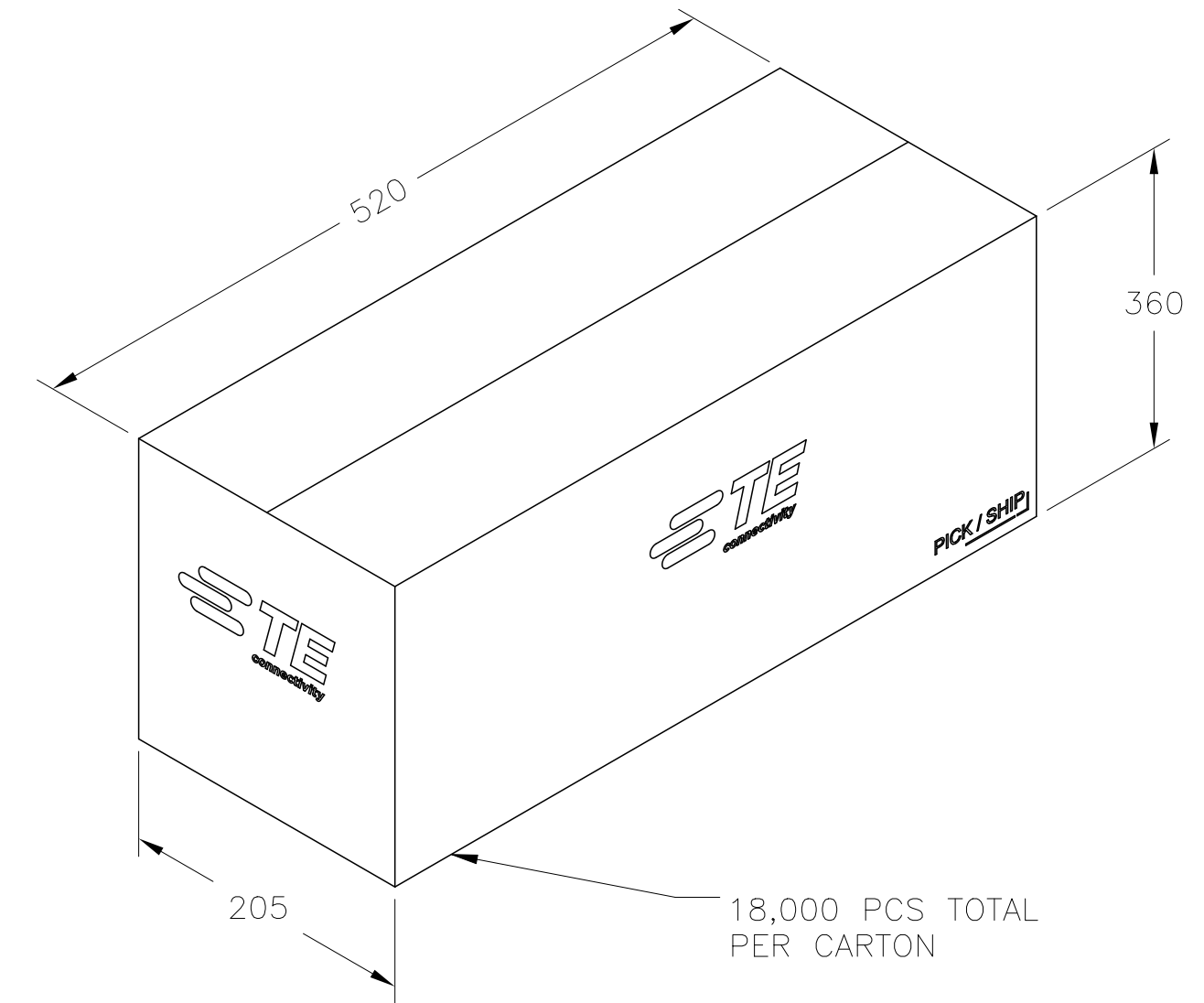
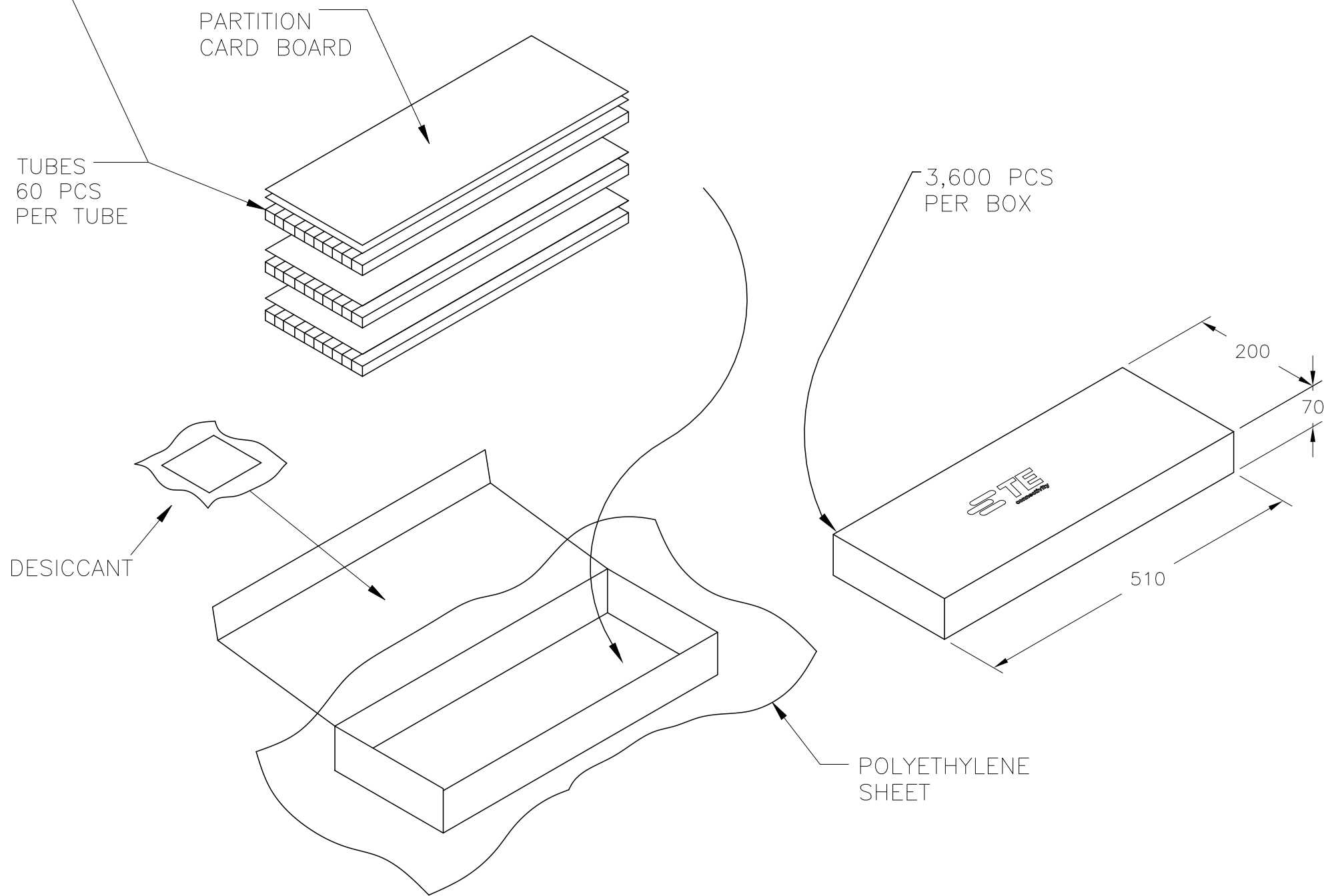
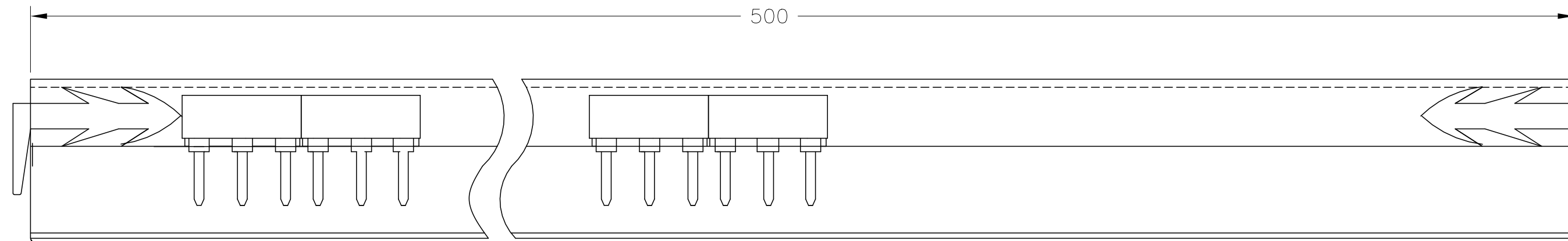
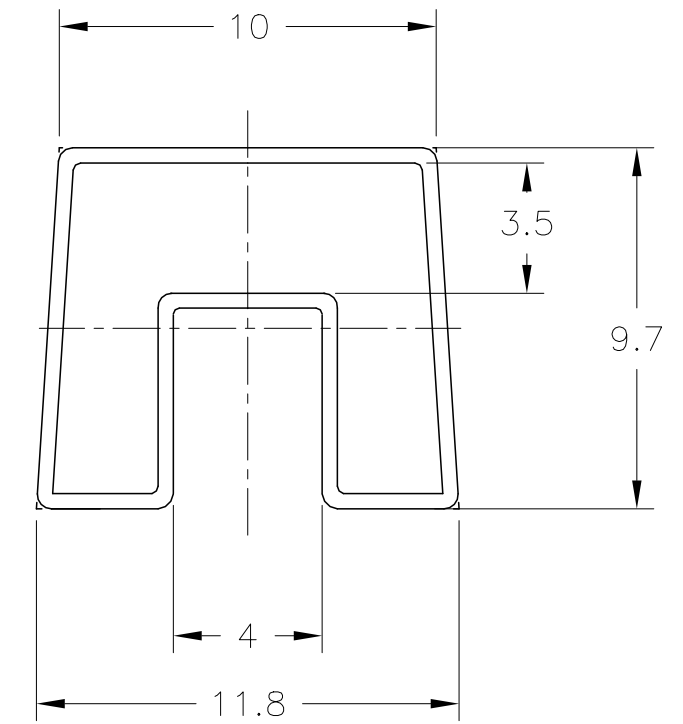
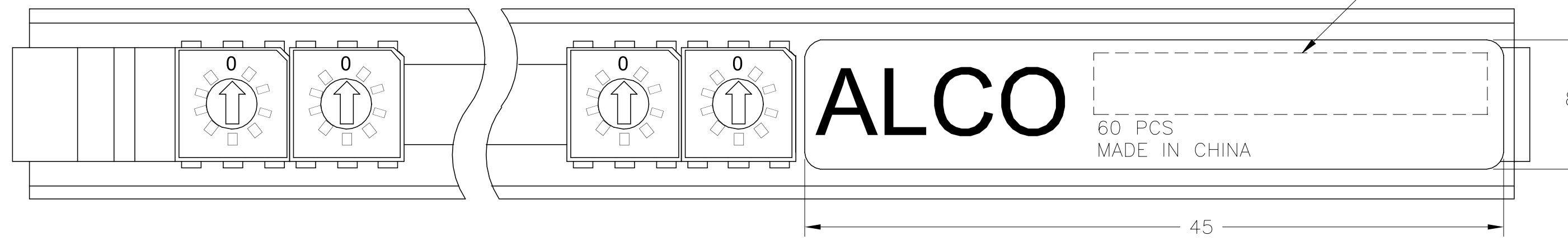

PRELIMINARY

THIS DRAWING IS A CONTROLLED DOCUMENT.		DWN 19JUL2022 SATHISH KUMAR_G	STE TE Connectivity																									
DIMENSIONS: mm		CHK 19JUL2022 ALEXANDER, SHARPE																										
TOLERANCES UNLESS OTHERWISE SPECIFIED:		APVD 19JUL2022 ALEXANDER, SHARPE	NAME MRSS, MINIATURE ROTARY SWITCH SERIES, VERTICAL, 2.54 BLACK, PRINT MARKING																									
<table border="1"> <tr><td>0 PLC</td><td>±</td><td>-</td></tr> <tr><td>1 PLC</td><td>±</td><td>-</td></tr> <tr><td>2 PLC</td><td>±</td><td>-</td></tr> <tr><td>3 PLC</td><td>±</td><td>-</td></tr> <tr><td>4 PLC</td><td>±</td><td>-</td></tr> <tr><td>ANGLES</td><td>±</td><td>-</td></tr> <tr><td>FINISH</td><td>-</td><td>-</td></tr> </table>		0 PLC	±	-	1 PLC	±	-	2 PLC	±	-	3 PLC	±	-	4 PLC	±	-	ANGLES	±	-	FINISH	-	-	PRODUCT SPEC -	APPLICATION SPEC -	SIZE A2	CAGE CODE 00779	DRAWING NO C=2396234	RESTRICTED TO -
0 PLC	±	-																										
1 PLC	±	-																										
2 PLC	±	-																										
3 PLC	±	-																										
4 PLC	±	-																										
ANGLES	±	-																										
FINISH	-	-																										
MATERIAL -		WEIGHT -	CUSTOMER DRAWING		SCALE 8:1	SHEET 11 OF 12	REV 1																					

REVISIONS					
P	LTR	DESCRIPTION	DATE	DWN	APVD
-	-	SEE SHEET 1	-	-	-

CODE IDENTIFIER ON ACTUATOR

COMPLIMENT CODE—

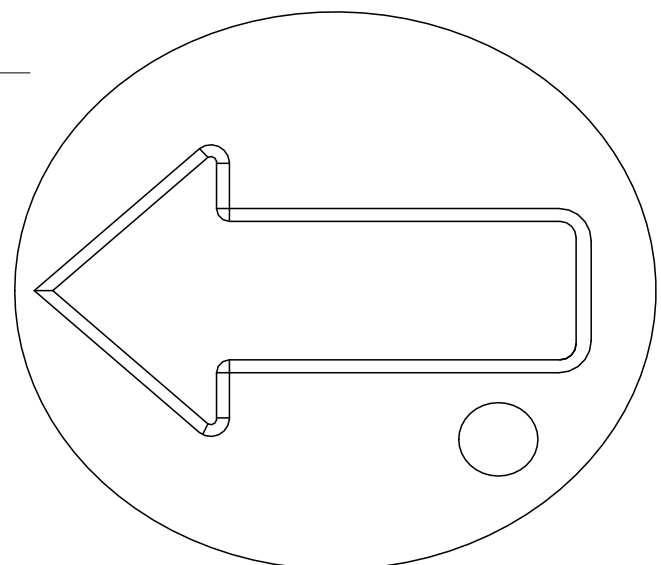

10 POSITION

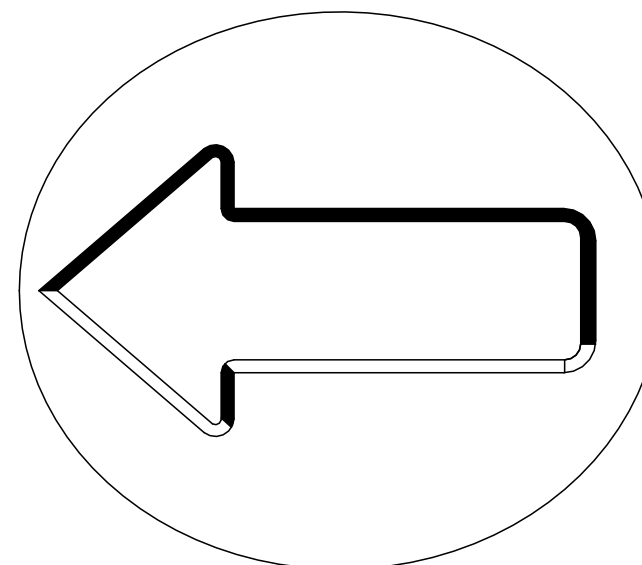

16 POSITION (NO IDENTIFIER)

GRAY CODE—

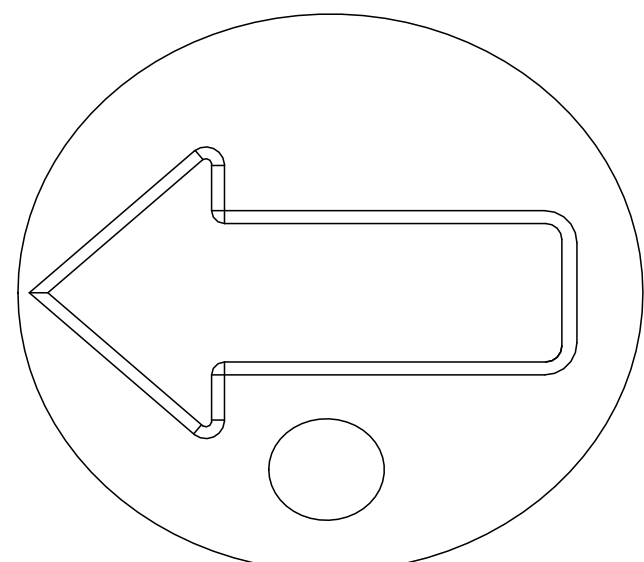

10 POSITION

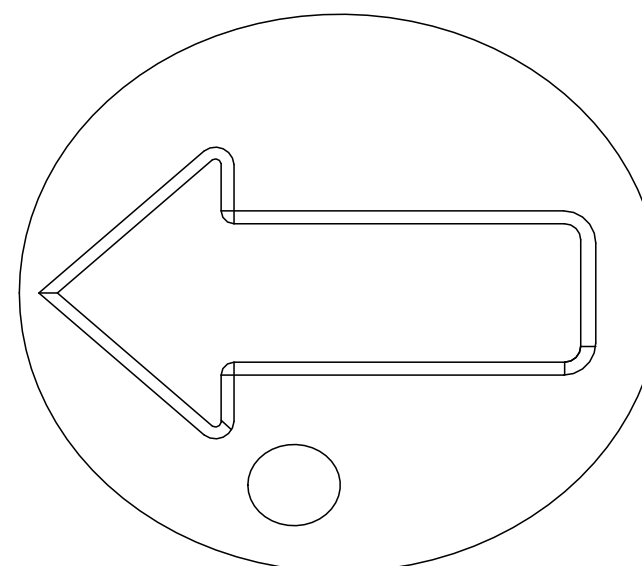

16 POSITION

REAL CODE—

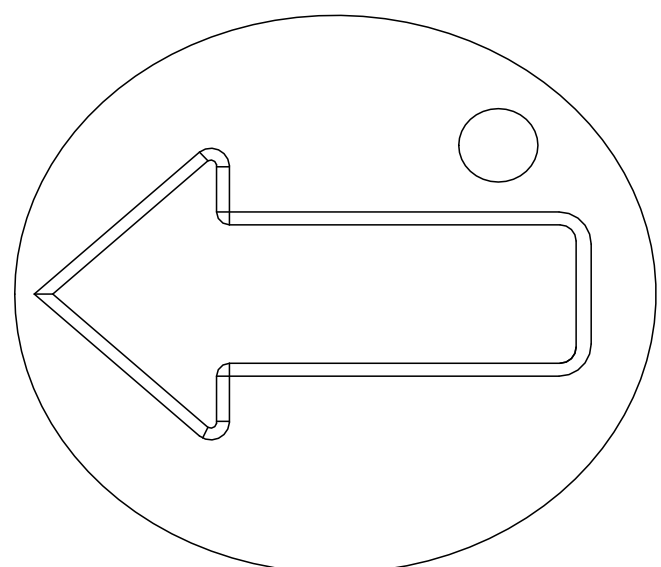

10 POSITION

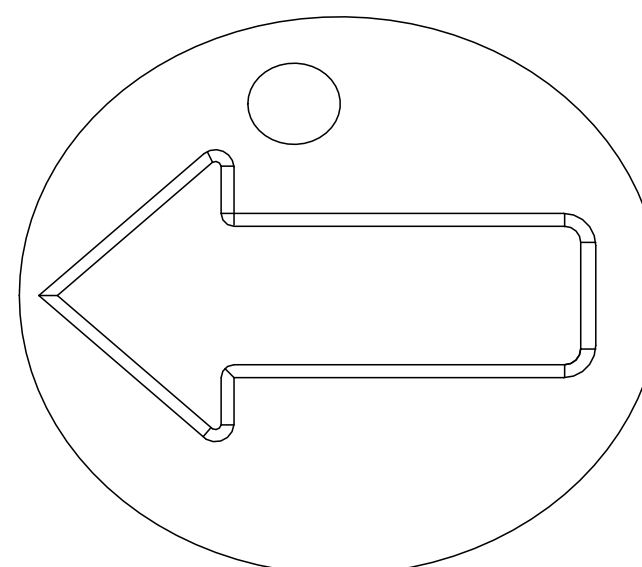

16 POSITION

PRELIMINARY

THIS DRAWING IS A CONTROLLED DOCUMENT.		DWN 19JUL2022 SATHISH KUMAR G	TE TE Connectivity																						
DIMENSIONS: mm		CHK 19JUL2022 ALEXANDER, SHARPE																							
TOLERANCES UNLESS OTHERWISE SPECIFIED:		APVD 19JUL2022 ALEXANDER, SHARPE	NAME MRSS, MINIATURE ROTARY SWITCH SERIES, VERTICAL, 2.54 BLACK, PRINT MARKING																						
<table border="1"> <tr><td>0 PLC</td><td>±</td><td>=</td></tr> <tr><td>1 PLC</td><td>±</td><td>=</td></tr> <tr><td>2 PLC</td><td>±</td><td>=</td></tr> <tr><td>3 PLC</td><td>±</td><td>=</td></tr> <tr><td>4 PLC</td><td>±</td><td>=</td></tr> <tr><td>ANGLES</td><td>±</td><td>=</td></tr> <tr><td>FINISH</td><td>-</td><td>-</td></tr> </table>		0 PLC	±	=	1 PLC	±	=	2 PLC	±	=	3 PLC	±	=	4 PLC	±	=	ANGLES	±	=	FINISH	-	-	PRODUCT SPEC -	SIZE A2	CAGE CODE 00779
0 PLC	±	=																							
1 PLC	±	=																							
2 PLC	±	=																							
3 PLC	±	=																							
4 PLC	±	=																							
ANGLES	±	=																							
FINISH	-	-																							
MATERIAL -		APPLICATION SPEC -	DRAWING NO C=2396234	RESTRICTED TO -																					
CUSTOMER DRAWING			SCALE 8:1	SHEET 12 OF 12																					
			REV 1																						