

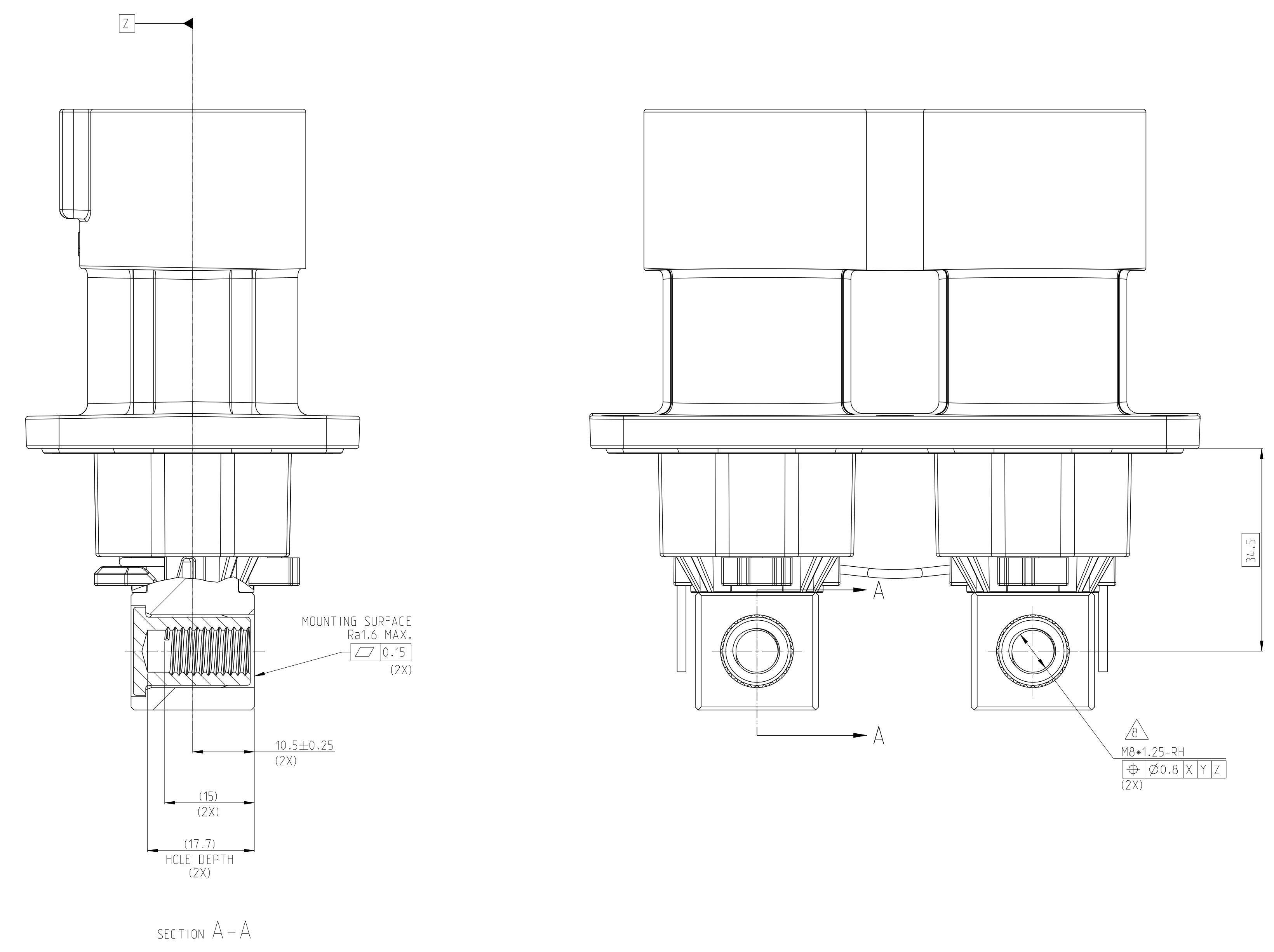

REVISIONS			
REV	DATE	BY	APPD
-	SEE SHEET 1	-	-

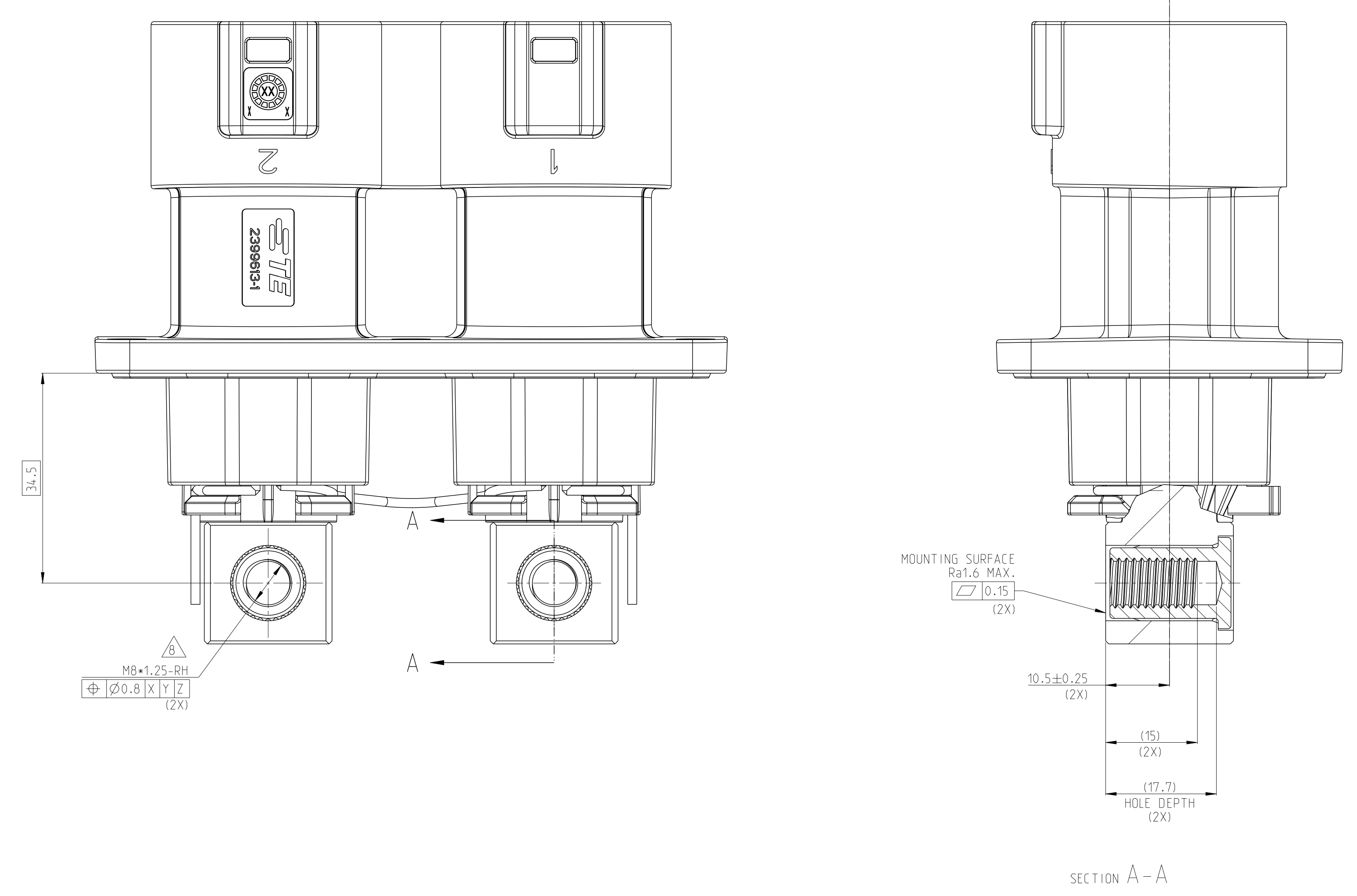

1.MISSING DIMENSIONS ACC.TO 2-2399607-1



1.MISSING DIMENSIONS ACC.TO 2-2399607-1

TE-ASSY-NO	TE REV.	CODE	DESCRIPTION	DESCRIPTION	CODE	MATERIAL	SURFACE COLOR /TREATMENT	WEIGHT (g)	QTY	ITEM
2399607-6	E	L/M	2POS.PIN DIA 14.0 HDR ASSY.180DEG	CODE HOUSING	M	PA10T-GF	AQUA RED	(485)	1	9
				CODE HOUSING	L	PA10T-GF	AQUA BROWN		1	8
				FOLLOW 2399607-1	-	-	-		-	1-7
2399607-5	E	J/K	2POS.PIN DIA 14.0 HDR ASSY.180DEG	CODE HOUSING	K	PA10T-GF	AQUA GREEN	(485)	1	9
				CODE HOUSING	J	PA10T-GF	DRANGE		1	8
				FOLLOW 2399607-1	-	-	-		-	1-7
2399607-4	E	G/H	2POS.PIN DIA 14.0 HDR ASSY.180DEG	CODE HOUSING	H	PA10T-GF	YELLOW	(485)	1	9
				CODE HOUSING	G	PA10T-GF	RED		1	8
				FOLLOW 2399607-1	-	-	-		-	1-7
2399607-3	E	E/F	2POS.PIN DIA 14.0 HDR ASSY.180DEG	CODE HOUSING	F	PA10T-GF	BROWN	(485)	1	9
				CODE HOUSING	E	PA10T-GF	GREEN		1	8
				FOLLOW 2399607-1	-	-	-		-	1-7
2399607-2	E	C/D	2POS.PIN DIA 14.0 HDR ASSY.180DEG	CODE HOUSING	D	PA10T-GF	PURPLE	(485)	1	9
				CODE HOUSING	C	PA10T-GF	BLUE		1	8
				FOLLOW 2399607-1	-	-	-		-	1-7
2399607-1	E	A/B	2POS.PIN DIA 14.0 HDR ASSY.180DEG	CODE HOUSING	B	PA10T-GF	NATURE	(485)	1	9
				CODE HOUSING	A	PA10T-GF	BLACK		1	8
				HVIL WIRELEONI MOCAR 180 E 0.5SQMM.WHITE ACCORDING TO LV112) WITH TERMINAL2	-	-	-		1	7
				HVIL WIRELEONI MOCAR 180 E 0.5SQMM.WHITE ACCORDING TO LV112) WITH TERMINAL1	-	-	-		2	6
				FACE SEAL	-	SILICONE	RED		1	5
				BUSBAR.FRONT SIDE	-	COPPER	Ag PLATED		2	4
				HEADER TPA	-	PA66-GF	RED		2	3
				FINGER PROTECTION CAP	-	PA66-GF	BLACK		2	2
				HEADER HOUSING 180DEG.2POS	-	AL-ALLOY	PASSIVATION		1	1
				TE-ASSY-NO	TE REV.	CODE	DESCRIPTION		DESCRIPTION	CODE

TE-ASSY-NO	TE REV.	CODE	DESCRIPTION	DESCRIPTION	CODE	MATERIAL	SURFACE COLOR /TREATMENT	WEIGHT (g)	QTY	ITEM
1-2399607-6	E	L/M	2POS.PIN DIA 14.0 HDR ASSY.180DEG	CODE HOUSING	M	PA10T-GF	AQUA RED	(485)	1	9
				CODE HOUSING	L	PA10T-GF	AQUA BROWN		1	8
				FOLLOW 1-2399607-1	-	-	-		-	1-7
1-2399607-5	E	J/K	2POS.PIN DIA 14.0 HDR ASSY.180DEG	CODE HOUSING	K	PA10T-GF	AQUA GREEN	(485)	1	9
				CODE HOUSING	J	PA10T-GF	DRANGE		1	8
				FOLLOW 1-2399607-1	-	-	-		-	1-7
1-2399607-4	E	G/H	2POS.PIN DIA 14.0 HDR ASSY.180DEG	CODE HOUSING	H	PA10T-GF	YELLOW	(485)	1	9
				CODE HOUSING	G	PA10T-GF	RED		1	8
				FOLLOW 1-2399607-1	-	-	-		-	1-7
1-2399607-3	E	E/F	2POS.PIN DIA 14.0 HDR ASSY.180DEG	CODE HOUSING	F	PA10T-GF	BROWN	(485)	1	9
				CODE HOUSING	E	PA10T-GF	GREEN		1	8
				FOLLOW 1-2399607-1	-	-	-		-	1-7
1-2399607-2	E	C/D	2POS.PIN DIA 14.0 HDR ASSY.180DEG	CODE HOUSING	D	PA10T-GF	PURPLE	(485)	1	9
				CODE HOUSING	C	PA10T-GF	BLUE		1	8
				FOLLOW 1-2399607-1	-	-	-		-	1-7
1-2399607-1	E	A/B	2POS.PIN DIA 14.0 HDR ASSY.180DEG	CODE HOUSING	B	PA10T-GF	NATURE	(485)	1	9
				CODE HOUSING	A	PA10T-GF	BLACK		1	8
				HVIL WIRELEONI MOCAR 180 E 0.5SQMM.WHITE ACCORDING TO LV112) WITH TERMINAL2	-	-	-		1	7
				HVIL WIRELEONI MOCAR 180 E 0.5SQMM.WHITE ACCORDING TO LV112) WITH TERMINAL1	-	-	-		2	6
				FACE SEAL	-	SILICONE	RED		1	5
				BUSBAR.BACK SIDE	-	COPPER	Ag PLATED		2	4
				HEADER TPA	-	PA66-GF	RED		2	3
				FINGER PROTECTION CAP	-	PA66-GF	BLACK		2	2
				HEADER HOUSING 180DEG.2POS	-	AL-ALLOY	PASSIVATION		1	1
				TE-ASSY-NO	TE REV.	CODE	DESCRIPTION		DESCRIPTION	CODE

THIS DRAWING IS A CONTROLLED DOCUMENT. DATE: 29DEC2021. DRAWN BY: S.TAN. CHECKED BY: J.L.L. APPROVED BY: J.L.VIN. DIMENSIONS: DIM: 10.5. MATERIAL: HVIL WIRELEONI MOCAR 180 E 0.5SQMM.WHITE ACCORDING TO LV112) WITH TERMINAL2. PRODUCT SPEC: 108-160407. APPLICATION SPEC: 114-160222. WEIGHT: SEE TABLE. CUSTOMER DRAWING. SCALE: 2:1. SHEET: 2 OF 4. REV: F1.

STC TE Connectivity

2POS.PIN DIA 14.0 HDR ASSY.180DEG HVP-HD14.00

00779 ©2399607

REVISIONS			
REV	DATE	DESCRIPTION	APP'D
-	-	SEE SHEET 1	-

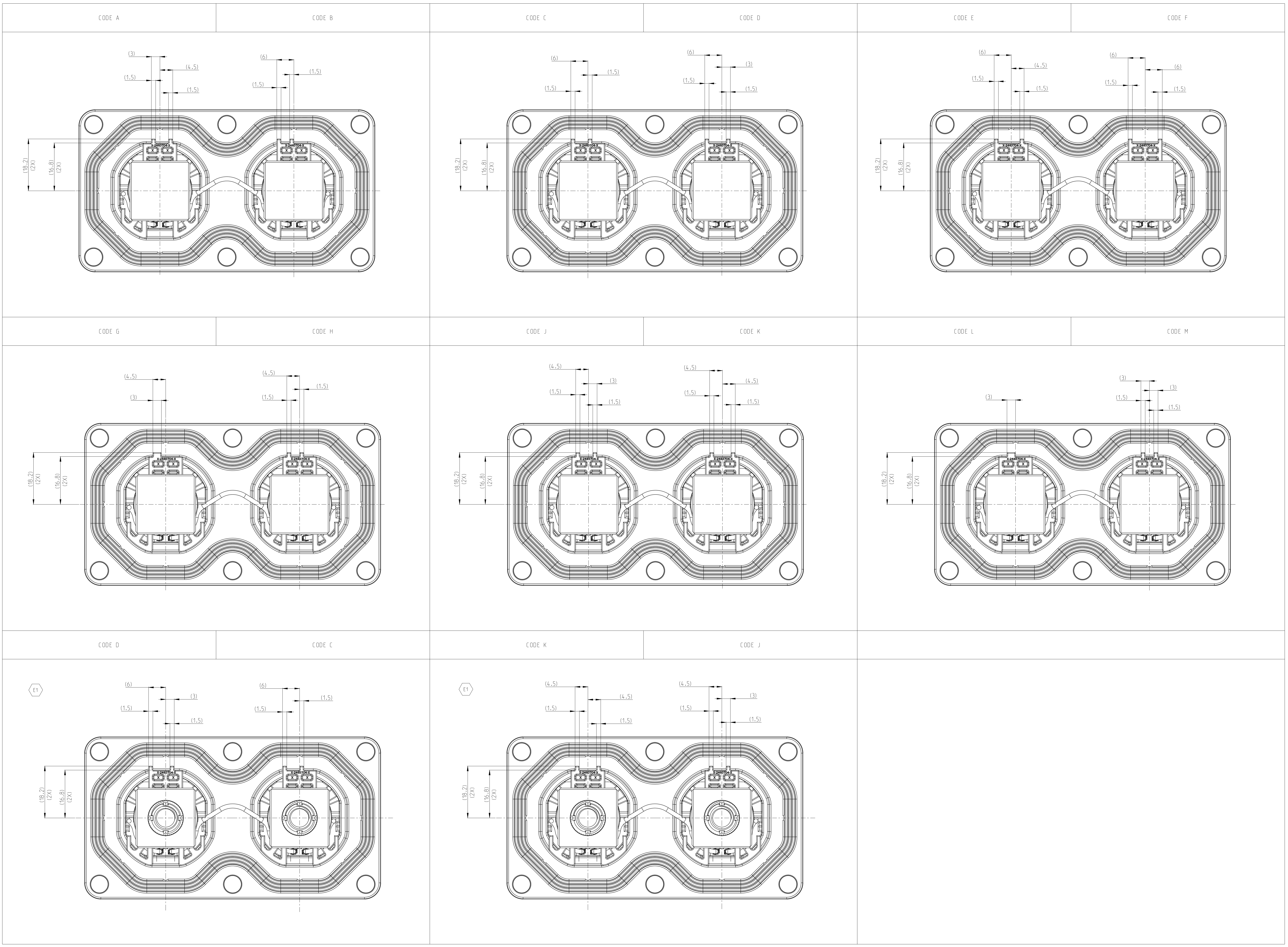

THIS DRAWING IS A CONTROLLED DOCUMENT.		DATE: 29DEC2021		TE Connectivity
DRAWN BY: S.TAN		CHK: J.L.L.		
DIMENSIONS: UNLESS OTHERWISE SPECIFIED, DIMENSIONS ARE IN MILLIMETERS.		DATE: 29DEC2021	NAME: 2POS.PIN DIA 14.0.HDR ASSY.180DEG	
PART: 14-160222		APPROVED: J.L.L.	PART NUMBER: HVP-HD14.00	
MATERIAL: SEE TABLE		PRODUCT SPEC: 14-1604.07	SITE: A0	
FINISH: SPEC 2		APPLICATION SPEC: 14-160222	CASE CODE: C=2399607	
		WEIGHT: SEE TABLE	DRAWING NO: 00779	
		CUSTOMER DRAWING	SCALE: 2:1	
			SHEET 3 OF 4	
			REV E1	

REVISIONS			
P	LV	DESCRIPTION	DATE
-	-	SEE SHEET 1	-

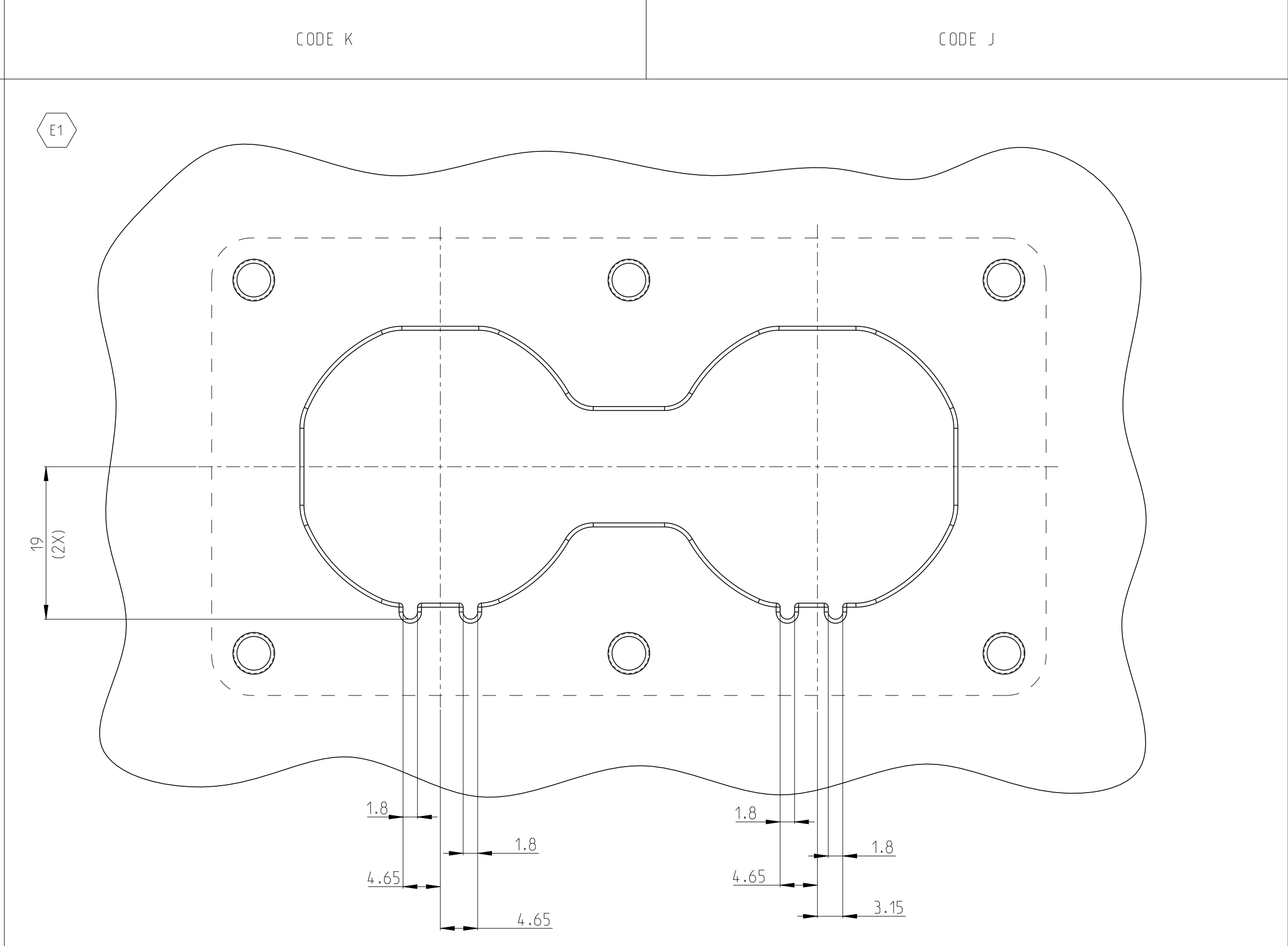
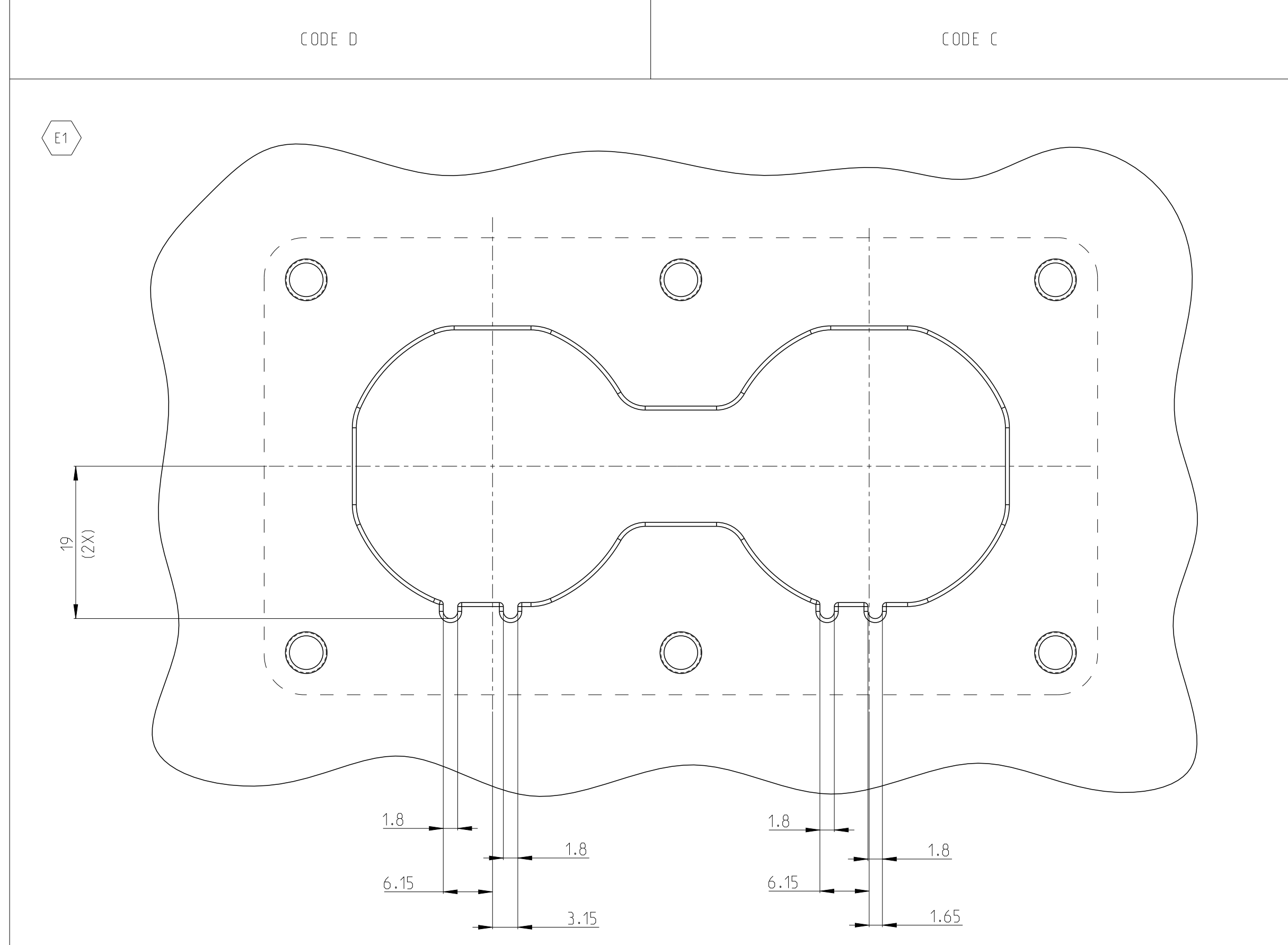
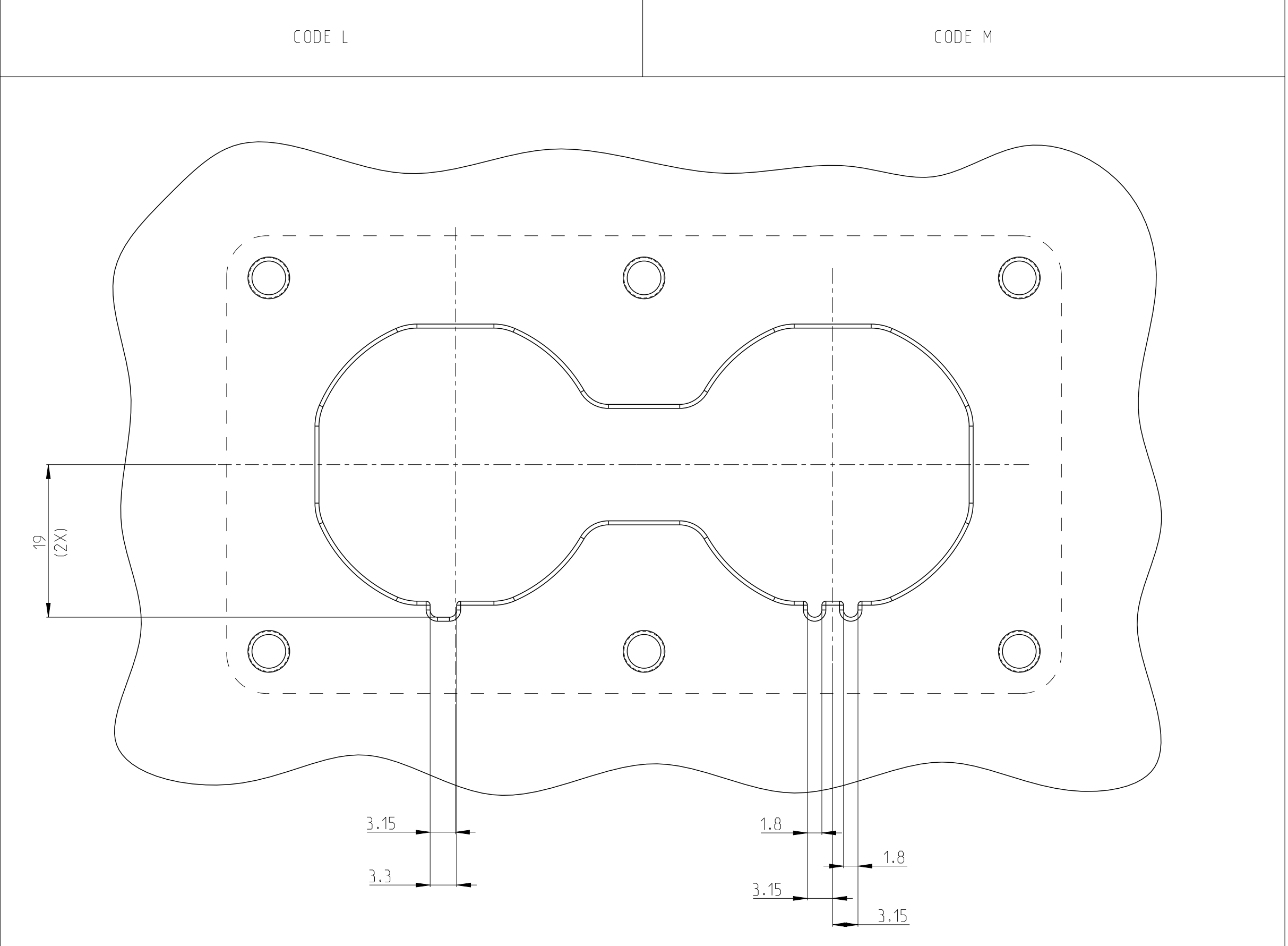
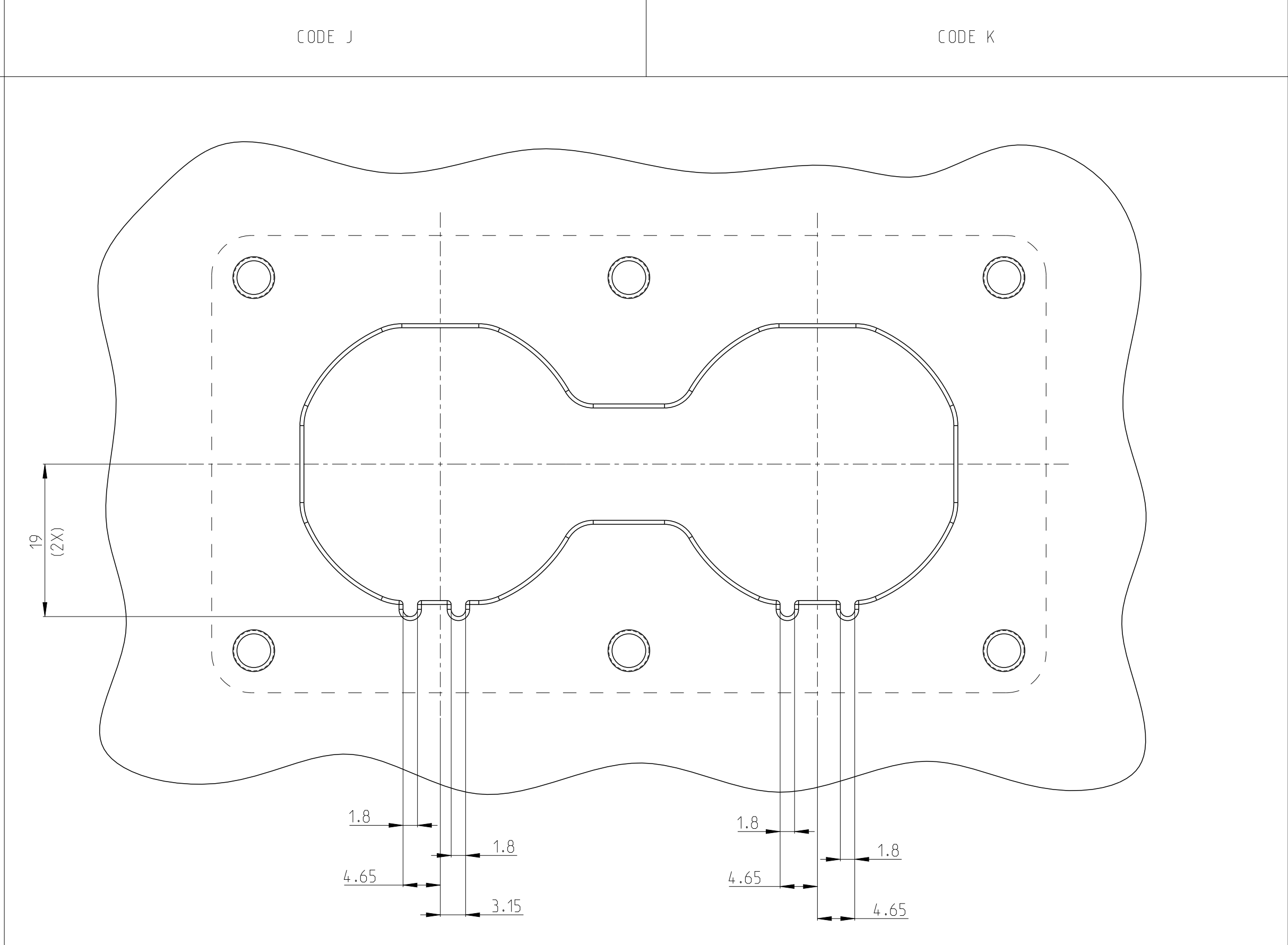
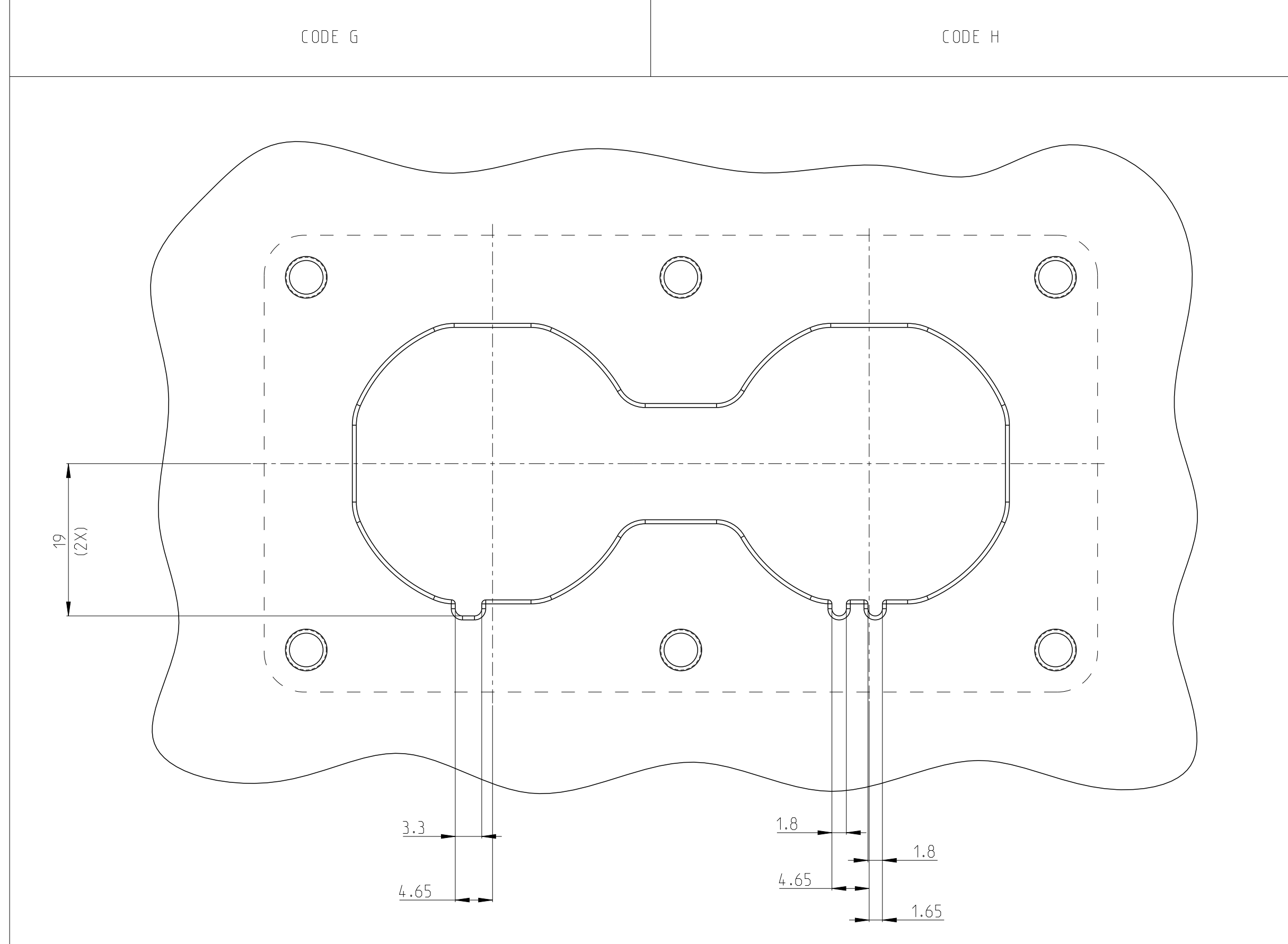
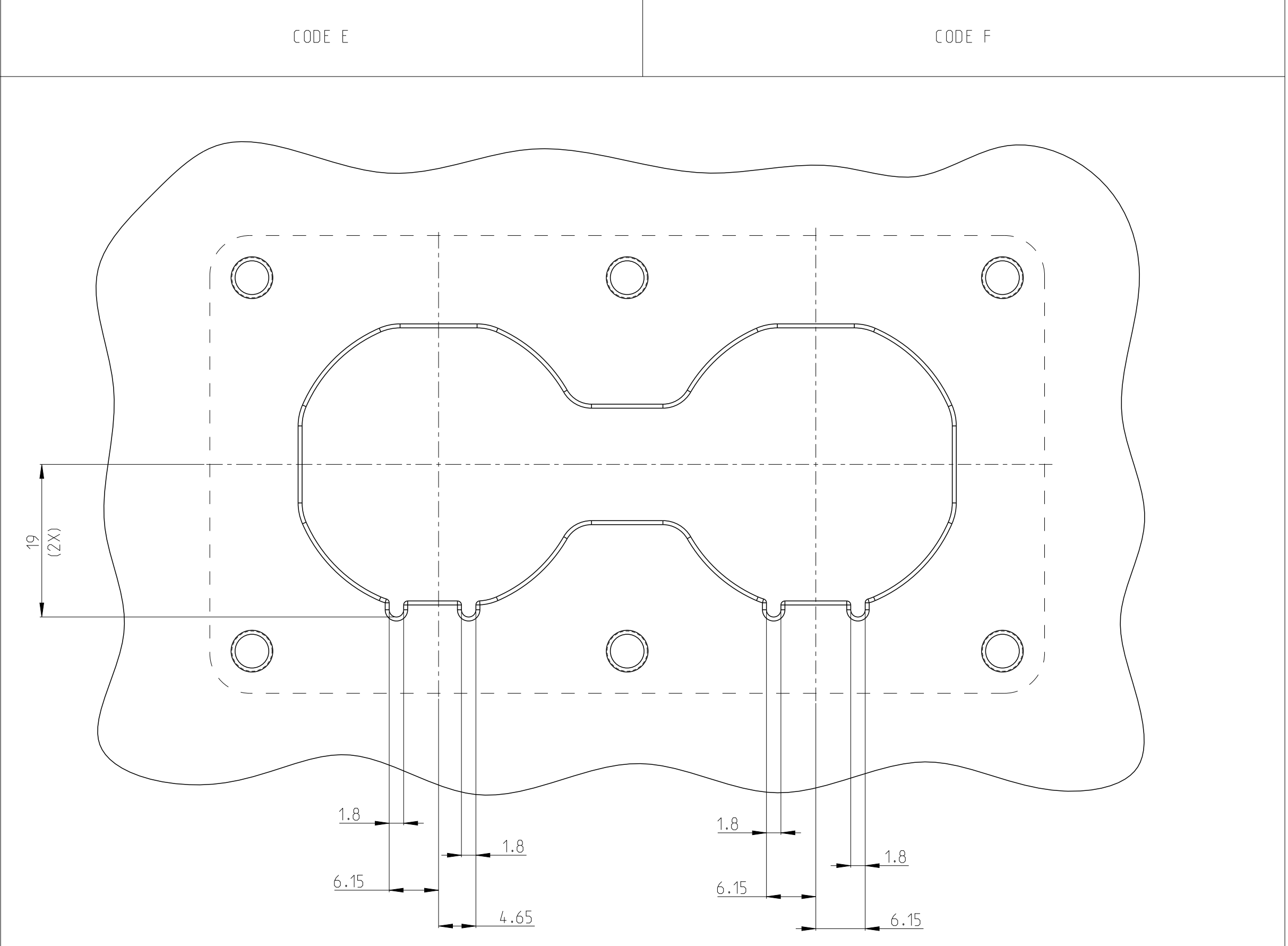
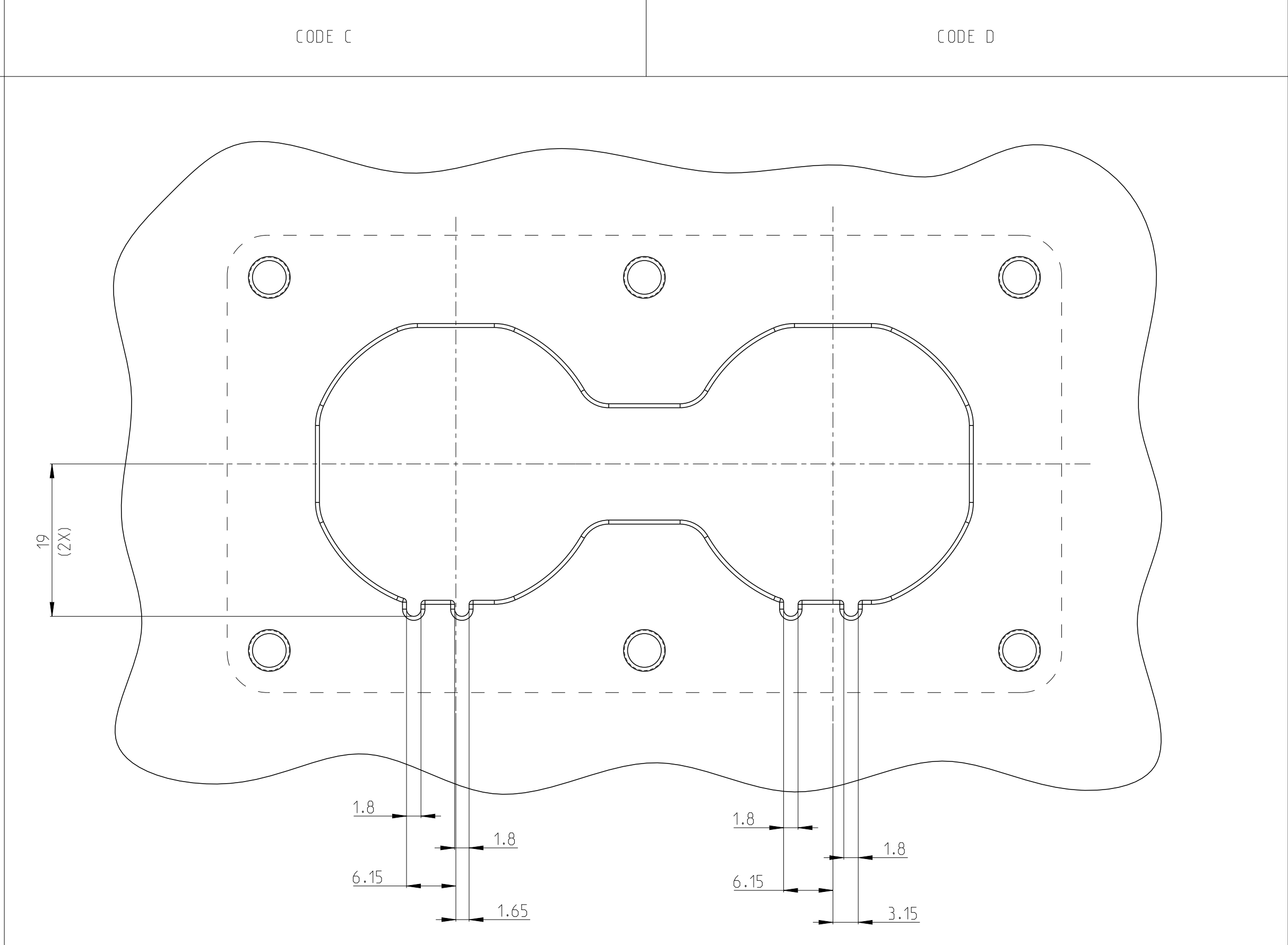
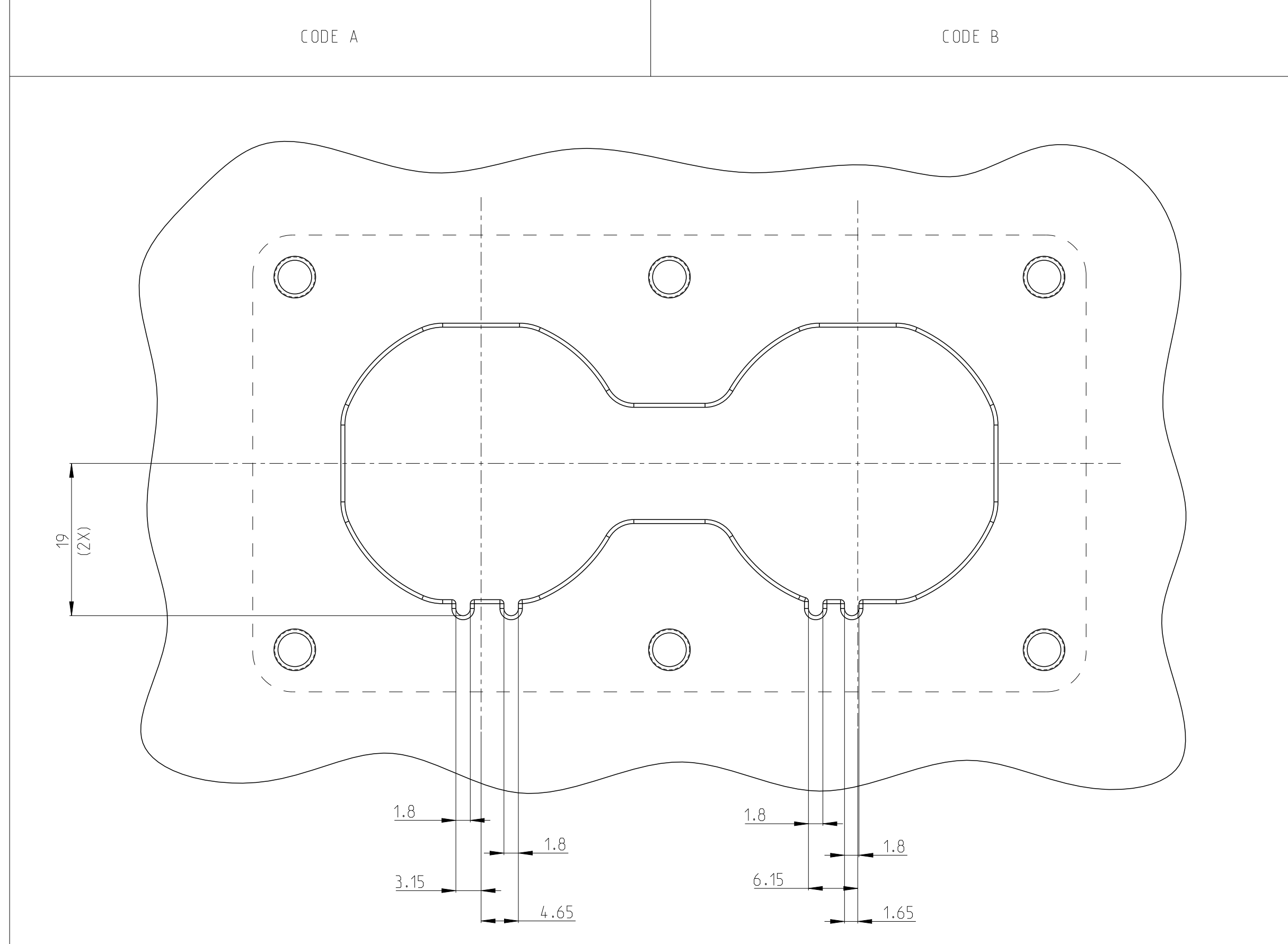

THIS DRAWING IS A CONTROLLED DOCUMENT.

DATE	29DEC2021	BY	S.TAN
CHK	29DEC2021	APPV	L.L.
REV	1	DATE	29DEC2021
DESCRIPTION	2POS.PIN DIA 14.0.HDR ASSY.180DEG HVP-HD14.00		
PRODUCT SPEC	108-1604.07		
APPLICATION SPEC	114-160222		
WEIGHT	SEE TABLE		
CUSTOMER DRAWING	A0 00779 ©=2399607		

SCALE: 2:1 SHEET 6 OF 4 REV F1