

REVISIONS					
P	LTR	DESCRIPTION	DATE	DWN	APVD
A		INITIAL RELEASE	24FEB2023	BTV	KJ

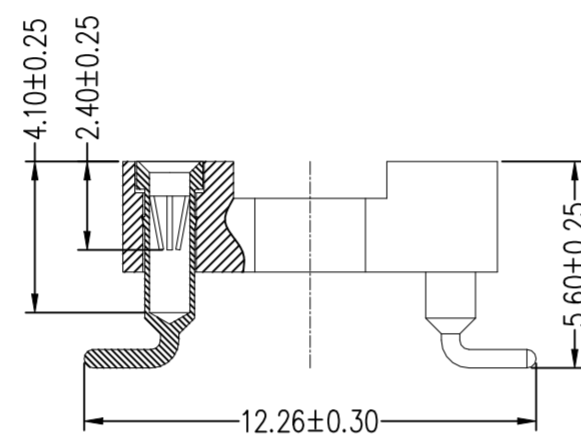

NOTES:

- MATERIAL:
 - 1, INSULATOR - THERMOPLASTIC UL-94-V-0 BLACK
 - 2, SLEEVE & CONTACT - COPPER ALLOY
- PIN SPECIFICATION: CONTACT ACCEPTS:
 - ROUND PIN ϕ 0.40 TO 0.56.
- ELECTRICAL:
 - CONTACT RESISTANCE- 10 m Ω MAX.
 - CONTACT RATING- 1Amp
 - INSULATION RESISTANCE- 10000 M Ω .
 - DIELECTRIC VOLTAGE- 1000V AC
- ENVIRONMENTAL:
 - OPERATION TEMPERATURE - -55 +125°C
 - SOLDERING PROCESS CAPABILITY - 280°C
- MECHANICAL LIFE:
 - 25 CYCLES MAX (Sn)
 - INSERTION FORCE - 200GRAMS/PIN
 - WITHDRAWAL FORCE - 60GRAMS/PIN
 - CONTACT RETENSION - 2.5KG.F MIN/PIN

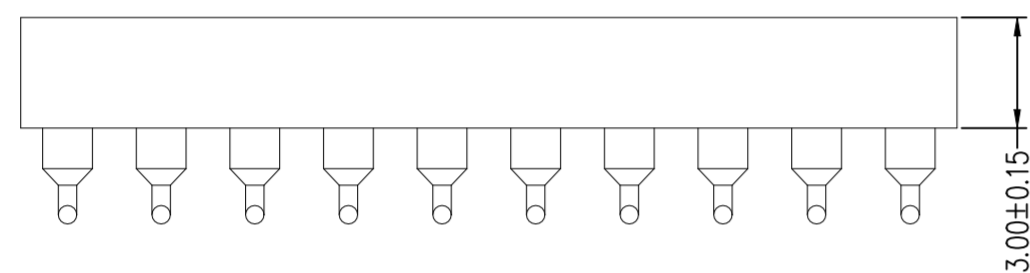
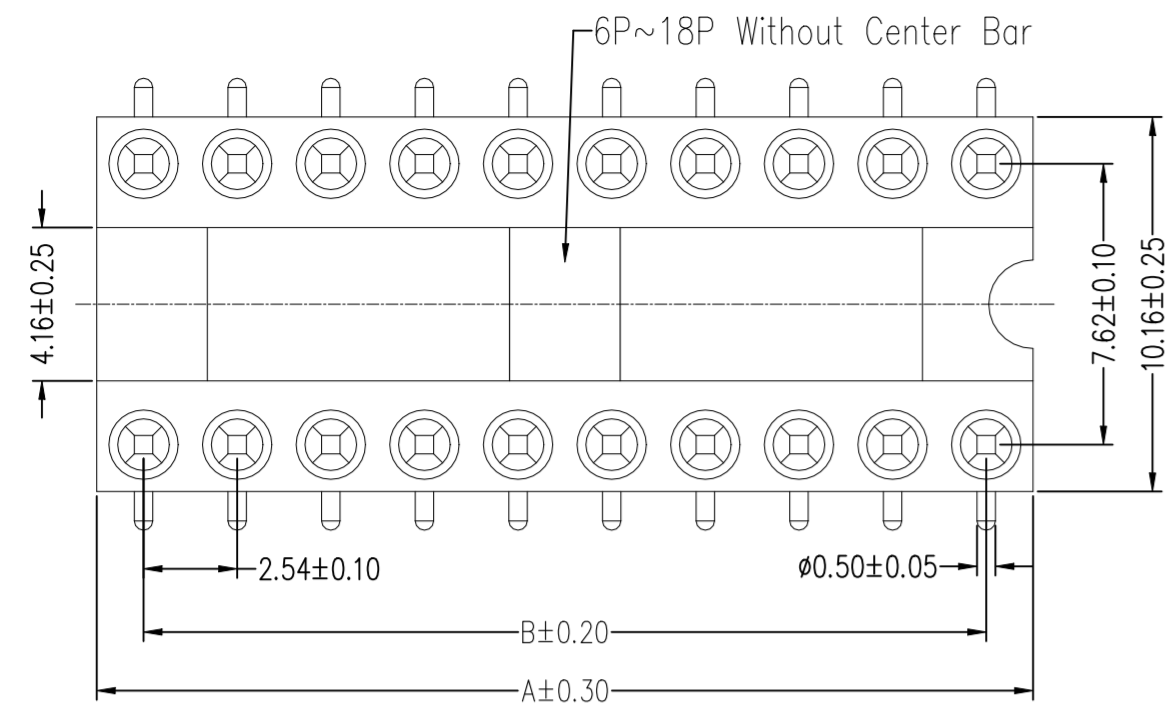
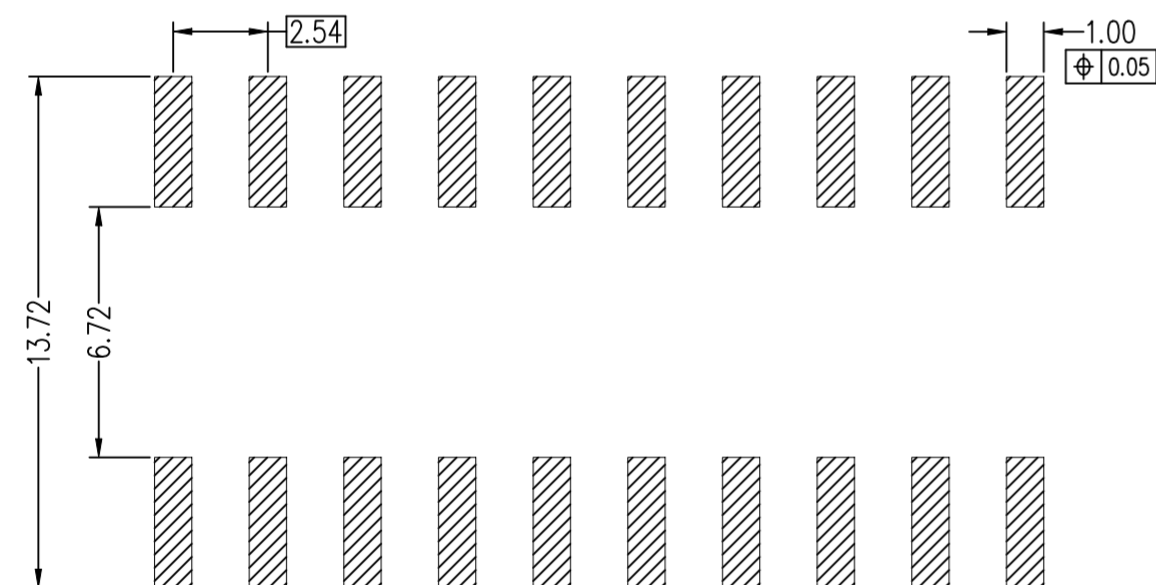

RECOMMENDED P.C.B LAYOUT (COMPONENT SIDE)(TOLERANCE:±0.05)

5 μ m Sn OVER Ni	2 μ m MIN Sn OVER 2-3 μ m Ni	20.32	17.78	16	2445893-2
5 μ m Sn OVER Ni	2 μ m MIN Sn OVER 2-3 μ m Ni	10.16	7.62	8	2445893-1
Contact Plating	Sleeve Plating	DIM A	DIM B	Number Of Positions	Part No

THIS DRAWING IS A CONTROLLED DOCUMENT.		DWN BONEY THOMAS 23DEC2022	TE Connectivity Ltd.		
DIMENSIONS: mm		CHK -	NAME DIP SOCKET SURFACE MOUNT TYPE		
TOLERANCES UNLESS OTHERWISE SPECIFIED:		APVD KIM JIN 23DEC2022	DRAWING NO -		
0 PLC ±		PRODUCT SPEC 108-160876	RESTRICTED TO -		
1 PLC ±		APPLICATION SPEC -	SIZE A2	CAGE CODE 00779	DRAWING NO C=2445893
2 PLC ±		MATERIAL -	SCALE -	SHEET 1 of 2	REV A
3 PLC ±		FINISH -	CUSTOMER DRAWING		
4 PLC ±		WEIGHT 0			
ANGLES ±					

REVISIONS					
P	LTR	DESCRIPTION	DATE	DWN	APVD
-	-	SEE SHEET 1	-	-	-

2445893-1

2445893-2

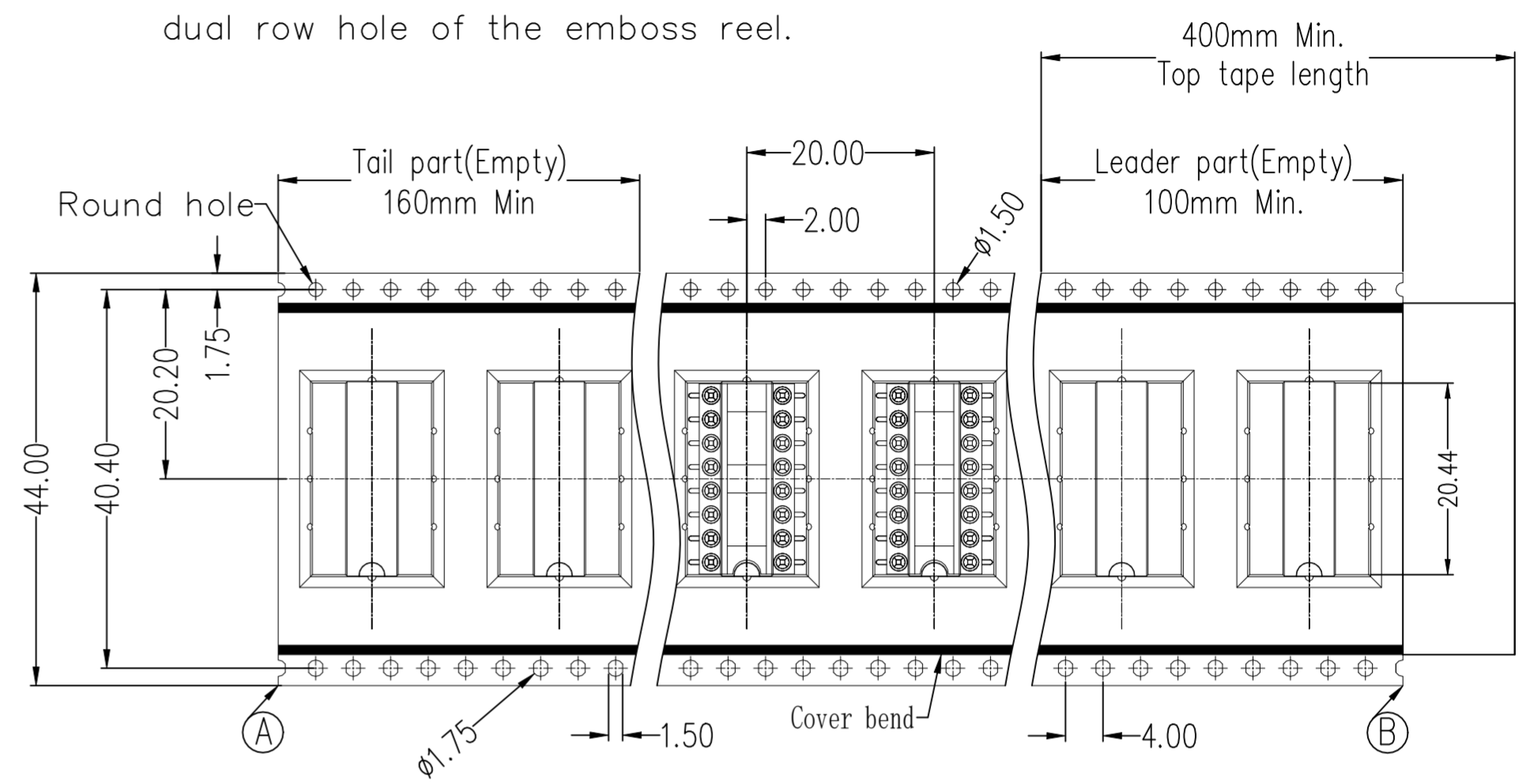
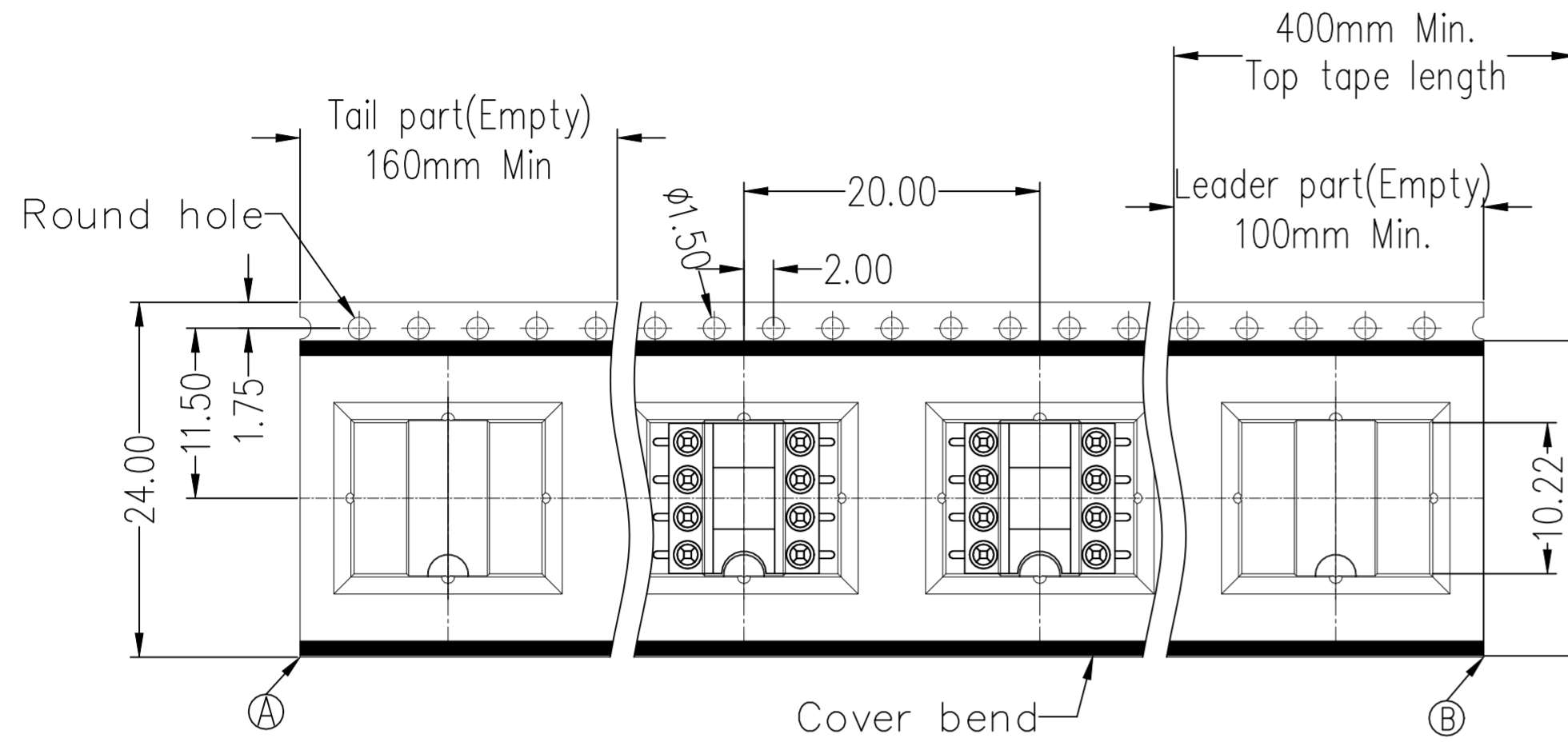

2445893-2	500	1000	3000
2445893-1	500	1500	4500
PART NUMBER	PCS/REEL	PCS/INNER BOX	PCS/OUTER BOX

THIS DRAWING IS A CONTROLLED DOCUMENT.		DWN BONEY THOMAS 23DEC2022	TE Connectivity Ltd.	
DIMENSIONS: mm		CHK -	NAME DIP SOCKET SURFACE MOUNT TYPE	
TOLERANCES UNLESS OTHERWISE SPECIFIED:		APVD KIM JIN 23DEC2022	PRODUCT SPEC 108-160876	
0 PLC ± - 1 PLC ± - 2 PLC ± - 3 PLC ± - 4 PLC ± - ANGLES ± -		MATERIAL -	FINISH -	APPLICATION SPEC -
WEIGHT 0		SIZE A2	CAGE CODE 00779	DRAWING NO C=2445893
CUSTOMER DRAWING			SCALE -	SHEET 2 of 2
				RESTRICTED TO -
				REV A