

REVISIONS					
P	LTR	DESCRIPTION	DATE	DWN	APVD
	A	GTP(ECN-23-233111)	28SEP2023	ED	WH

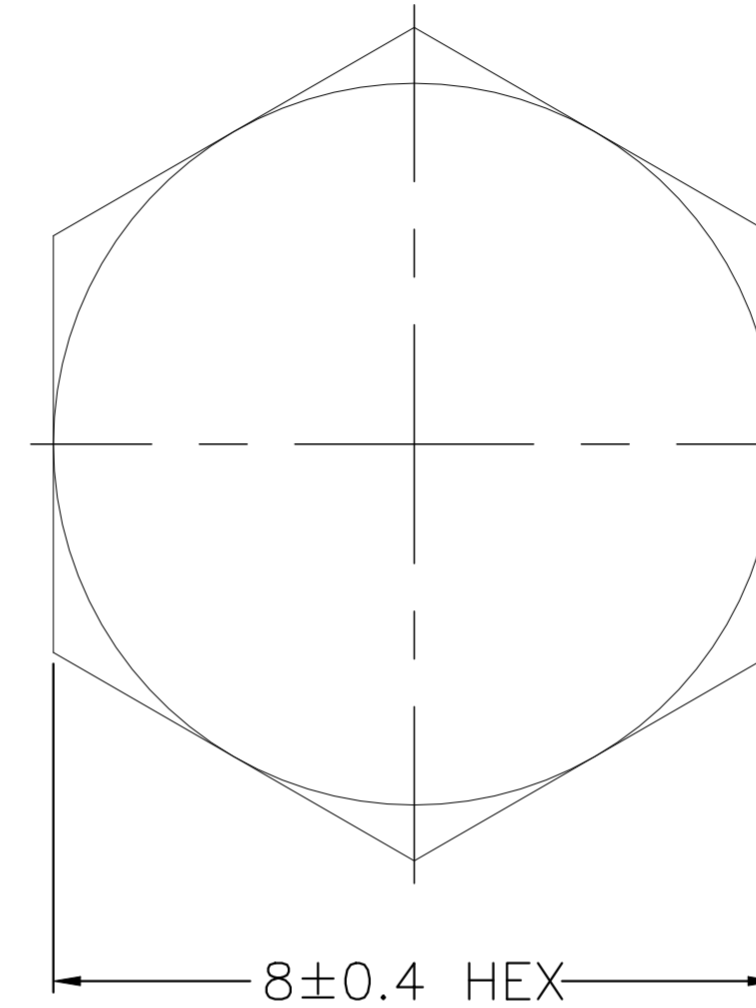
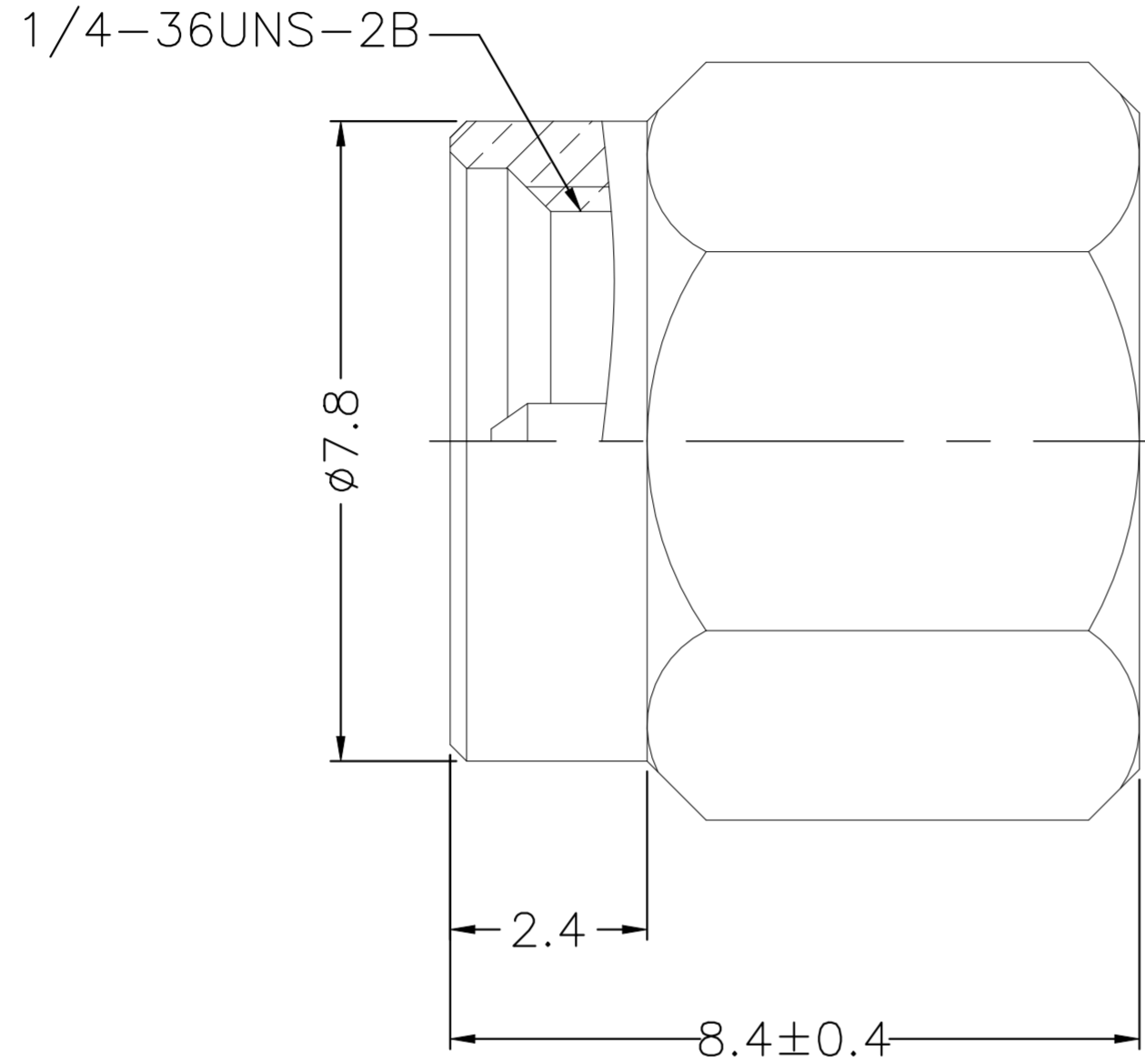

NOTES:

- 1 PACK IN ACCORDANCE WITH TE SPEC 107-3275;
- 2 ALL DIMENSIONS ARE NOMINAL FOR REFERENCE ONLY UNLESS OTHERWISE STATED;
- 3 ELECTRICAL CHARACTERISTICS :
 FREQUENCY RANGE : DC-18GHz
 NOMINAL IMPEDANCE : 50 OHMS
 POWER RATING: 2W
 VSWR : 1.3 MAX(DC-18GHz)
- 4 MECHANICAL CHARACTERISTICS :
 DURABILITY : 500 CYCLES
 TORQUE SETTING : 7-10 IN-LBS;
- 5 TEMPERATURE RANGE: -40°-+125°;
- 6 RoHS: COMPLIANT.

QUANTITY PER ASSY	DESCRIPTION	MATERIAL	DESCRIPTION	ITEM
1	RED	SILICONE RUBBER	GASKET	6
1	GOLD 1u*/ NICKEL/COPPER	BRASS	SHELL	5
1	NATURAL	REO603D	CHIP RESISTOR	4
1	GOLD 10u*/ NICKEL/COPPER	BRASS	CENTER CONTACT	3
1	NATURAL	PTFE	INSULATOR	2
1	GOLD 1u*/ NICKEL/COPPER	BRASS	BODY	1
2467938-1	PLATING	MATERIAL	DESCRIPTION	ITEM

THIS DRAWING IS A CONTROLLED DOCUMENT.		DWN ED 28SEP2023			
DIMENSIONS: mm		CHK ED 28SEP2023			
TOLERANCES UNLESS OTHERWISE SPECIFIED:		APVD WH 28SEP2023	NAME SMA MALE LOAD,CHIP RESISTOR, STRAIGHT,18GHZ		
0 PLC ± 0.3		PRODUCT SPEC	-		
1 PLC ± 0.2		APPLICATION SPEC	-		
2 PLC ± 0.1		WEIGHT	-		
3 PLC ± -		SCALE	A2 00779 C=2467938		
4 PLC ± -		CUSTOMER DRAWING	RESTRICTED TO	-	
ANGLES ± 5°		FINISH	SCALE	SHEET	REV
MATERIAL SEE TABLE		FINISH	8:1	1 OF 1	A