

P	LTR	DESCRIPTION	DATE	DWN	APVD
	A1	REVISED PER ECN-24-273961	04JUL2024	TR	GA

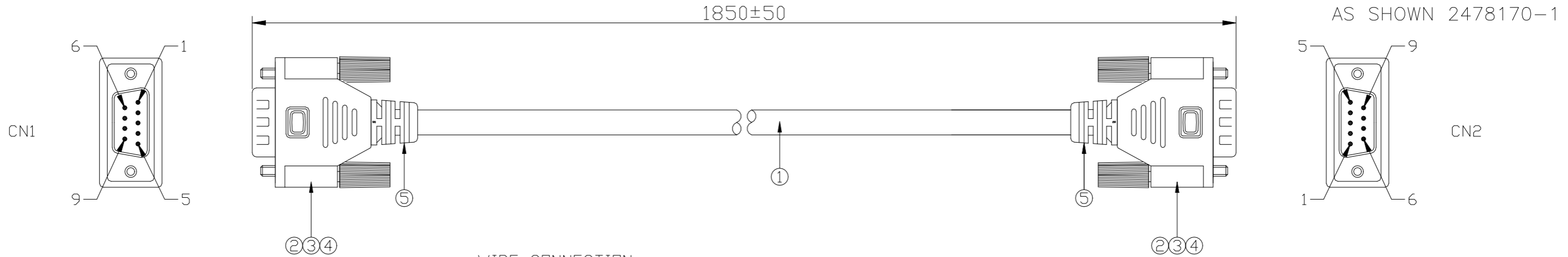

WIRE CONNECTION

CN1	WIRE COLOR	CN2
1	RED	1
2	GREEN	2
3	GRAY	3
4	BLACK	4
5	ORANGR	5
6	BLUE	6
7	YELLOW	7
8	BROWN	8
9	PURPLE	9
SHELL	DRAIN	SHELL

- NOTES:
 1.ALL PRODUCTS 100% TEST OPEN,SHORT,MISS WIRE&INTERMITTENT TEST;
 2.INSULATION RESISTANCE:300V DC/0.01S/10MΩ
 3.DIELECTRIC STRENGTH:300V AC/0.01S/1mA
 4.RESISTANCE TEST: 2Ω MAX.

S.No.	TE P/N	POSITION	GENDER	LENGTH	WIRE GAUGE	DESCRIPTION
1	2478170-1	9 TO 9	MALE TO MALE	6 FEET	28 AWG	9 POS, D SUB CABLE, 28 AWG, 6 FT, M-T-M
2	2478170-2	9 TO 9	MALE TO MALE	10 FEET	28 AWG	9 POS, D SUB CABLE, 28 AWG, 10 FT, M-T-M
3	2478170-3	9 TO 9	FEMALE TO FEMALE	6 FEET	28 AWG	9 POS, D SUB CABLE, 28 AWG, 6 FT, F-T-F
4	2478170-4	9 TO 9	FEMALE TO FEMALE	10 FEET	28 AWG	9 POS, D SUB CABLE, 28 AWG, 10 FT, F-T-F
5	2478170-5	9 TO 9	MALE TO FEMALE	5 FEET	26 AWG	9 POS, D SUB CABLE, 26 AWG, 5 FT, M-T-F
6	2478170-6	9 TO 9	MALE TO FEMALE	10 FEET	26 AWG	9 POS, D SUB CABLE, 26 AWG, 10 FT, M-T-F
7	2478170-7	9 TO 9	MALE TO FEMALE	6 FEET	28 AWG	9 POS, D SUB CABLE, 28 AWG, 6 FT, M-T-F
8	2478170-8	9 TO 9	MALE TO FEMALE	10 FEET	28 AWG	9 POS, D SUB CABLE, 28 AWG, 10 FT, M-T-F
9	2478170-9	15 TO 15	MALE TO MALE	2.5 FEET	26 AWG	15 POS, D SUB CABLE, 26 AWG, 2.5 FT, M-T-M
10	1-2478170-1	15 TO 15	MALE TO FEMALE	2.5 FEET	26 AWG	15 POS, D SUB CABLE, 26 AWG, 2.5 FT, M-T-F
11	1-2478170-2	15 TO 15	MALE TO FEMALE	5 FEET	26 AWG	15POS, D SUB CABLE, 26AWG, 5 FT, M-T-F
12	1-2478170-3	15 TO 15	MALE TO MALE	5 FEET	26 AWG	15POS, D SUB CABLE, 26AWG, 5 FT, M-T-M

ITEM	NAME	DESCRIPTION	Q'TY	UNIT
5	PVC	PVC BLACK(BH-201) 45P UL94V-0	A/R	KG
4	PE	PE NATURAL	A/R	KG
3	SCREW	#4-40 UNC NI PLATED PVC MOLDED BLACK (BH-201)	4	SET
2	CONNECTOR	DB 9P MALE PIN G/F BLACK INSULATION SHELL Sn PLATED	2	SET
1	CABLE	UL 2464 28AWG*9C+AL+D+PVC JACKET DD=5.0mm COLOR:BLACK (BH-201) VW-1	A/R	mm

THIS DRAWING IS A CONTROLLED DOCUMENT.		DWN GIRIDHAR, A 03MAY2024	TE Connectivity Ltd.	
DIMENSIONS: mm		CHK WENKE HE 05MAY2024		
TOLERANCES UNLESS OTHERWISE SPECIFIED:		APVD WENKE HE 05MAY2024	NAME DB 9P M TO M BLACK 6 FEET CABLE ASS'y	
0 PLC ± - 1 PLC ± - 2 PLC ± - 3 PLC ± - 4 PLC ± - ANGLES ± -		PRODUCT SPEC	-	
MATERIAL		APPLICATION SPEC	-	
FINISH		WEIGHT 0	SIZE A3	CAGE CODE 00779
		DRAWING NO C-2478170		RESTRICTED TO -
CUSTOMER DRAWING			SCALE 1:1	SHEET 1 OF 26
			REV A1	

REVISIONS					
P	LTR	DESCRIPTION	DATE	DWN	APVD
-	-	SEE SHEET 1	-	-	-

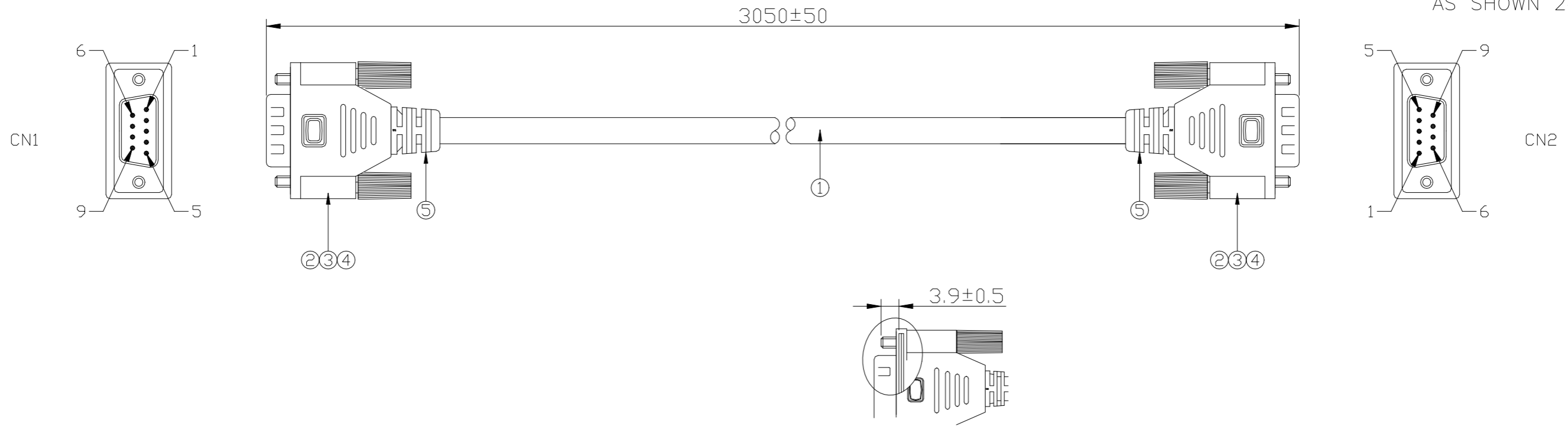

AS SHOWN 2478170-2

NOTES:
 1.ALL PRODUCTS 100% TEST OPEN,SHORT,MISS WIRE&INTERMITTENT TEST;
 2.INSULATION RESISTANCE:300V DC/0.01S/10MΩ
 3.DIELECTRIC STRENGTH:300V AC/0.01S/1mA
 4.RESISTANCE TEST: 2 Ω MAX.

WIRE CONNECTION

CN1	WIRE COLOR	CN2
1	RED	1
2	GREEN	2
3	GRAY	3
4	BLACK	4
5	ORANGR	5
6	BLUE	6
7	YELLOW	7
8	BROWN	8
9	PURPLE	9
SHELL	DRAIN	SHELL

ITEM	NAME	DESCRIPTION	Q'TY	UNIT
5	PVC	PVC BLACK(BH-201) 45P UL94V-0	A/R	KG
4	PE	PE NATURAL	A/R	KG
3	SCREW	#4-40 UNC NI PLATED PVC MOLDED BLACK (BH-201)	4	SET
2	CONNECTOR	DB 9P MALE PIN G/F BLACK INSULATION SHELL AU PLATED	2	SET
1	CABLE	UL 2464 28AWG*9C+AL+D+PVC JACKET OD=5.0mm COLOR:BLACK (BH-201) VW-1	A/R	mm

THIS DRAWING IS A CONTROLLED DOCUMENT.		DWN GIRIDHAR, A 03MAY2024	TE Connectivity Ltd.		
DIMENSIONS: mm		CHK WENKE HE 05MAY2024			
TOLERANCES UNLESS OTHERWISE SPECIFIED:		APVD WENKE HE 05MAY2024	PRODUCT SPEC		
0 PLC ± - 1 PLC ± - 2 PLC ± - 3 PLC ± - 4 PLC ± - ANGLES ± -		APPLICATION SPEC	RESTRICTED TO		
MATERIAL		WEIGHT 0	SIZE A3	CAGE CODE 00779	DRAWING NO C-2478170
FINISH		CUSTOMER DRAWING			SCALE 1:1
		SHEET 2 OF 26			REV A1

P	LTR	DESCRIPTION	DATE	DWN	APVD
-	-	SEE SHEET 1	-	-	-

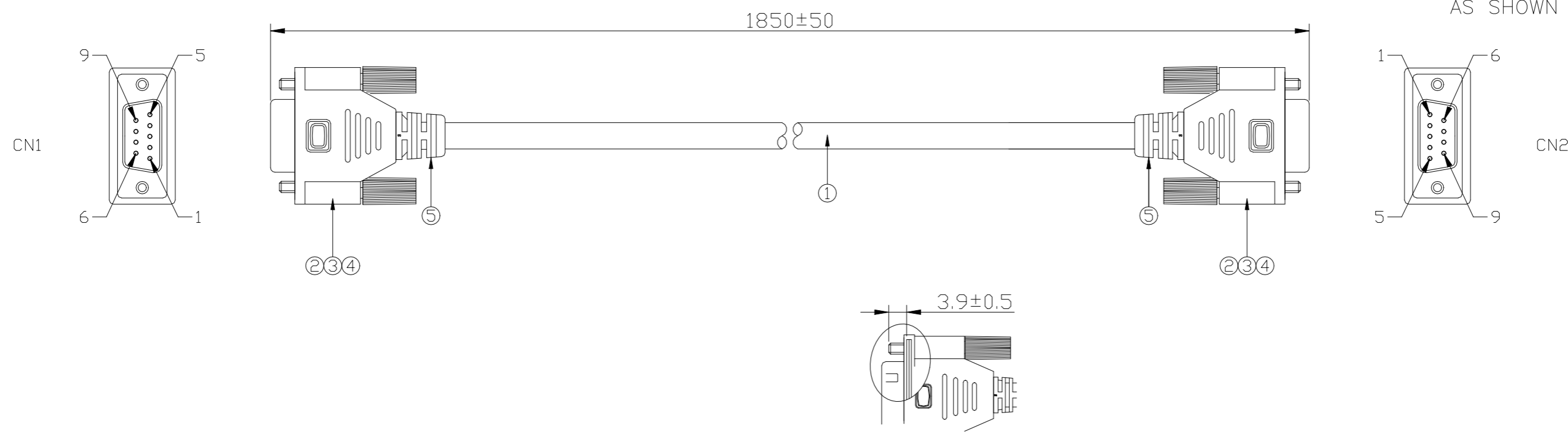

AS SHOWN 2478170-3

- NOTES:
 1.ALL PRODUCTS 100% TEST OPEN,SHORT,MISS WIRE&INTERMITTENT TEST;
 2.INSULATION RESISTANCE:300V DC/0.01S/10MΩ
 3.DIELECTRIC STRENGTH:300V AC/0.01S/1mA
 4.RESISTANCE TEST: 2 Ω MAX.

WIRE CONNECTION

CN1	WIRE COLOR	CN2
1	RED	1
2	GREEN	2
3	GRAY	3
4	BLACK	4
5	ORANGR	5
6	BLUE	6
7	YELLOW	7
8	BROWN	8
9	PURPLE	9
SHELL	DRAIN	SHELL

ITEM	NAME	DESCRIPTION	Q'TY	UNIT
5	PVC	PVC BLACK(BH-201) 45P UL94V-0	A/R	KG
4	PE	PE NATURAL	A/R	KG
3	SCREW	#4-40 UNC NI PLATED PVC MOLDED BLACK (BH-201)	4	SET
2	CONNECTOR	DB 9P FEMALE PIN G/F BLACK INSULATION SHELL AU PLATED	2	SET
1	CABLE	UL 2464 28AWG*9C+AL+D+PVC JACKET DD=5.0mm COLOR:BLACK (BH-201) VW-1	A/R	mm

THIS DRAWING IS A CONTROLLED DOCUMENT.		DWN GIRIDHAR, A 03MAY2024	TE Connectivity Ltd.													
DIMENSIONS: mm		CHK WENKE HE 05MAY2024														
TOLERANCES UNLESS OTHERWISE SPECIFIED:		APVD WENKE HE 05MAY2024	NAME DB 9P F TO F BLACK 6 FEET CABLE ASS'y													
<table border="1"> <tr><td>0 PLC</td><td>± -</td></tr> <tr><td>1 PLC</td><td>± -</td></tr> <tr><td>2 PLC</td><td>± -</td></tr> <tr><td>3 PLC</td><td>± -</td></tr> <tr><td>4 PLC</td><td>± -</td></tr> <tr><td>ANGLES</td><td>± -</td></tr> </table>		0 PLC	± -	1 PLC	± -	2 PLC	± -	3 PLC	± -	4 PLC	± -	ANGLES	± -	PRODUCT SPEC -	-	
0 PLC	± -															
1 PLC	± -															
2 PLC	± -															
3 PLC	± -															
4 PLC	± -															
ANGLES	± -															
MATERIAL -		FINISH -	APPLICATION SPEC -	-												
		WEIGHT 0	SIZE A3	CAGE CODE 00779	DRAWING NO C-2478170											
CUSTOMER DRAWING			RESTRICTED TO -	SCALE 1:1	SHEET 3 OF 26											
			REV A1													

P	LTR	DESCRIPTION	DATE	DWN	APVD
-	-	SEE SHEET 1	-	-	-

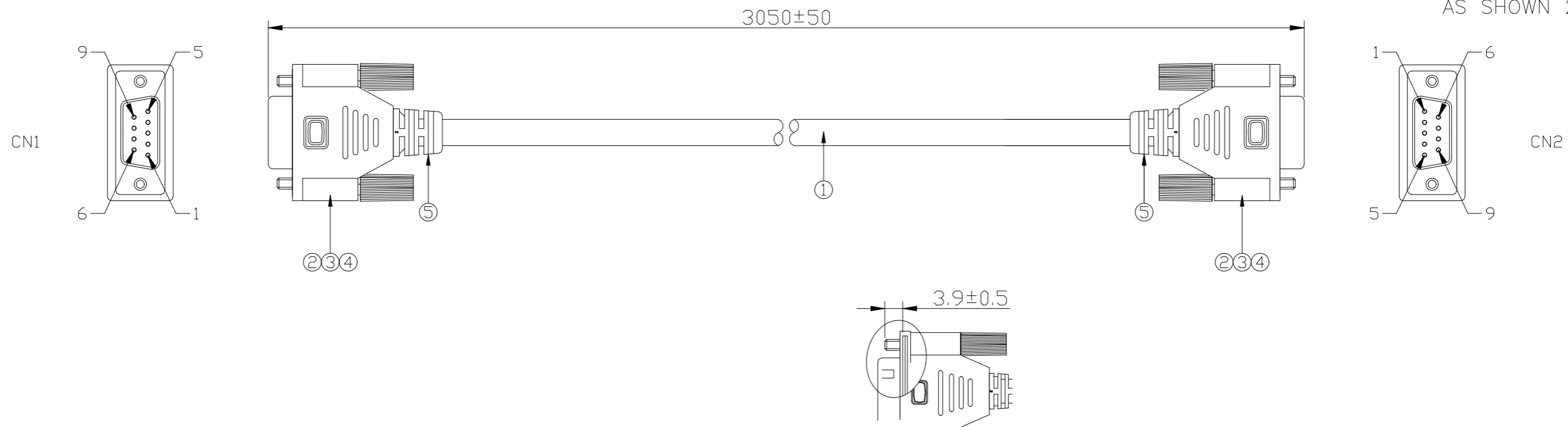

- NOTES:
- 1.ALL PRODUCTS 100% TEST OPEN,SHORT,MISS WIRE&INTERMITTENT TEST;
 - 2.INSULATION RESISTANCE:300V DC/0.01S/10MΩ
 - 3.DIELECTRIC STRENGTH:300V AC/0.01S/1mA
 - 4.RESISTANCE TEST: 2Ω MAX.

WIRE CONNECTION

CN1	WIRE COLOR	CN2
1	RED	1
2	GREEN	2
3	GRAY	3
4	BLACK	4
5	ORANGR	5
6	BLUE	6
7	YELLOW	7
8	BROWN	8
9	PURPLE	9
SHELL	DRAIN	SHELL

ITEM	NAME	DESCRIPTION	Q'TY	UNIT
5	PVC	PVC BLACK(BH-201) 45P UL94V-0	A/R	KG
4	PE	PE NATURAL	A/R	KG
3	SCREW	#4-40 UNC NI PLATED PVC MOLDED BLACK (BH-201)	4	SET
2	CONNECTOR	DB 9P FEMALE PIN G7F BLACK INSULATION SHELL AU PLATED	2	SET
1	CABLE	UL 2464 28AWG*9C+AL+D+PVC JACKET OD=5.0mm COLOR:BLACK (BH-201) VW-1	A/R	mm

THIS DRAWING IS A CONTROLLED DOCUMENT.		DWN GIRIDHAR, A 03MAY2024	TE Connectivity Ltd.	
DIMENSIONS: mm		CHK WENKE HE 05MAY2024		
TOLERANCES UNLESS OTHERWISE SPECIFIED:		APVD WENKE HE 05MAY2024	NAME DB 9P F TO F BLACK 10 FEET CABLE ASS'y	
0 PLC ± - 1 PLC ± - 2 PLC ± - 3 PLC ± - 4 PLC ± - ANGLES ± -		PRODUCT SPEC -	-	
MATERIAL -		FINISH -	APPLICATION SPEC -	RESTRICTED TO -
		WEIGHT 0	SIZE A3	CAGE CODE 00779
		DRAWING NO C-2478170		
CUSTOMER DRAWING		SCALE 1:1	SHEET 4 OF 26	REV A1

REVISIONS					
P	LTR	DESCRIPTION	DATE	DWN	APVD
-	-	SEE SHEET 1	-	-	-

AS SHOWN 2478170-5

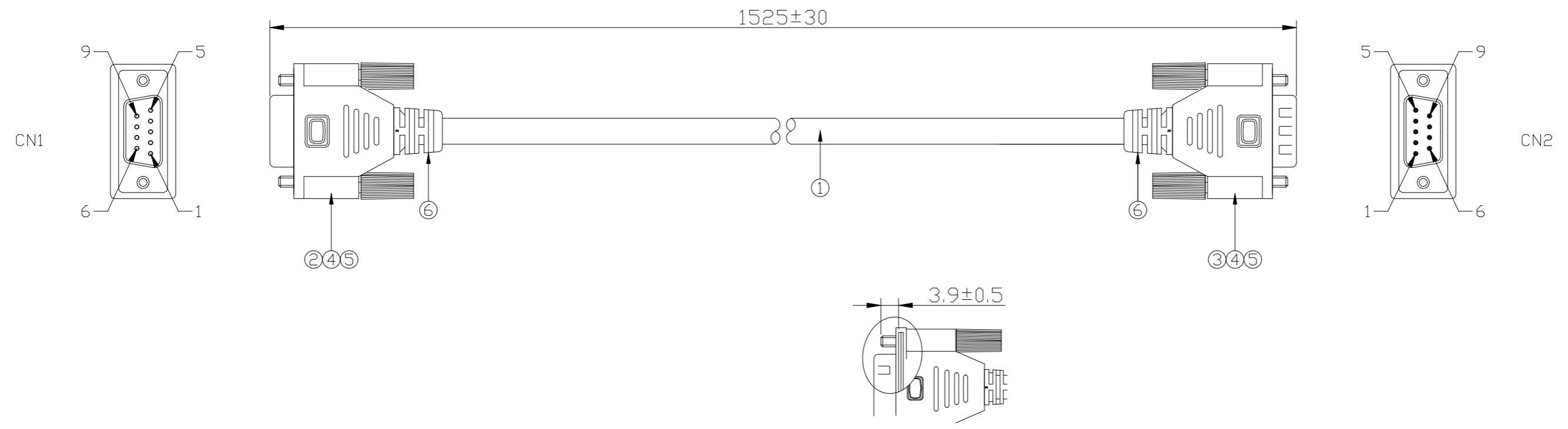

NOTES:
 1.ALL PRODUCTS 100% TEST OPEN,SHORT,MISS WIRE&INTERMITTENT TEST;
 2.INSULATION RESISTANCE:300V DC/0.01S/10MΩ
 3.DIELECTRIC STRENGTH:300V AC/0.01S/1mA
 4.RESISTANCE TEST: 2 Ω MAX.

WIRE CONNECTION

CN1	WIRE COLOR	CN2
1	RED	1
2	GREEN	2
3	GRAY	3
4	BLACK	4
5	ORANGR	5
6	BLUE	6
7	YELLOW	7
8	BROWN	8
9	PURPLE	9
SHELL	DRAIN	SHELL

ITEM	NAME	DESCRIPTION	Q'TY	UNIT
6	PVC	PVC BLACK(BH-201) 45P UL94V-0	A/R	KG
5	PE	PE NATURAL	A/R	KG
4	SCREW	#4-40 UNC NI PLATED PVC MOLDED BLACK (BH-201)	4	SET
3	CONNECTOR	DB 9P MALE PIN G/F BLACK INSULATION SHELL AU PLATED	1	SET
2	CONNECTOR	DB 9P FEMALE PIN G/F BLACK INSULATION SHELL AU PLATED	1	SET
1	CABLE	UL 2464 26AWG*9C+AL+D+PVC JACKET OD=5.8 COLOR:BLACK (BH-201) VW-1	A/R	mm

THIS DRAWING IS A CONTROLLED DOCUMENT.		DWN GIRIDHAR, A 03MAY2024	TE Connectivity Ltd.													
DIMENSIONS: mm		CHK WENKE HE 05MAY2024														
TOLERANCES UNLESS OTHERWISE SPECIFIED:		APVD WENKE HE 05MAY2024	NAME DB 9P F TO F BLACK 6 FEET CABLE ASS'y													
<table border="1"> <tr><td>0 PLC</td><td>± -</td></tr> <tr><td>1 PLC</td><td>± -</td></tr> <tr><td>2 PLC</td><td>± -</td></tr> <tr><td>3 PLC</td><td>± -</td></tr> <tr><td>4 PLC</td><td>± -</td></tr> <tr><td>ANGLES</td><td>± -</td></tr> </table>		0 PLC	± -	1 PLC	± -	2 PLC	± -	3 PLC	± -	4 PLC	± -	ANGLES	± -	PRODUCT SPEC -	-	
0 PLC	± -															
1 PLC	± -															
2 PLC	± -															
3 PLC	± -															
4 PLC	± -															
ANGLES	± -															
MATERIAL -		FINISH -	APPLICATION SPEC -	-												
		WEIGHT 0	SIZE A3	CAGE CODE 00779	DRAWING NO C-2478170											
CUSTOMER DRAWING			RESTRICTED TO -	SCALE 1:1	SHEET 5 OF 26											
			REV A1													

REVISIONS					
P	LTR	DESCRIPTION	DATE	DWN	APVD
-	-	SEE SHEET 1	-	-	-

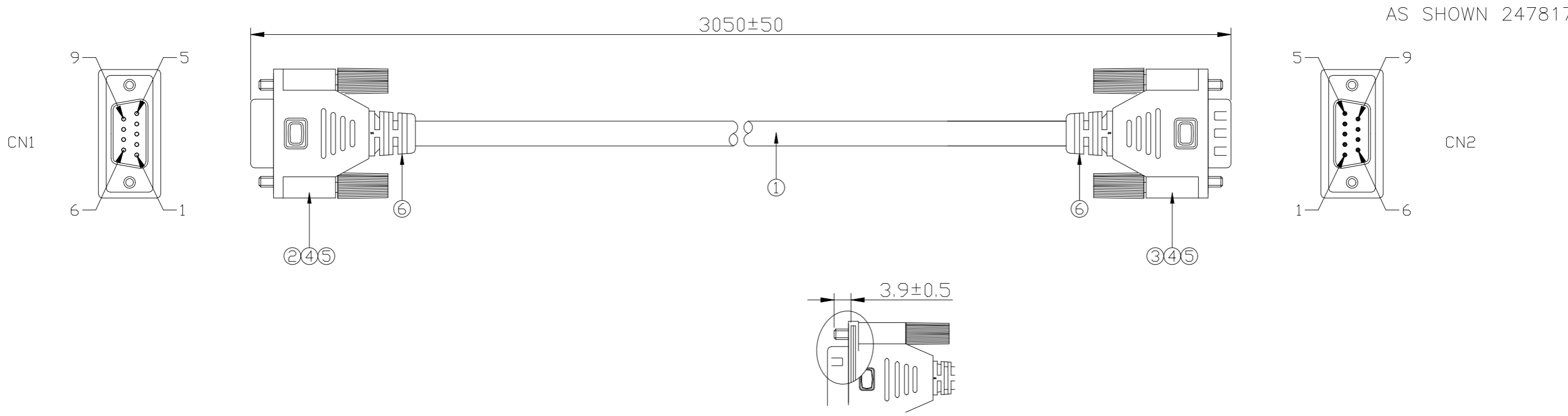

NOTES:
 1.ALL PRODUCTS 100% TEST OPEN,SHORT,MISS WIRE&INTERMITTENT TEST;
 2.INSULATION RESISTANCE:300V DC/0.01S/10MΩ
 3.DIELECTRIC STRENGTH:300V AC/0.01S/1mA
 4.RESISTANCE TEST: 2 Ω MAX.

WIRE CONNECTION

CN1	WIRE COLOR	CN2
1	RED	1
2	GREEN	2
3	GRAY	3
4	BLACK	4
5	ORANGR	5
6	BLUE	6
7	YELLOW	7
8	BROWN	8
9	PURPLE	9
SHELL	DRAIN	SHELL

ITEM	NAME	DESCRIPTION	Q'TY	UNIT
6	PVC	PVC BLACK(BH-201) 45P UL94V-0	A/R	KG
5	PE	PE NATURAL	A/R	KG
4	SCREW	#4-40 UNC NI PLATED PVC MOLDED BLACK (BH-201)	4	SET
3	CONNECTOR	DB 9P MALE PIN G/F BLACK INSULATION SHELL Sn PLATED	1	SET
2	CONNECTOR	DB 9P FEMALE PIN G/F BLACK INSULATION SHELL Sn PLATED	1	SET
1	CABLE	UL 2464 26AWG*9C+AL+D+PVC JACKET OD=5.8mm COLOR:BLACK (BH-201) VW-1	A/R	mm

THIS DRAWING IS A CONTROLLED DOCUMENT.		DWN GIRIDHAR, A 03MAY2024	TE Connectivity Ltd.	
DIMENSIONS: mm		CHK WENKE HE 05MAY2024		
		APVD WENKE HE 05MAY2024	NAME DB 9P M TO F BLACK 10 FEET CABLE ASS'y	
TOLERANCES UNLESS OTHERWISE SPECIFIED:		PRODUCT SPEC	-	
0 PLC ± - 1 PLC ± - 2 PLC ± - 3 PLC ± - 4 PLC ± - ANGLES ± -		APPLICATION SPEC	-	
MATERIAL		WEIGHT 0	SIZE A3	CAGE CODE 00779
FINISH		DRAWING NO C-2478170		RESTRICTED TO -
CUSTOMER DRAWING			SCALE 1:1	SHEET 6 OF 26
			REV A1	

REVISIONS					
P	LTR	DESCRIPTION	DATE	DWN	APVD
-	-	SEE SHEET 1	-	-	-

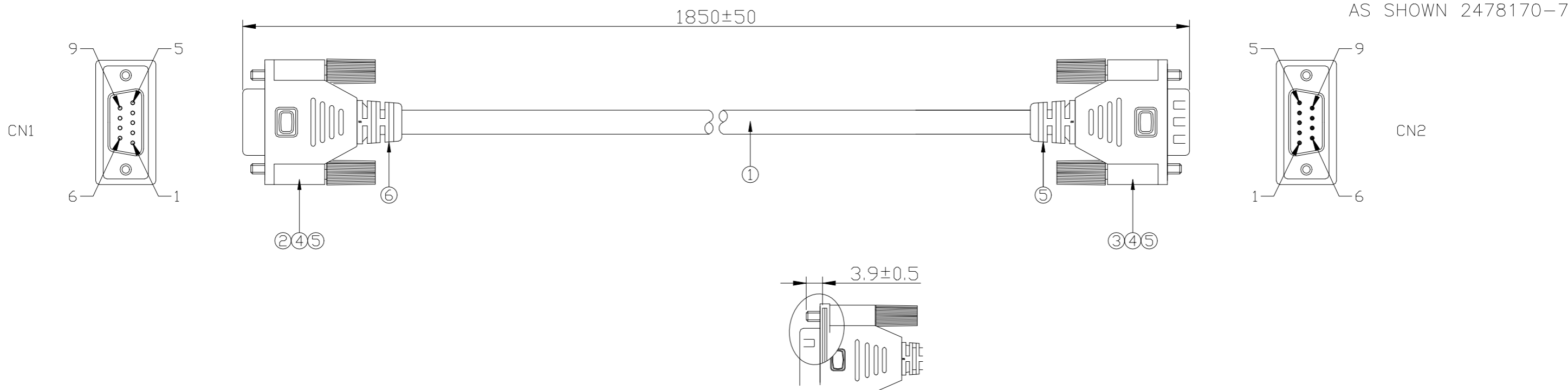

- NOTES:
 1.ALL PRODUCTS 100% TEST OPEN,SHORT,MISS WIRE&INTERMITTENT TEST;
 2.INSULATION RESISTANCE:300V DC/0.01S/10MΩ
 3.DIELECTRIC STRENGTH:300V AC/0.01S/1mA
 4.RESISTANCE TEST: 2 Ω MAX.

WIRE CONNECTION

CN1	WIRE COLOR	CN2
1	RED	1
2	GREEN	2
3	GRAY	3
4	BLACK	4
5	ORANGR	5
6	BLUE	6
7	YELLOW	7
8	BROWN	8
9	PURPLE	9
SHELL	DRAIN	SHELL

ITEM	NAME	DESCRIPTION	Q'TY	UNIT
6	PVC	PVC BLACK(BH-201) 45P UL94V-0	A/R	KG
5	PE	PE NATURAL	A/R	KG
4	SCREW	#4-40 UNC NI PLATED PVC MOLDED BLACK (BH-201)	4	SET
3	CONNECTOR	DB 9P MALE PIN G/F BLACK INSULATION SHELL AU PLATED	1	SET
2	CONNECTOR	DB 9P FEMALE PIN G/F BLACK INSULATION SHELL AU PLATED	1	SET
1	CABLE	UL 2464 26AWG*9C+AL+D+PVC JACKET DD=5.8 COLOR:BLACK (BH-201) VW-1	A/R	mm

THIS DRAWING IS A CONTROLLED DOCUMENT.		DWN GIRIDHAR, A 03MAY2024	TE Connectivity Ltd.	
DIMENSIONS: mm		CHK WENKE HE 05MAY2024		
		APVD WENKE HE 05MAY2024	NAME DB 9P M TO F BLACK 6 FEET CABLE ASS'y	
TOLERANCES UNLESS OTHERWISE SPECIFIED:		PRODUCT SPEC	-	
0 PLC ± - 1 PLC ± - 2 PLC ± - 3 PLC ± - 4 PLC ± - ANGLES ± -		APPLICATION SPEC	-	
MATERIAL		WEIGHT 0	SIZE A3	CAGE CODE 00779
FINISH		DRAWING NO C-2478170		RESTRICTED TO -
CUSTOMER DRAWING			SCALE 1:1	SHEET 7 OF 26
			REV A1	

REVISIONS					
P	LTR	DESCRIPTION	DATE	DWN	APVD
-	-	SEE SHEET 1	-	-	-

AS SHOWN 2478170-8

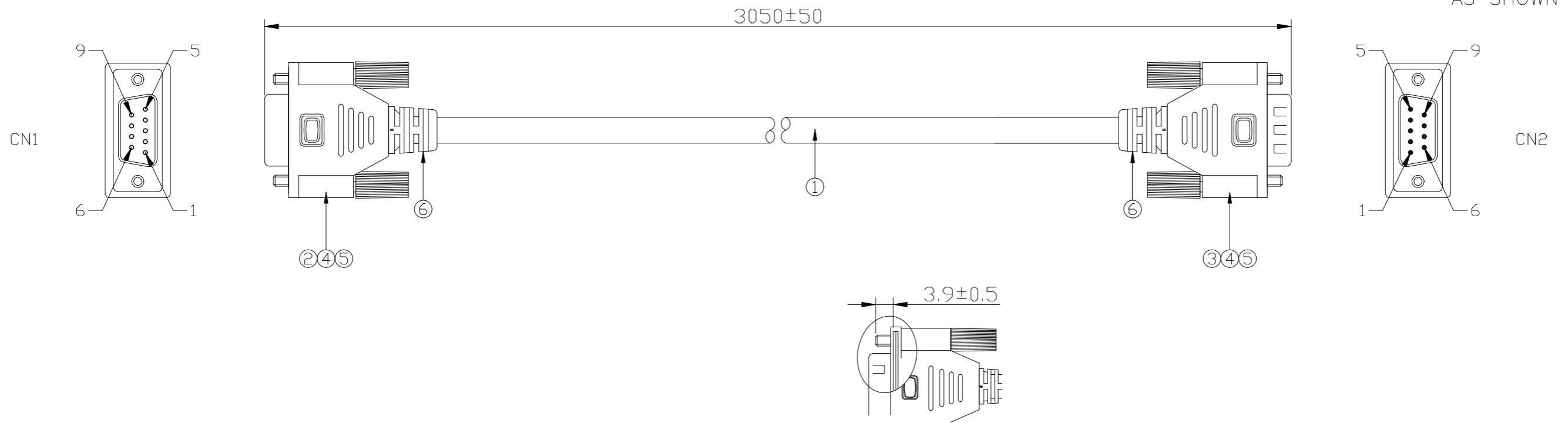

- NOTES:
 1.ALL PRODUCTS 100% TEST OPEN,SHORT,MISS WIRE&INTERMITTENT TEST;
 2.INSULATION RESISTANCE:300V DC/0.01S/10MΩ
 3.DIELECTRIC STRENGTH:300V AC/0.01S/1mA
 4.RESISTANCE TEST: 2 Ω MAX.

WIRE CONNECTION

CN1	WIRE COLOR	CN2
1	RED	1
2	GREEN	2
3	GRAY	3
4	BLACK	4
5	ORANGR	5
6	BLUE	6
7	YELLOW	7
8	BROWN	8
9	PURPLE	9
SHELL	DRAIN	SHELL

ITEM	NAME	DESCRIPTION	Q'TY	UNIT
6	PVC	PVC BLACK(BH-201) 45P UL94V-0	A/R	KG
5	PE	PE NATURAL	A/R	KG
4	SCREW	#4-40 UNC NI PLATED PVC MOLDED BLACK (BH-201)	4	SET
3	CONNECTOR	DB 9P MALE PIN G/F BLACK INSULATION SHELL Sn PLATED	1	SET
2	CONNECTOR	DB 9P FEMALE PIN G/F BLACK INSULATION SHELL Sn PLATED	1	SET
1	CABLE	UL 2464 28AWG*9C+AL+D+PVC JACKET OD=5.0mm COLOR:BLACK (BH-201) VW-1	A/R	mm

THIS DRAWING IS A CONTROLLED DOCUMENT.		DWN GIRIDHAR, A 03MAY2024	TE Connectivity Ltd.		
DIMENSIONS: mm		CHK WENKE HE 05MAY2024			
TOLERANCES UNLESS OTHERWISE SPECIFIED:		APVD WENKE HE 05MAY2024	PRODUCT SPEC		
0 PLC ± - 1 PLC ± - 2 PLC ± - 3 PLC ± - 4 PLC ± - ANGLES ± -		APPLICATION SPEC	RESTRICTED TO		
MATERIAL		WEIGHT 0	SIZE A3	CAGE CODE 00779	DRAWING NO C-2478170
FINISH		CUSTOMER DRAWING		SCALE 1:1	SHEET 8 OF 26
				REV A1	

REVISIONS					
P	LTR	DESCRIPTION	DATE	DWN	APVD
-	-	SEE SHEET 1	-	-	-

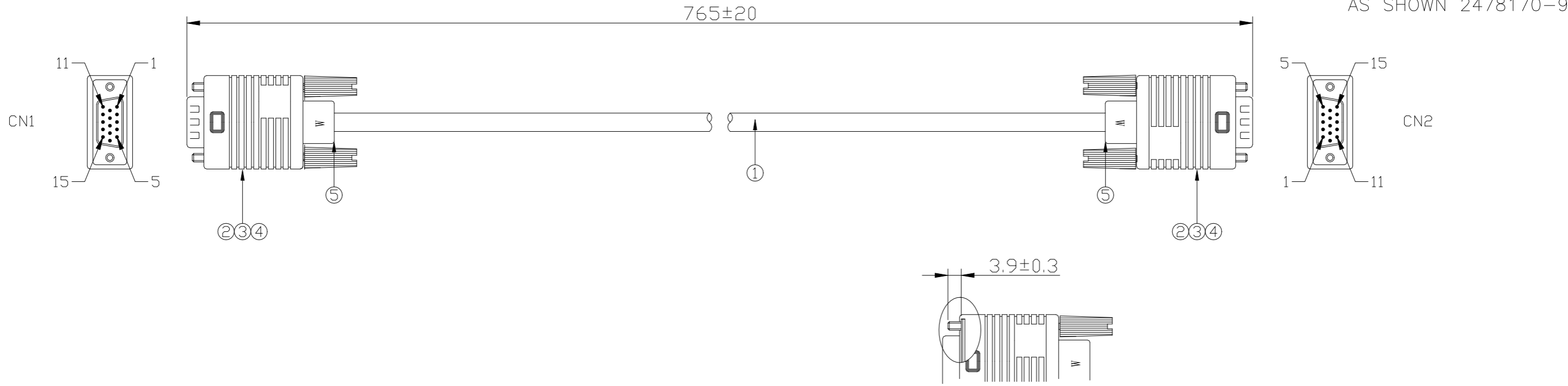

NOTES:
 1.ALL PRODUCTS 100% TEST OPEN,SHORT,MISS WIRE&INTERMITTENT TEST;
 2.INSULATION RESISTANCE:300V DC/0.01S/10MΩ
 3.DIELECTRIC STRENGTH:300V AC/0.01S/1mA
 4.RESISTANCE TEST: 2 Ω MAX.

WIRE CONNECTION

CN1	WIRE COLOR	CN2
1	RED	1
2	WHITE	2
3	DARK GREEN	3
4	BLACK	4
5	BROWN	5
6	PINK	6
7	LIGHT GREEN	7
8	GRAY	8
9	PURPLE	9
10	BLUE	10
11	RED & WHITE	11
12	ORANGE	12
13	YELLOW	13
14	BLACK & WHITE	14
15	BROWN & WHITE	15
SHELL	DRAIN	SHELL

ITEM	NAME	DESCRIPTION	Q'TY	UNIT
5	PVC	PVC BLACK(BH-201) 45P UL94V-0	A/R	KG
4	PE	PE NATURAL	A/R	KG
3	SCREW	#4-40 UNC NI PLATED MOLDED COLOR BLACK (BH-201)	4	PCS
2	CONNECTOR	DB 15P MALE PIN G/F BLACK INSULATION SHELL AU PLATED	2	SET
1	CABLE	UL20276 26AWG*15C+AL+D+PVC JACKET DD=6.2mm COLOR:BLACK (BH-201) VW-1	A/R	mm

THIS DRAWING IS A CONTROLLED DOCUMENT.		DWN GIRIDHAR, A 03MAY2024	TE Connectivity Ltd.	
DIMENSIONS: mm		CHK WENKE HE 05MAY2024		
TOLERANCES UNLESS OTHERWISE SPECIFIED:		APVD WENKE HE 05MAY2024	NAME DB 15P M TO M BLACK 2.5 FEET CABLE ASS'y	
		PRODUCT SPEC	-	
MATERIAL		APPLICATION SPEC	-	
FINISH		WEIGHT 0	SIZE A3	CAGE CODE 00779
		DRAWING NO C-2478170		RESTRICTED TO -
CUSTOMER DRAWING		SCALE 1:1	SHEET 9 of 26	REV A1

P	LTR	DESCRIPTION	DATE	DWN	APVD
-	-	SEE SHEET 1	-	-	-

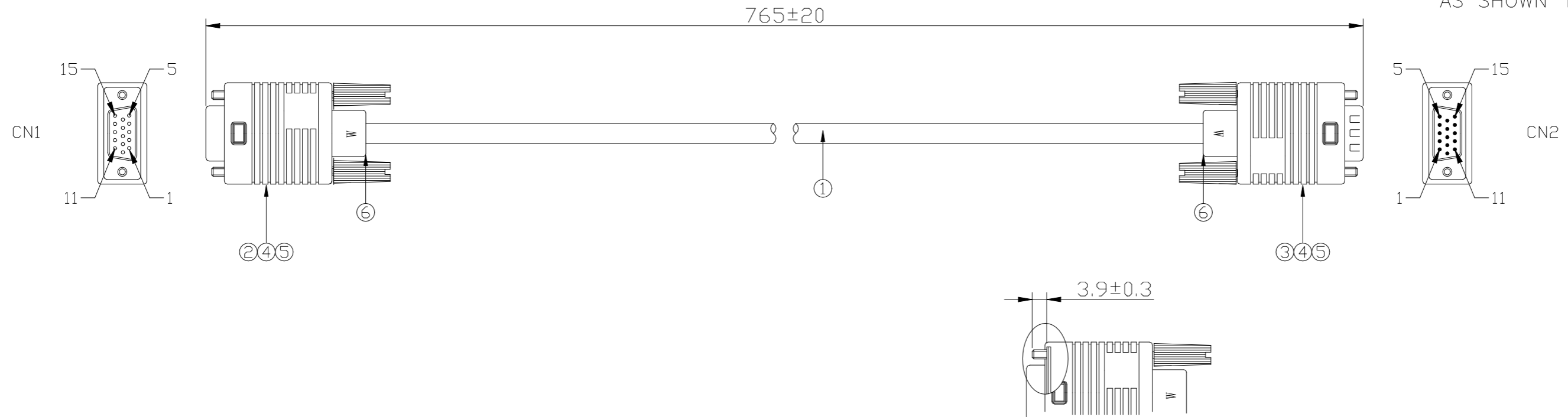

AS SHOWN 1-2478170-1

NOTES:
 1.ALL PRODUCTS 100% TEST OPEN,SHORT,MISS WIRE&INTERMITTENT TEST;
 2.INSULATION RESISTANCE:300V DC/0.01S/10MΩ
 3.DIELECTRIC STRENGTH:300V AC/0.01S/1mA
 4.RESISTANCE TEST: 2 Ω MAX.

WIRE CONNECTION

CN1	WIRE COLOR	CN2
1	RED	1
2	WHITE	2
3	DARK GREEN	3
4	BLACK	4
5	BROWN	5
6	PINK	6
7	LIGHT GREEN	7
8	GRAY	8
9	PURPLE	9
10	BLUE	10
11	RED & WHITE	11
12	ORANGE	12
13	YELLOW	13
14	BLACK & WHITE	14
15	BROWN & WHITE	15
SHELL	DRAIN	SHELL

ITEM	NAME	DESCRIPTION	Q'TY	UNIT
6	PVC	PVC BLACK(BH-201) 45P UL94V-0	A/R	KG
5	PE	PE NATURAL	A/R	KG
4	SCREW	#4-40 UNC NI PLATED MOLDED COLOR BLACK (BH-201)	4	PCS
3	CONNECTOR	DB 15P MALE PIN G/F BLACK INSULATION SHELL Sn PLATED	1	SET
2	CONNECTOR	DB 15P FEMALE PIN G/F BLACK INSULATION SHELL Sn PLATED	1	SET
1	CABLE	UL20276 26AWG*15C+AL+D+PVC JACKET OD=6.2mm COLOR:BLACK (BH-201) VW-1	A/R	mm

THIS DRAWING IS A CONTROLLED DOCUMENT.		DWN GIRIDHAR, A 03MAY2024	TE Connectivity Ltd.	
DIMENSIONS: mm		CHK WENKE HE 05MAY2024		
TOLERANCES UNLESS OTHERWISE SPECIFIED:		APVD WENKE HE 05MAY2024	NAME DB 15P M TO F BLACK 2.5 FEET CABLE ASS'y	
		PRODUCT SPEC	-	
MATERIAL		APPLICATION SPEC	-	
FINISH		WEIGHT 0	SIZE A3	RESTRICTED TO -
		FINISH -	CAGE CODE 00779	DRAWING NO C-2478170
			SCALE 1:1	SHEET 10 OF 26
			REV A1	

P	LTR	DESCRIPTION	DATE	DWN	APVD
-	-	SEE SHEET 1	-	-	-

AS SHOWN 1-2478170-2

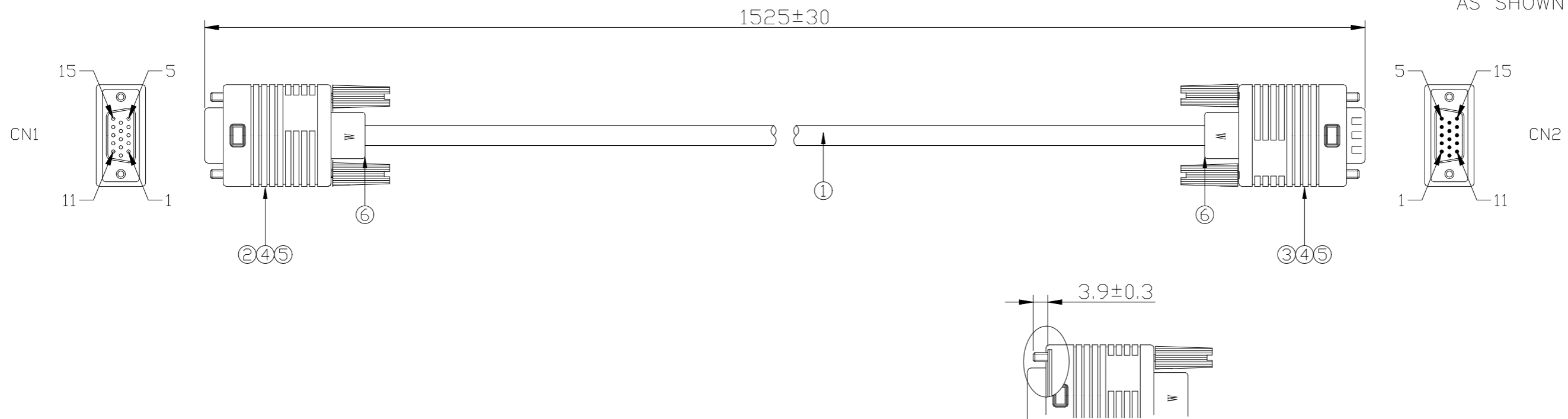

- NOTES:
 1. ALL PRODUCTS 100% TEST OPEN, SHORT, MISS WIRE & INTERMITTENT TEST;
 2. INSULATION RESISTANCE: 300V DC / 0.01S / 10MΩ
 3. DIELECTRIC STRENGTH: 300V AC / 0.01S / 1mA
 4. RESISTANCE TEST: 2 Ω MAX.

WIRE CONNECTION

CN1	WIRE COLOR	CN2
1	RED	1
2	WHITE	2
3	DARK GREEN	3
4	BLACK	4
5	BROWN	5
6	PINK	6
7	LIGHT GREEN	7
8	GRAY	8
9	PURPLE	9
10	BLUE	10
11	RED & WHITE	11
12	ORANGE	12
13	YELLOW	13
14	BLACK & WHITE	14
15	BROWN & WHITE	15
SHELL	DRAIN	SHELL

ITEM	NAME	DESCRIPTION	Q'TY	UNIT
6	PVC	PVC BLACK (BH-201) 45P UL94V-0	A/R	KG
5	PE	PE NATURAL	A/R	KG
4	SCREW	#4-40 UNC NI PLATED MOLDED COLOR BLACK (BH-201)	4	PCS
3	CONNECTOR	DB 15P MALE PIN G/F BLACK INSULATION SHELL Sn PLATED	1	SET
2	CONNECTOR	DB 15P FEMALE PIN G/F BLACK INSULATION SHELL Sn PLATED	1	SET
1	CABLE	UL20276 26AWG*15C+AL+D+PVC JACKET OD=6.2mm COLOR:BLACK (BH-201) VW-1	A/R	mm

THIS DRAWING IS A CONTROLLED DOCUMENT.		DWN GIRIDHAR, A 03MAY2024	TE Connectivity Ltd.	
DIMENSIONS: mm 		CHK WENKE HE 05MAY2024		
TOLERANCES UNLESS OTHERWISE SPECIFIED: 0 PLC ± - 1 PLC ± - 2 PLC ± - 3 PLC ± - 4 PLC ± - ANGLES ± -		APVD WENKE HE 05MAY2024	NAME DB 15P M TO F BLACK 5 FEET CABLE ASS'y	
MATERIAL		PRODUCT SPEC	RESTRICTED TO	
		APPLICATION SPEC	SIZE	CAGE CODE
		FINISH	DRAWING NO	
		WEIGHT	A3 00779 C-2478170	
		CUSTOMER DRAWING		SCALE 1:1
		SHEET 11 OF 26		REV A1

P	LTR	DESCRIPTION	DATE	DWN	APVD
-	-	SEE SHEET 1	-	-	-

AS SHOWN 1-2478170-3

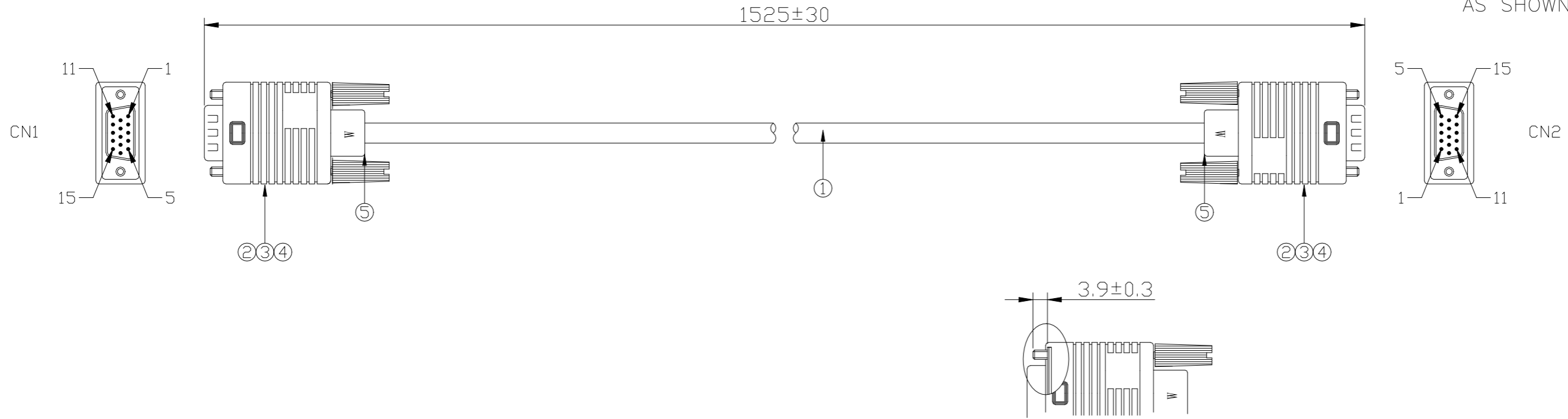

NOTES:
 1.ALL PRODUCTS 100% TEST OPEN,SHORT,MISS WIRE&INTERMITTENT TEST;
 2.INSULATION RESISTANCE:300V DC/0.01S/10MΩ
 3.DIELECTRIC STRENGTH:300V AC/0.01S/1mA
 4.RESISTANCE TEST: 2 Ω MAX.

WIRE CONNECTION

CN1	WIRE COLOR	CN2
1	RED	1
2	WHITE	2
3	DARK GREEN	3
4	BLACK	4
5	BROWN	5
6	PINK	6
7	LIGHT GREEN	7
8	GRAY	8
9	PURPLE	9
10	BLUE	10
11	RED & WHITE	11
12	ORANGE	12
13	YELLOW	13
14	BLACK & WHITE	14
15	BROWN & WHITE	15
SHELL	DRAIN	SHELL

ITEM	NAME	DESCRIPTION	Q'TY	UNIT
5	PVC	PVC BLACK(BH-201) 45P UL94V-0	A/R	KG
4	PE	PE NATURAL	A/R	KG
3	SCREW	#4-40 UNC NI PLATED MOLDED COLOR BLACK (BH-201)	4	PCS
2	CONNECTOR	DB 15P MALE PIN G/F BLACK INSULATION SHELL Sn PLATED	2	SET
1	CABLE	UL20276 26AWG*15C+AL+D+PVC JACKET OD=6.2mm COLOR:BLACK (BH-201) VW-1	A/R	mm

THIS DRAWING IS A CONTROLLED DOCUMENT.		DWN GIRIDHAR, A 03MAY2024	TE Connectivity Ltd.													
DIMENSIONS: mm		CHK WENKE HE 05MAY2024														
TOLERANCES UNLESS OTHERWISE SPECIFIED:		APVD WENKE HE 05MAY2024	NAME DB 9P M TO M BLACK 5 FEET CABLE ASS'y													
<table border="1"> <tr><td>0 PLC</td><td>± -</td></tr> <tr><td>1 PLC</td><td>± -</td></tr> <tr><td>2 PLC</td><td>± -</td></tr> <tr><td>3 PLC</td><td>± -</td></tr> <tr><td>4 PLC</td><td>± -</td></tr> <tr><td>ANGLES</td><td>± -</td></tr> </table>		0 PLC	± -	1 PLC	± -	2 PLC	± -	3 PLC	± -	4 PLC	± -	ANGLES	± -	PRODUCT SPEC -	-	
0 PLC	± -															
1 PLC	± -															
2 PLC	± -															
3 PLC	± -															
4 PLC	± -															
ANGLES	± -															
MATERIAL -		FINISH -	APPLICATION SPEC -	-												
		WEIGHT 0	SIZE A3	CAGE CODE 00779	DRAWING NO C-2478170											
CUSTOMER DRAWING			RESTRICTED TO -	SCALE 1:1	SHEET 12 OF 26											
			REV A1													

PACKAGE DETAILS : 2478170-1

REVISIONS

P	LTR	DESCRIPTION	DATE	DWN	APVD
-	-	SEE SHEET 1	-	-	-

PACKING MATERIAL

ITEM	P/N	DESCRIPTION	Q'TY
1		CARTON L:500*W:330*H:240mm B三B	1PCS
2		PE BAG L:500*W:330*H:450*T0.025mm	1PCS
3		ZIP BAG L:290*W:110*T:0.04mm WITH BLACK MARK	1PCS
4		MINI TIE L=140mm COLOR:BLACK	1PCS
5		TRANSPARENCE ADHESIVE TAPE W:48mm	2960mm
6		刀卡 L490*W220mmC二C	1PCS
7		刀卡 L320*W220mmC二C	1PCS

DESCRIPTION

1. ACCORDING TO THE DRAWING FOLD THE CABLE.
2. BIG PE-BAG MUST PUT IN CARTON AND COVER ALL PRODUCTS
3. ENVELOPE THE CARTON ADD PACKAGE.
4. UNIT: mm

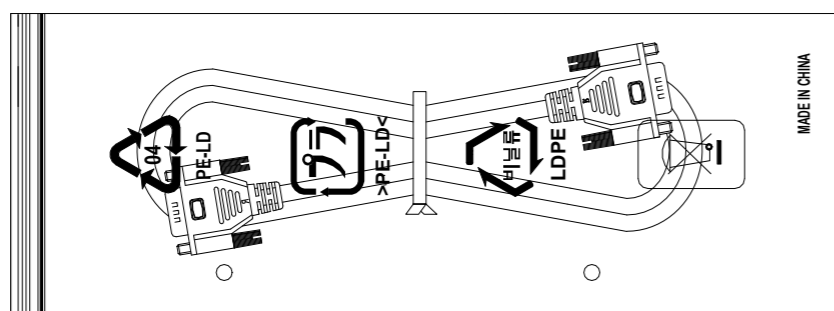
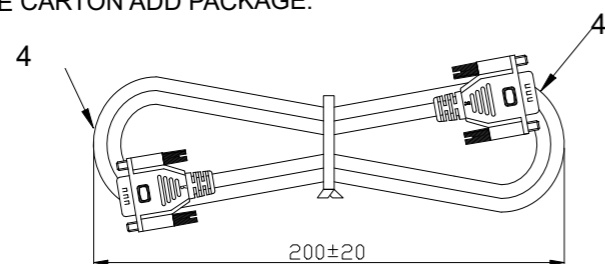

Q'TY : 120 PCS

N.W. : 11.64 KG/CTN (A1)

G.W. : 12.80 KG/CTN (A1)

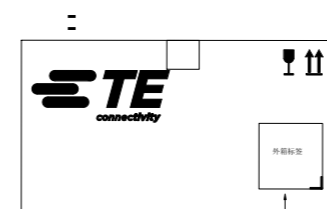

备注: 摆板时注意标签朝外摆放

Note: When placing the board, make sure that the label is facing outward

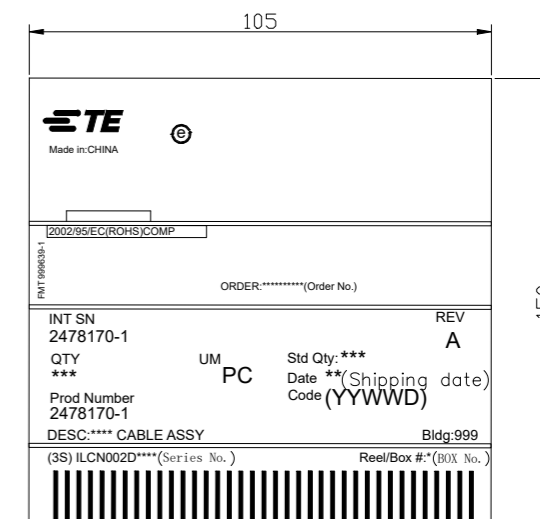

外箱标签

所有标签信息由业务提供

Carton label
All tag information is provided by the business

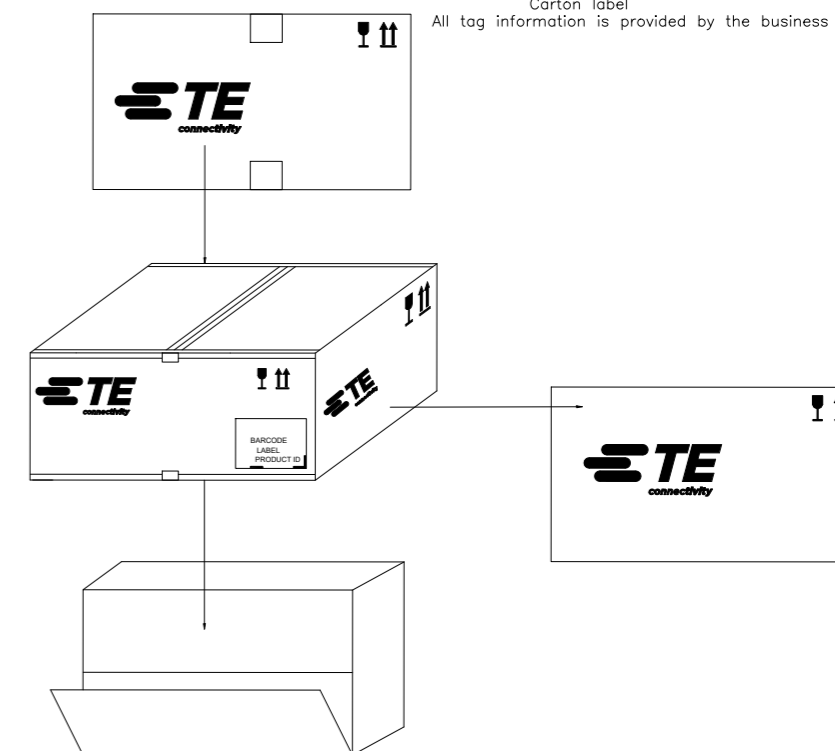
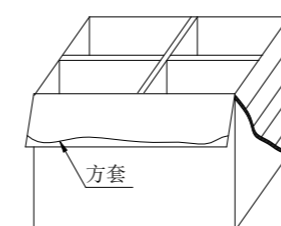

THIS DRAWING IS A CONTROLLED DOCUMENT.		DWN GIRIDHAR, A 03MAY2024	TE Connectivity Ltd.		
		CHK WENKE HE 05MAY2024			
		APVD WENKE HE 05MAY2024	NAME DB 9P M TO M BLACK 6 FEET CABLE ASS'y		
DIMENSIONS: mm		TOLERANCES UNLESS OTHERWISE SPECIFIED:		PRODUCT SPEC	
		0 PLC ± -		APPLICATION SPEC	
		1 PLC ± -		SIZE	
		2 PLC ± -		CAGE CODE	
		3 PLC ± -		DRAWING NO	
		4 PLC ± -		RESTRICTED TO	
		ANGLES ± -		A3 00779 C-2478170	
MATERIAL		FINISH		WEIGHT	
				0	
				CUSTOMER DRAWING	
				SCALE 1:1	
				SHEET 13 of 26	
				REV A1	

PACKAGE DETAILS : 2478170-2

REVISIONS

P	LTR	DESCRIPTION	DATE	DWN	APVD
-	-	SEE SHEET 1	-	-	-

PACKING MATERIAL

ITEM	P/N	DESCRIPTION	Q'TY
1		CARTON L:500*W:330*H:240mm B三B	1PCS
2		PE BAG L:500*W:330*H:450*T0.025mm	1PCS
3		ZIP BAG L:290*W:110*T:0.04mm WITH BLACK MARK	1PCS
4		MINI TIE L=140mm COLOR:BLACK	1PCS
5		TRANSPARENCE ADHESIVE TAPE W:48mm	2960mm
6		刀卡 L490*W220mmC二C	1PCS
7		刀卡 L320*W220mmC二C	1PCS

DESCRIPTION

1. ACCORDING TO THE DRAWING FOLD THE CABLE.
2. BIG PE-BAG MUST PUT IN CARTON AND COVER ALL PRODUCTS
3. ENVELOPE THE CARTON ADD PACKAGE.
4. UNIT: mm

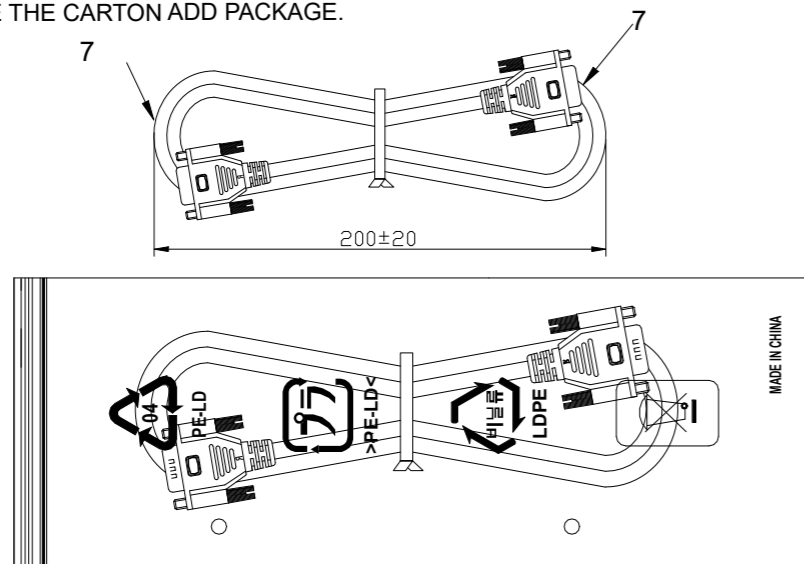

Q'TY : 80 PCS (A1)

N.W. : 11.20 KG/CTN (A1)

G.W. : 12.18 KG/CTN (A1)

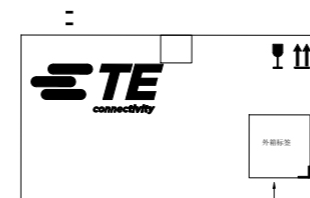

备注: 摆板时注意标签朝外摆放

Note: When placing the board, make sure that the label is facing outward

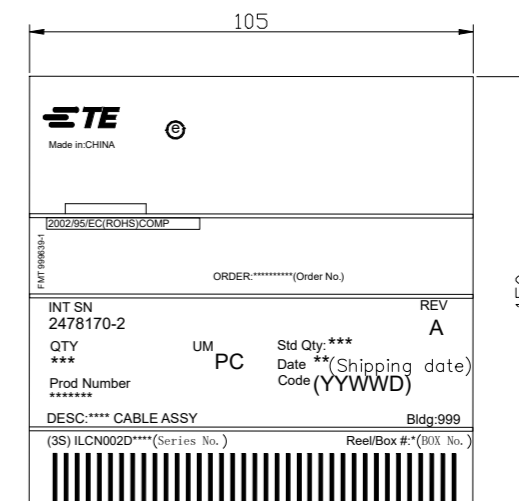

外箱标签

所有标签信息由业务提供

Carton label

All tag information is provided by the business

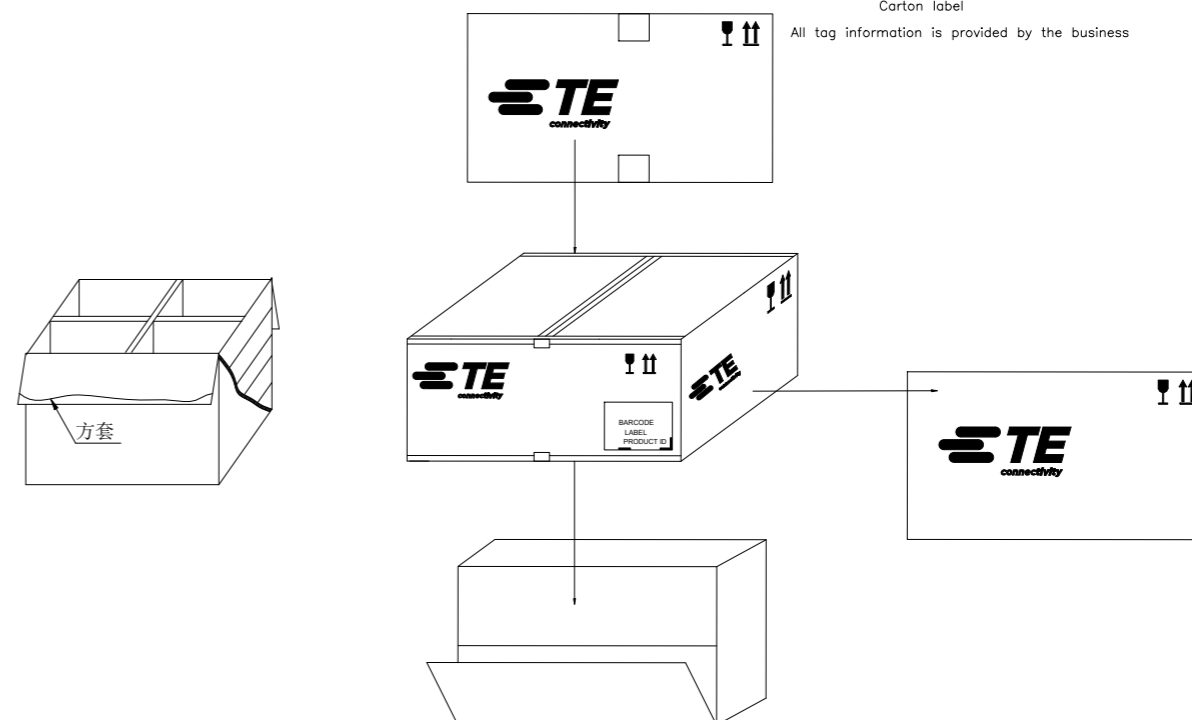

THIS DRAWING IS A CONTROLLED DOCUMENT.		DWN GIRIDHAR, A 03MAY2024	TE Connectivity Ltd.	
DIMENSIONS: mm		CHK WENKE HE 05MAY2024		
TOLERANCES UNLESS OTHERWISE SPECIFIED:		APVD WENKE HE 05MAY2024	NAME DB 9P M TO M BLACK 10 FEET CABLE ASS'y	
0 PLC ± -		PRODUCT SPEC	-	
1 PLC ± -		APPLICATION SPEC	-	
2 PLC ± -		WEIGHT 0	SIZE A3	RESTRICTED TO -
3 PLC ± -		CUSTOMER DRAWING	CAGE CODE 00779	DRAWING NO C-2478170
4 PLC ± -			SCALE 1:1	SHEET 14 OF 26
ANGLES ± -				
FINISH -				

PACKAGE DETAILS : 2478170-3

REVISIONS

P	LTR	DESCRIPTION	DATE	DWN	APVD
	-	SEE SHEET 1	-	-	-

PACKING MATERIAL

ITEM	P/N	DESCRIPTION	Q'TY
1		CARTON L:500*W:330*H:240mm B≡B	1PCS
2		PE BAG L:500*W:330*H:450*T0.025mm	1PCS
3		ZIP BAG L:290*W:110*T:0.04mm WITH BLACK MARK	1PCS
4		MINI TIE L=140mm COLOR:BLACK	1PCS
5		TRANSPARENCE ADHESIVE TAPE W:48mm	2960mm
6		刀卡 L490*W220mmC≡C	1PCS
7		刀卡 L320*W220mmC≡C	1PCS

DESCRIPTION

1. ACCORDING TO THE DRAWING FOLD THE CABLE.
2. BIG PE-BAG MUST PUT IN CARTON AND COVER ALL PRODUCTS
3. ENVELOPE THE CARTON ADD PACKAGE.
4. UNIT: mm

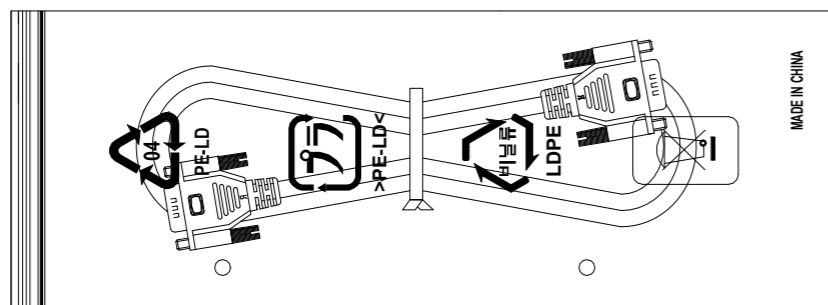
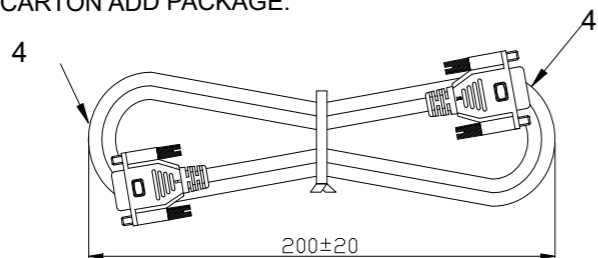

Q'TY : 120 PCS

N.W. : 11.76 KG/CTN (A1)

G.W. : 12.75 KG/CTN (A1)

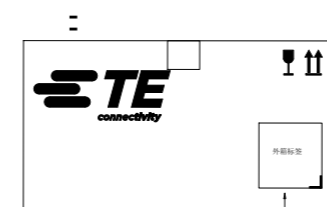

备注: 摆板时注意标签朝外摆放

Note: When placing the board, make sure that the label is facing outward

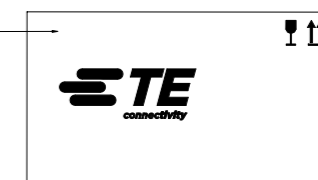
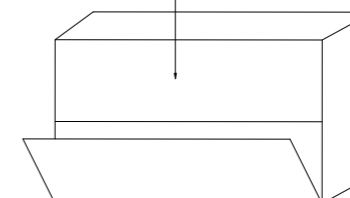
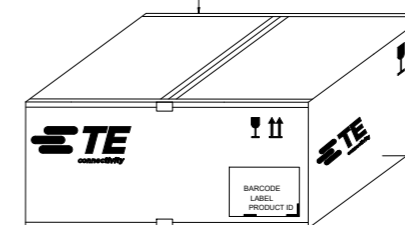
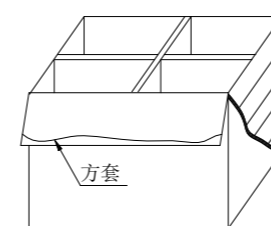
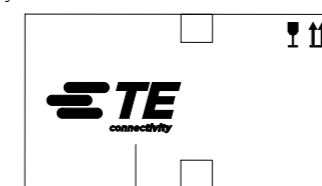

外箱标签
所有标签信息由业务提供
Carton label
All tag information is provided by the business

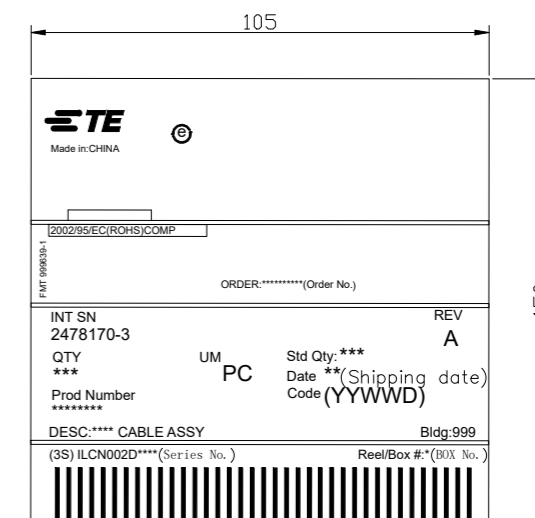

THIS DRAWING IS A CONTROLLED DOCUMENT.

DIMENSIONS:	TOLERANCES UNLESS OTHERWISE SPECIFIED:
mm	
	0 PLC ± -
	1 PLC ± -
	2 PLC ± -
	3 PLC ± -
	4 PLC ± -
	ANGLES ± -
MATERIAL	FINISH
-	-

DWN	GIRIDHAR, A	03MAY2024	TE Connectivity Ltd. DB 9P F TO F BLACK 6 FEET CABLE ASS'y					
CHK	WENKE HE	05MAY2024						
APVD	WENKE HE	05MAY2024						
PRODUCT SPEC	-							
APPLICATION SPEC	-		SIZE	CAGE CODE	DRAWING NO	RESTRICTED TO		
WEIGHT	0	A3	00779	C-2478170	-			
CUSTOMER DRAWING			SCALE	1:1	SHEET	15 of 26	REV	A1

PACKAGE DETAILS : 2478170-4

REVISIONS

P	LTR	DESCRIPTION	DATE	DWN	APVD
	-	SEE SHEET 1	-	-	-

PACKING MATERIAL

ITEM	P/N	DESCRIPTION	Q'TY
1		CARTON L:500*W:330*H:240mm B三B	1PCS
2		PE BAG L:500*W:330*H:450*T0.025mm	1PCS
3		ZIP BAG L:290*W:110*T:0.04mm WITH BLACK MARK	1PCS
4		MINI TIE L=140mm COLOR:BLACK	1PCS
5		TRANSPARENCE ADHESIVE TAPE W:48mm	2960mm
6		刀卡 L490*W220mmC二C	1PCS
7		刀卡 L320*W220mmC二C	1PCS

DESCRIPTION

1. ACCORDING TO THE DRAWING FOLD THE CABLE.
2. BIG PE-BAG MUST PUT IN CARTON AND COVER ALL PRODUCTS
3. ENVELOPE THE CARTON ADD PACKAGE.
4. UNIT: mm
4. UNIT: mm

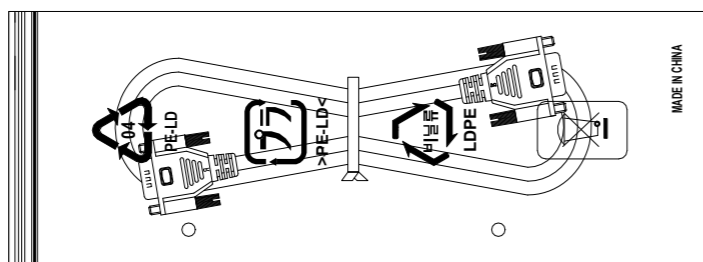
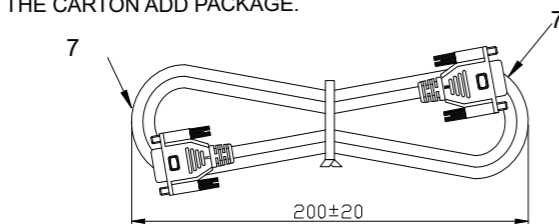

Q'TY : 80 PCS (A1)

N.W. : 11.2 KG/CTN (A1)

G.W. : 12.18 KG/CTN (A1)

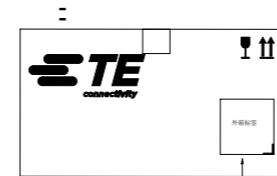

备注: 摆板时注意标签朝外摆放
 Note: When placing the board, make sure that the label is facing outward

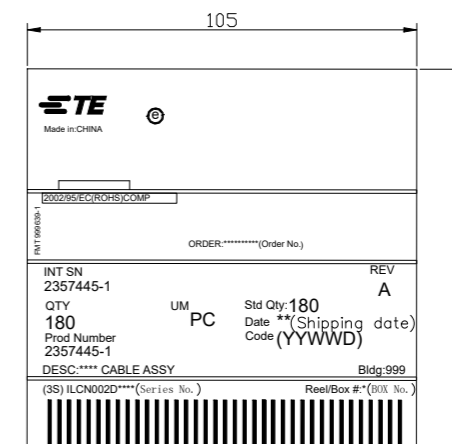

外箱标签
 所有标签信息由业务提供
 Carton label
 All tag information is provided by the business

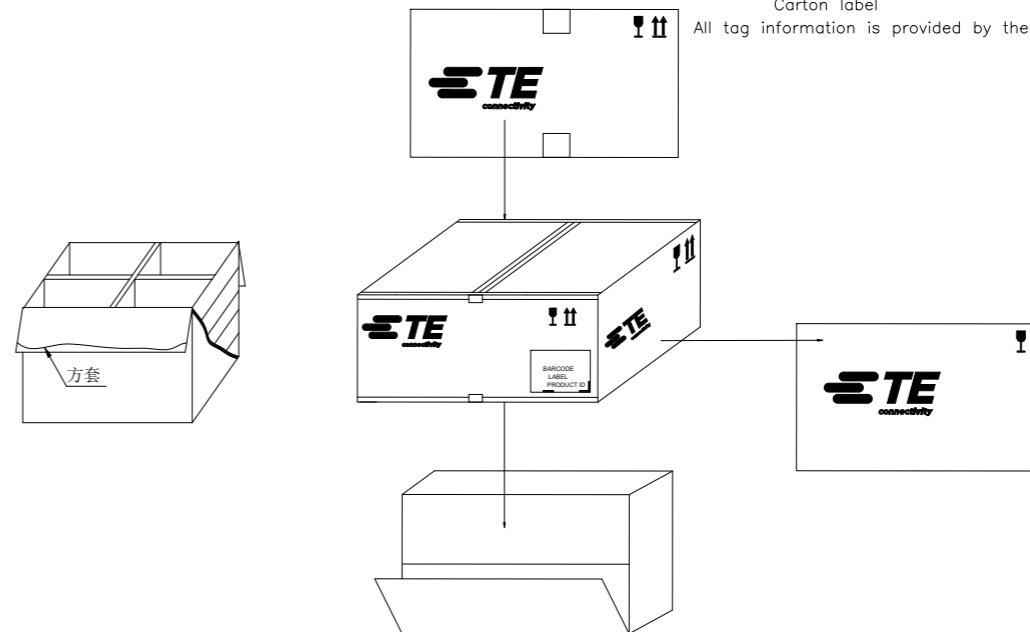

THIS DRAWING IS A CONTROLLED DOCUMENT.		DWN GIRIDHAR, A 03MAY2024	TE Connectivity Ltd.		
		CHK WENKE HE 05MAY2024			
		APVD WENKE HE 05MAY2024	NAME DB 9P F TO F BLACK 10 FEET CABLE ASS'y		
DIMENSIONS: mm		TOLERANCES UNLESS OTHERWISE SPECIFIED:		PRODUCT SPEC	
		0 PLC ± -		APPLICATION SPEC	
		1 PLC ± -		-	
		2 PLC ± -		-	
		3 PLC ± -		-	
MATERIAL		FINISH		WEIGHT	
-		-		0	
				SIZE	RESTRICTED TO
				A3 00779	-
				CAGE CODE	DRAWING NO
				G-2478170	-
				SCALE	SHEET
				1:1	16 OF 26
				REV	A1
				CUSTOMER DRAWING	

PACKAGE DETAILS : 2478170-5

REVISIONS

P	LTR	DESCRIPTION	DATE	DWN	APVD
	-	SEE SHEET 1	-	-	-

PACKING MATERIAL

ITEM	P/N	DESCRIPTION	Q'TY
1		CARTON L:500*W:330*H:240mm B三B	1PCS
2		PE BAG L:500*W:330*H:450*T0.025mm	1PCS
3		ZIP BAG L:290*W:110*T:0.04mm WITH BLACK MARK	1PCS
4		MINI TIE L=140mm COLOR:BLACK	1PCS
5		TRANSPARENCE ADHESIVE TAPE W:48mm	2960mm
6		刀卡 L490*W220mmC二C	1PCS
7		刀卡 L320*W220mmC二C	1PCS

DESCRIPTION

1. ACCORDING TO THE DRAWING FOLD THE CABLE.
2. BIG PE-BAG MUST PUT IN CARTON AND COVER ALL PRODUCTS
3. ENVELOPE THE CARTON ADD PACKAGE.
4. UNIT: mm

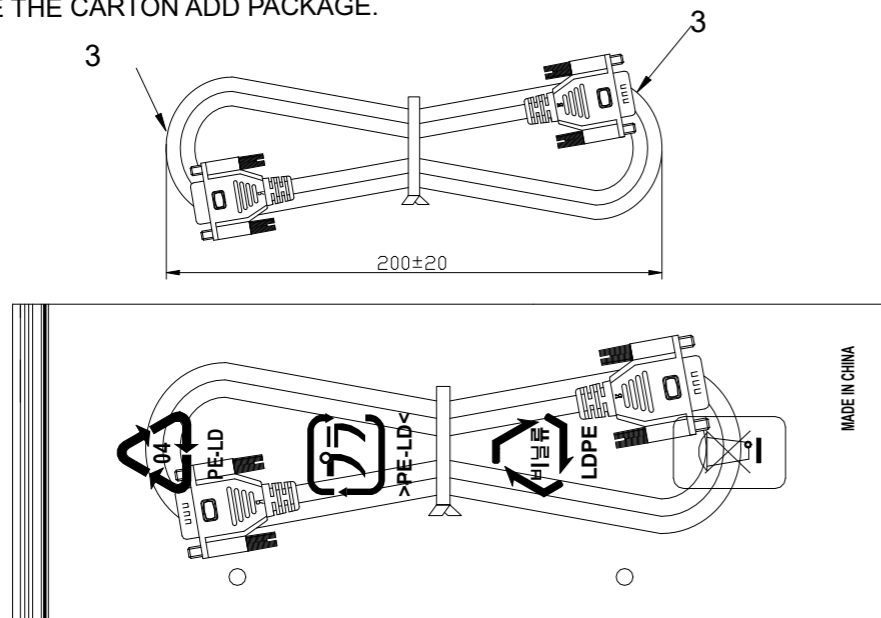

Q'TY : 120 PCS (A1)

N.W. : 12.98 KG/CTN (A1)

G.W. : 13.92 KG/CTN (A1)

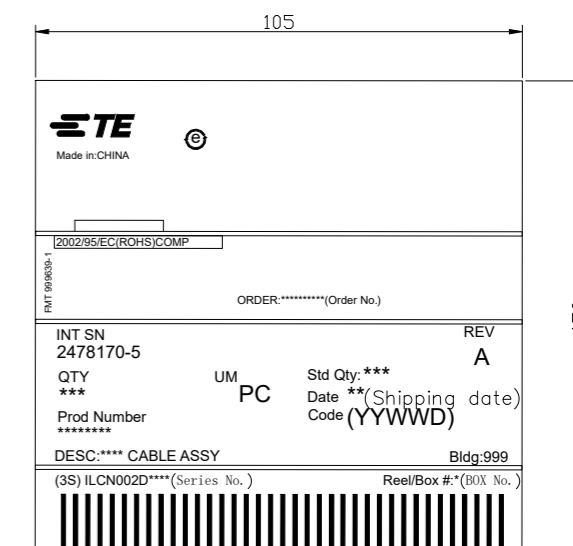
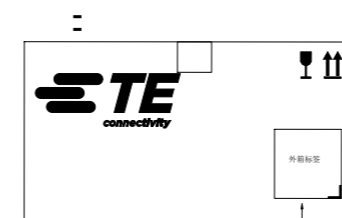

备注: 摆板时注意标签朝外摆放

Note: When placing the board, make sure that the label is facing outward

外箱标签

所有标签信息由业务提供

Carton label
All tag information is provided by the business

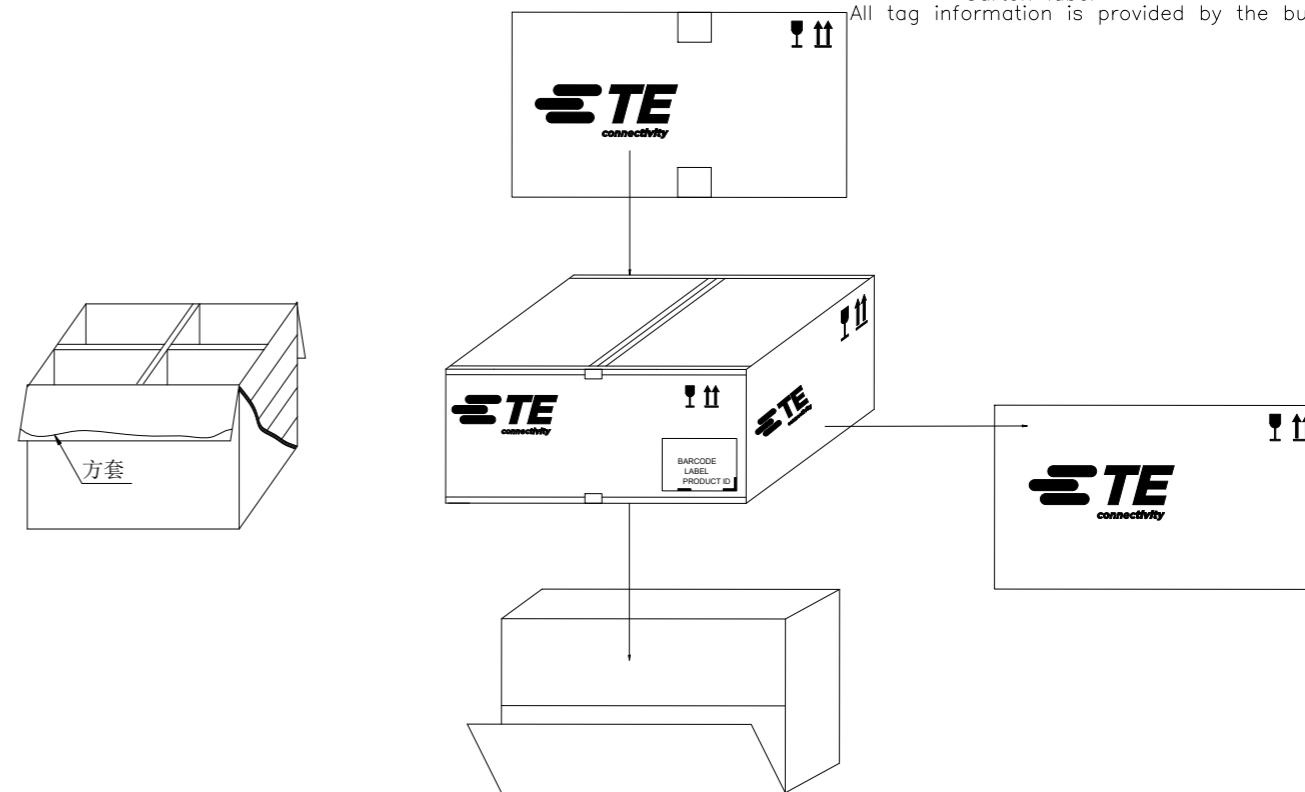

THIS DRAWING IS A CONTROLLED DOCUMENT.

DIMENSIONS:	TOLERANCES UNLESS OTHERWISE SPECIFIED:
mm	
	0 PLC ± -
	1 PLC ± -
	2 PLC ± -
	3 PLC ± -
	4 PLC ± -
	ANGLES ± -
MATERIAL	FINISH
-	-

DWN	GIRIDHAR, A	03MAY2024
CHK	WENKE HE	05MAY2024
APVD	WENKE HE	05MAY2024
PRODUCT SPEC	-	
APPLICATION SPEC	-	
WEIGHT	0	
CUSTOMER DRAWING		

TE TE Connectivity Ltd.			
NAME: DB 9P M TO F BLACK 5 FEET CABLE ASS'y			
SIZE	CAGE CODE	DRAWING NO	RESTRICTED TO
A3	00779	C-2478170	-
SCALE: 1:1		SHEET: 17 of 26	REV: A1

PACKAGE DETAILS : 2478170-6

REVISIONS

P	LTR	DESCRIPTION	DATE	DWN	APVD
-	-	SEE SHEET 1	-	-	-

PACKING MATERIAL

ITEM	P/N	DESCRIPTION	Q'TY
1		CARTON L:500*W:330*H:240mm B≡B	1PCS
2		PE BAG L:500*W:330*H:450*T0.025mm	1PCS
3		ZIP BAG L:290*W:110*T:0.04mm WITH BLACK MARK	1PCS
4		MINI TIE L=140mm COLOR:BLACK	1PCS
5		TRANSPARENCE ADHESIVE TAPE W:48mm	2960mm
6		刀卡 L490*W220mmC二C	1PCS
7		刀卡 L320*W220mmC二C	1PCS

DESCRIPTION

1. ACCORDING TO THE DRAWING FOLD THE CABLE.
2. BIG PE-BAG MUST PUT IN CARTON AND COVER ALL PRODUCTS
3. ENVELOPE THE CARTON ADD PACKAGE.
4. UNIT: mm

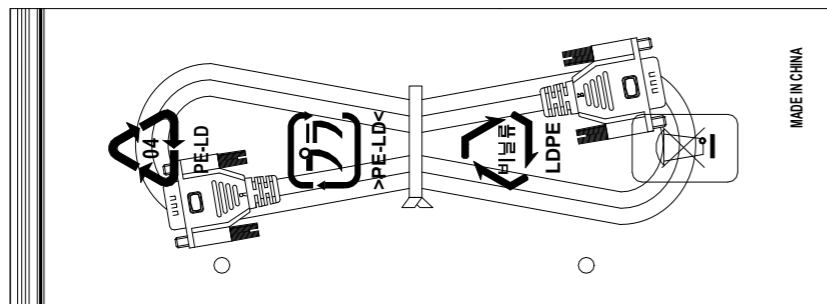
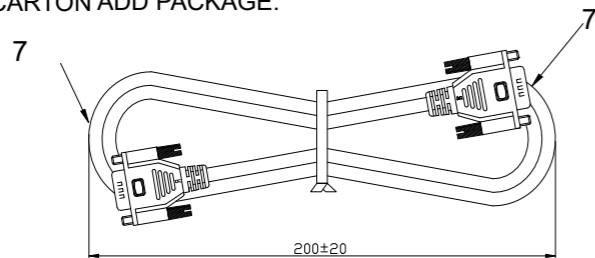

Q'TY : 80 PCS (A1)

N.W. : 14.27 KG/CTN (A1)

G.W. : 15.28 KG/CTN (A1)

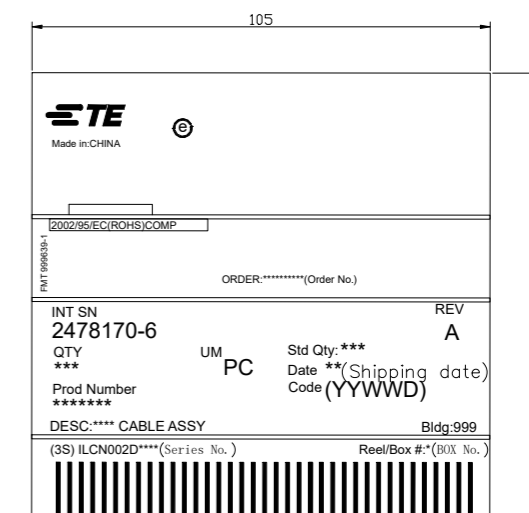
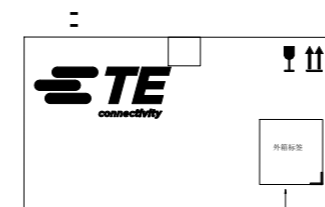

备注: 摆板时注意标签朝外摆放
 Note: When placing the board, make sure that the label is facing outward

外箱标签
 所有标签信息由业务提供
 Carton label
 All tag information is provided by the business

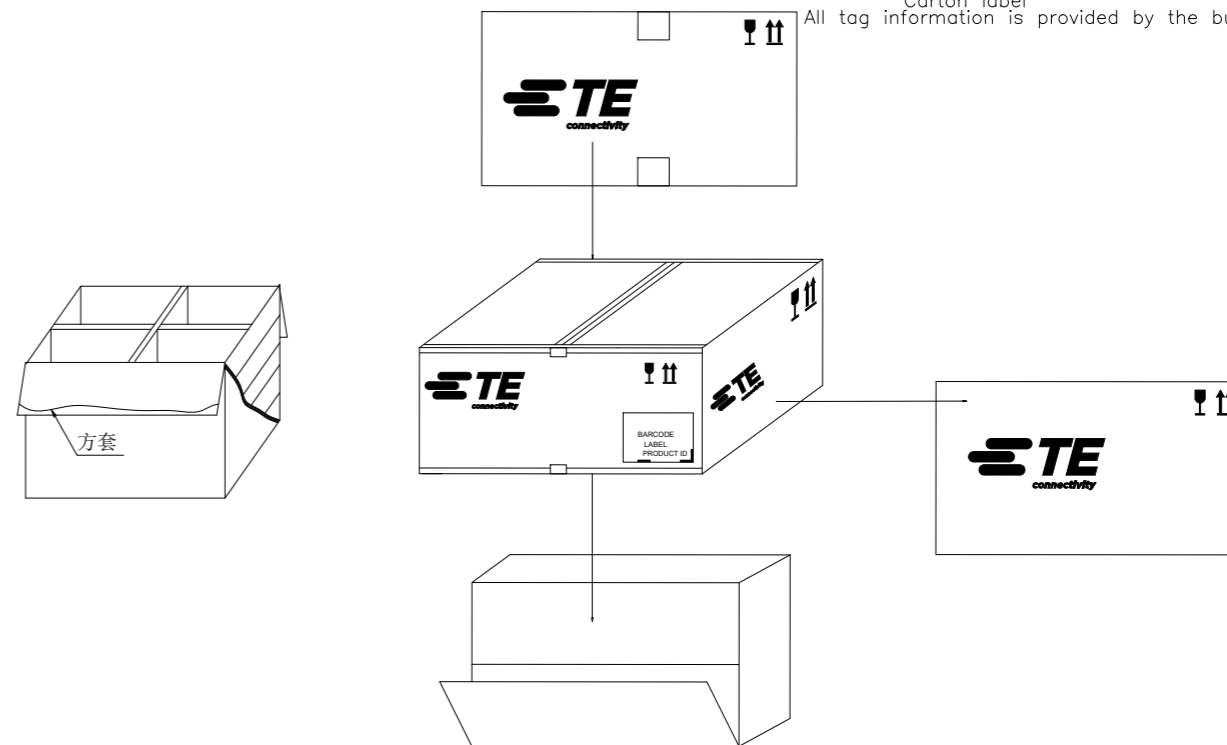

THIS DRAWING IS A CONTROLLED DOCUMENT.

DIMENSIONS:	TOLERANCES UNLESS OTHERWISE SPECIFIED:
mm	
	0 PLC ± -
	1 PLC ± -
	2 PLC ± -
	3 PLC ± -
	4 PLC ± -
	ANGLES ± -
MATERIAL	FINISH
-	-

DWN	GIRIDHAR, A	03MAY2024
CHK	WENKE HE	05MAY2024
APVD	WENKE HE	05MAY2024
PRODUCT SPEC	-	
APPLICATION SPEC	-	
WEIGHT	0	
CUSTOMER DRAWING		

STE TE Connectivity Ltd.			
NAME DB 9P M TO F BLACK 10 FEET CABLE ASS'y			
SIZE	CAGE CODE	DRAWING NO	RESTRICTED TO
A3	00779	C-2478170	-
SCALE		SHEET	REV
1:1		18 of 26	A1

PACKAGE DETAILS : 2478170-7

REVISIONS

P	LTR	DESCRIPTION	DATE	DWN	APVD
-	-	SEE SHEET 1	-	-	-

PACKING MATERIAL

ITEM	P/N	DESCRIPTION	Q'TY
1		CARTON L:500*W:330*H:240mm B三B	1PCS
2		PE BAG L:500*W:330*H:450*T0.025mm	1PCS
3		ZIP BAG L:290*W:110*T:0.04mm WITH BLACK MARK	1PCS
4		MINI TIE L=140mm COLOR:BLACK	1PCS
5		TRANSPARENCE ADHESIVE TAPE W:48mm	2960mm
6		刀卡 L490*W220mmC二C	1PCS
7		刀卡 L320*W220mmC二C	1PCS

DESCRIPTION

1. ACCORDING TO THE DRAWING FOLD THE CABLE.
2. BIG PE-BAG MUST PUT IN CARTON AND COVER ALL PRODUCTS
3. ENVELOPE THE CARTON ADD PACKAGE.
4. UNIT: mm

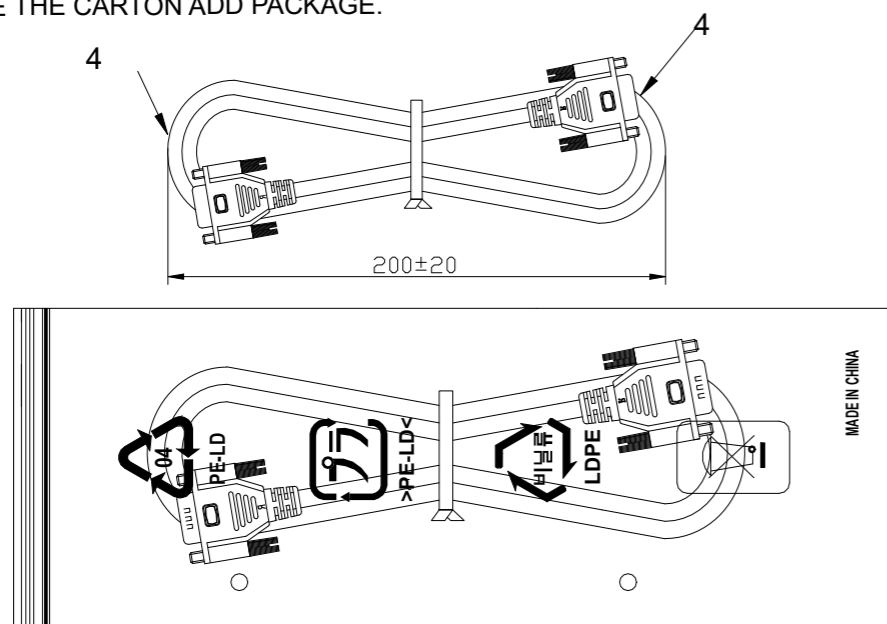

Q'TY : 120 PCS

N.W. : 14.46 KG/CTN (A1)

G.W. : 15.50 KG/CTN (A1)

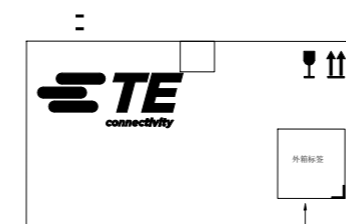

备注: 摆板时注意标签朝外摆放

Note: When placing the board, make sure that the label is facing outward

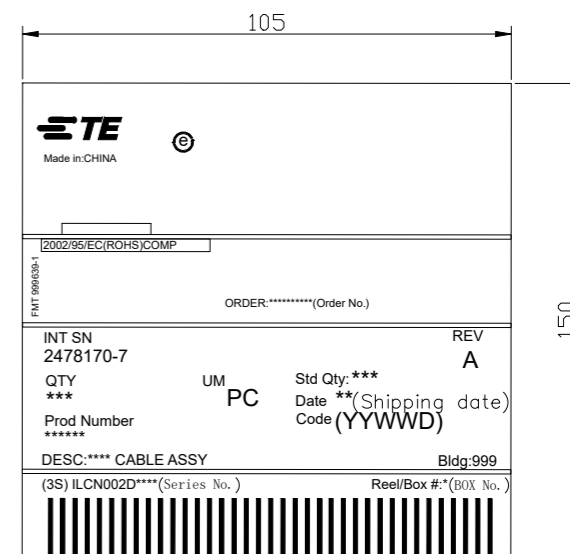

外箱标签

所有标签信息由业务提供

Carton label
All tag information is provided by the business

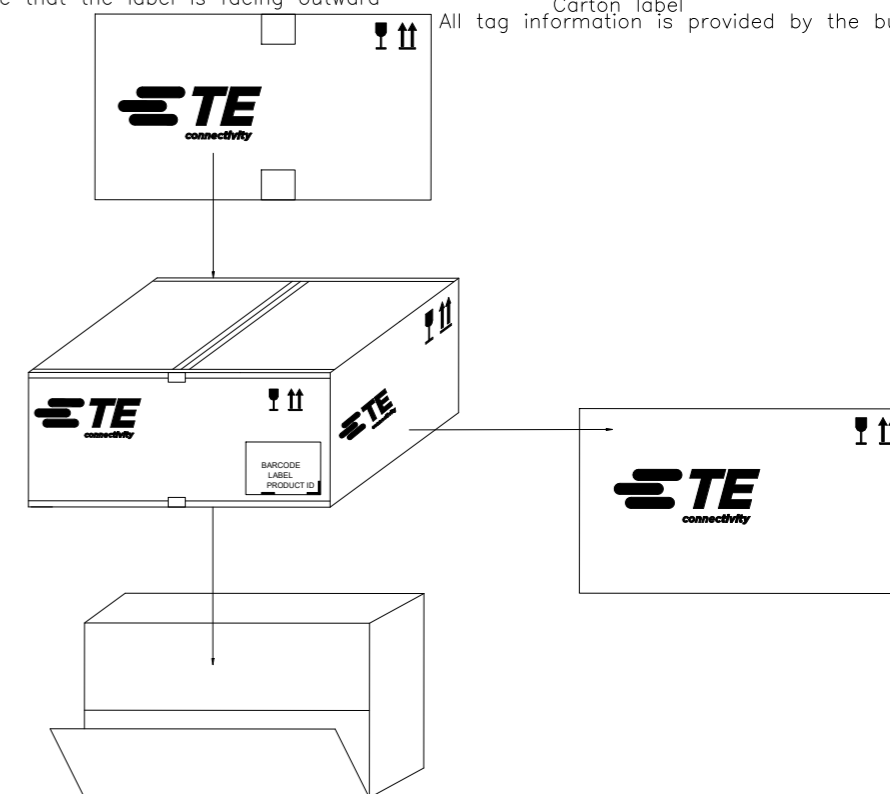
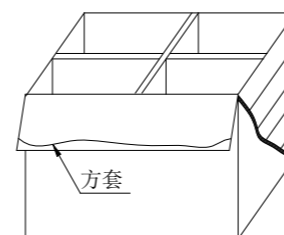

THIS DRAWING IS A CONTROLLED DOCUMENT.

DIMENSIONS:	TOLERANCES UNLESS OTHERWISE SPECIFIED:
mm	
	0 PLC ± -
	1 PLC ± -
	2 PLC ± -
	3 PLC ± -
	4 PLC ± -
	ANGLES ± -
MATERIAL	FINISH
-	-

DWN	GIRIDHAR, A	03MAY2024
CHK	WENKE HE	05MAY2024
APVD	WENKE HE	05MAY2024
PRODUCT SPEC	-	
APPLICATION SPEC	-	
WEIGHT	0	
CUSTOMER DRAWING		

TE TE Connectivity Ltd.			
NAME: DB 9P M TO F BLACK 6 FEET CABLE ASS'y			
SIZE	CAGE CODE	DRAWING NO	RESTRICTED TO
A3	00779	C-2478170	-
SCALE: 1:1		SHEET: 19 of 26	REV: A1

PACKAGE DETAILS : 2478170-8

REVISIONS

P	LTR	DESCRIPTION	DATE	DWN	APVD
-	-	SEE SHEET 1	-	-	-

PACKING MATERIAL

ITEM	P/N	DESCRIPTION	Q'TY
1		CARTON L:500*W:330*H:240mm B三B	1PCS
2		PE BAG L:500*W:330*H:450*T0.025mm	1PCS
3		ZIP BAG L:290*W:110*T:0.04mm WITH BLACK MARK	1PCS
4		MINI TIE L=140mm COLOR:BLACK	1PCS
5		TRANSPARENCE ADHESIVE TAPE W:48mm	2960mm
6		刀卡 L490*W220mmC二C	1PCS
7		刀卡 L320*W220mmC二C	1PCS

DESCRIPTION

1. ACCORDING TO THE DRAWING FOLD THE CABLE.
2. BIG PE-BAG MUST PUT IN CARTON AND COVER ALL PRODUCTS
3. ENVELOPE THE CARTON ADD PACKAGE.
4. UNIT: mm

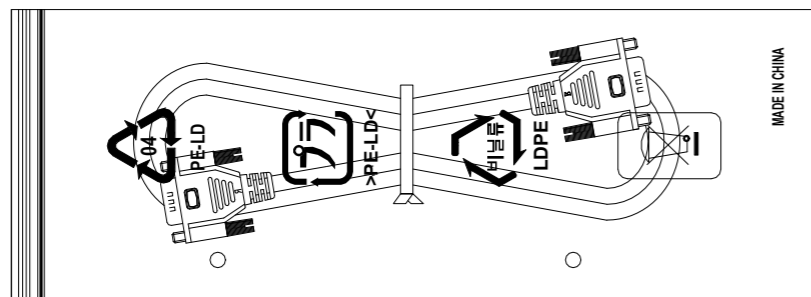
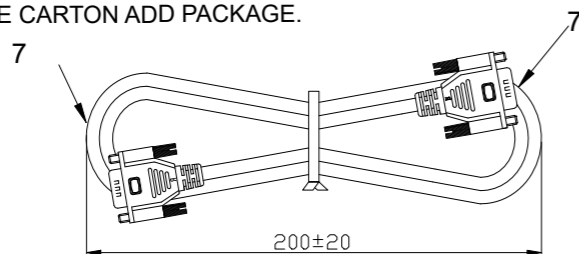

Q'TY : 80 PCS (A1)

N.W. : 11.20 KG/CTN (A1)

G.W. : 12.17 KG/CTN (A1)

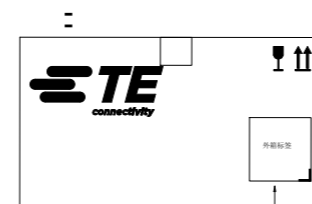

备注: 摆板时注意标签朝外摆放

Note: When placing the board, make sure that the label is facing outward

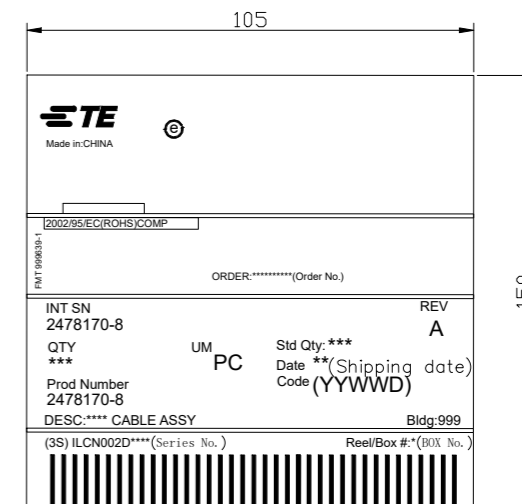

外箱标签

所有标签信息由业务提供

Carton label
All tag information is provided by the business

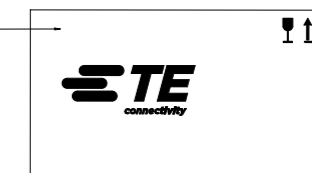
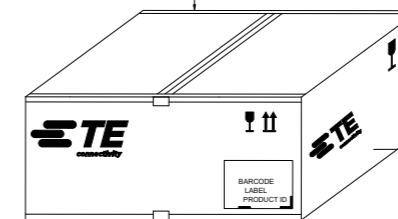
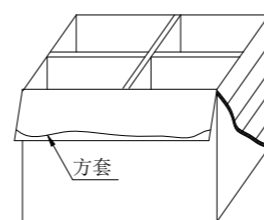

THIS DRAWING IS A CONTROLLED DOCUMENT.

DIMENSIONS:	TOLERANCES UNLESS OTHERWISE SPECIFIED:
mm	
	0 PLC ± -
	1 PLC ± -
	2 PLC ± -
	3 PLC ± -
	4 PLC ± -
	ANGLES ± -
MATERIAL	FINISH
-	-

DWN	GIRIDHAR, A	03MAY2024
CHK	WENKE HE	05MAY2024
APVD	WENKE HE	05MAY2024
PRODUCT SPEC	-	
APPLICATION SPEC	-	
WEIGHT	0	
CUSTOMER DRAWING		

		TE Connectivity Ltd.	
		NAME	
DB 9P M TO F BLACK 10 FEET CABLE ASS'y		RESTRICTED TO	
SIZE	CAGE CODE	DRAWING NO	
A3	00779	C-2478170	
SCALE		SHEET	REV
1:1		20 OF 26	A1

PACKAGE DETAILS : 2478170-9

REVISIONS

P	LTR	DESCRIPTION	DATE	DWN	APVD
	-	SEE SHEET 1	-	-	-

PACKING MATERIAL

ITEM	P/N	DESCRIPTION	Q'TY
1		CARTON L:500*W:330*H:240mm B三B	1PCS
2		PE BAG L:500*W:330*H:450*T0.025mm	1PCS
3		ZIP BAG L:290*W:110*T:0.04mm WITH BLACK MARK	1PCS
4		MINI TIE L=140mm COLOR:BLACK	1PCS
5		TRANSPARENCE ADHESIVE TAPE W:48mm	2960mm
6		珍珠棉 L50*W165*T0.1mm	400PCS
7		TRANSPARENCE ADHESIVE TAPE W:10mm	mm
8		刀卡 L490*W220mmC二C	1PCS
9		刀卡 L320*W220mmC二C	1PCS

DESCRIPTION

1. ACCORDING TO THE DRAWING FOLD THE CABLE.
2. BIG PE-BAG MUST PUT IN CARTON AND COVER ALL PRODUCTS
3. ENVELOPE THE CARTON ADD PACKAGE.
4. UNIT: mm

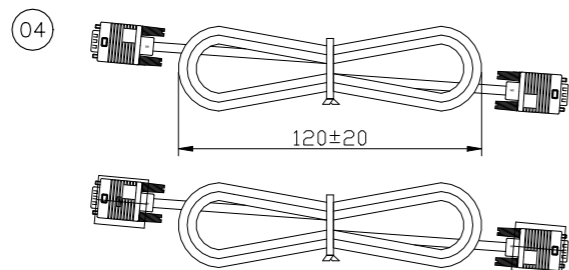

Q'TY : 136 PCS (A1)

N.W. : 14.41 KG/CTN (A1)

G.W. : 15.30 KG/CTN (A1)

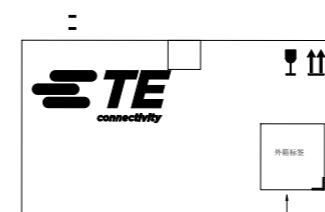

备注: 摆板时注意标签朝外摆放

Note: When placing the board, make sure that the label is facing outward

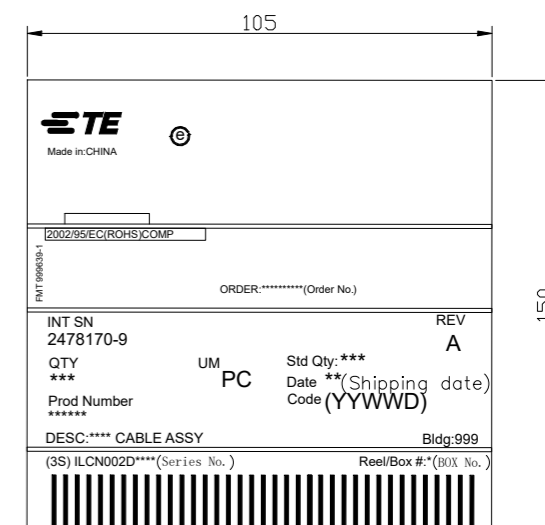

外箱标签

所有标签信息由业务提供
Carton label

All tag information is provided by the business

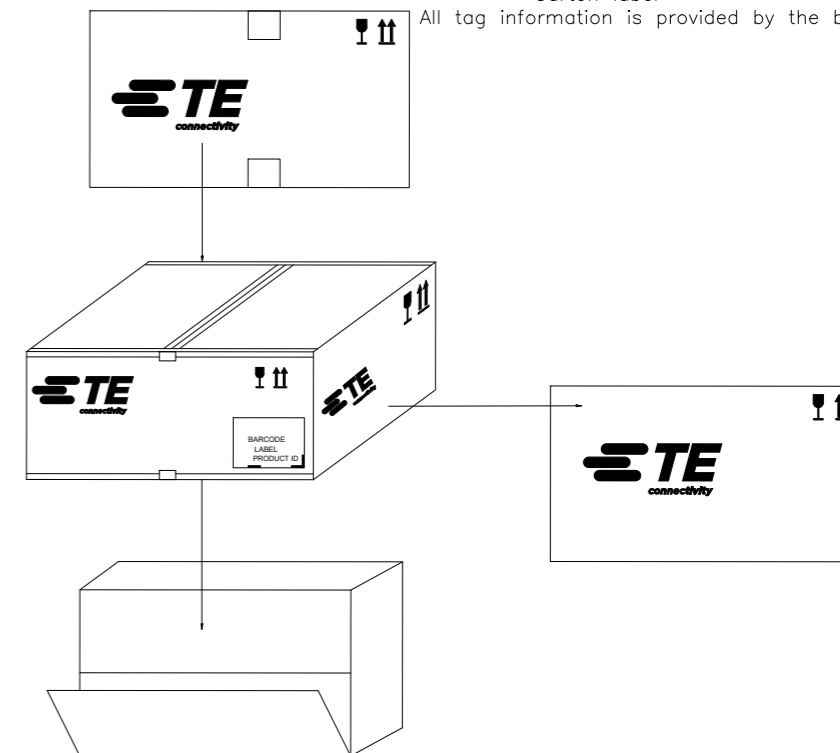
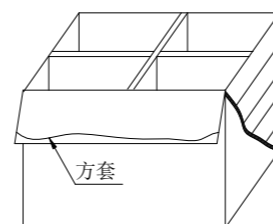

THIS DRAWING IS A CONTROLLED DOCUMENT.

DIMENSIONS:	TOLERANCES UNLESS OTHERWISE SPECIFIED:
mm	
	0 PLC ± -
	1 PLC ± -
	2 PLC ± -
	3 PLC ± -
	4 PLC ± -
	ANGLES ± -
MATERIAL	FINISH
-	-

DWN	GIRIDHAR, A	03MAY2024
CHK	WENKE HE	05MAY2024
APVD	WENKE HE	05MAY2024
PRODUCT SPEC	-	
APPLICATION SPEC	-	
WEIGHT	0	
CUSTOMER DRAWING		

TE TE Connectivity Ltd.

NAME: DB 15P M TO M BLACK 2.5 FEET CABLE ASS'y

SIZE	CAGE CODE	DRAWING NO	RESTRICTED TO
A3	00779	C-2478170	-
SCALE 1:1		SHEET 21 of 26	REV A1

PACKAGE DETAILS : 1- 2478170-1

REVISIONS

P	LTR	DESCRIPTION	DATE	DWN	APVD
-	-	SEE SHEET 1	-	-	-

PACKING MATERIAL

ITEM	P/N	DESCRIPTION	Q'TY
1		CARTON L:500*W:330*H:240mm B三B	1PCS
2		PE BAG L:500*W:330*H:450*T0.025mm	1PCS
3		ZIP BAG L:290*W:110*T:0.04mm WITH BLACK MARK	1PCS
4		MINI TIE L=140mm COLOR:BLACK	1PCS
5		TRANSPARENCE ADHESIVE TAPE W:48mm	2960mm
6		珍珠棉 L50*W165*T0.1mm	400PCS
7		TRANSPARENCE ADHESIVE TAPE W:10mm	mm
8		刀卡 L490*W220mmC二C	1PCS
9		刀卡 L320*W220mmC二C	1PCS

DESCRIPTION

1. ACCORDING TO THE DRAWING FOLD THE CABLE.
2. BIG PE-BAG MUST PUT IN CARTON AND COVER ALL PRODUCTS
3. ENVELOPE THE CARTON ADD PACKAGE.
4. UNIT: mm

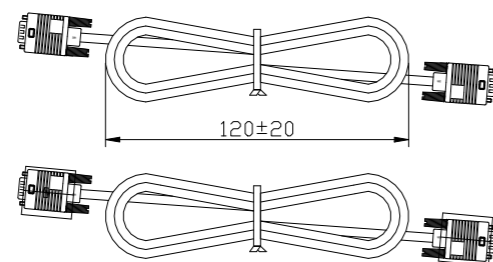

Q'TY : 136 PCS (A1)

N.W. : 14.41 KG/CTN (A1)

G.W. : 15.3 KG/CTN (A1)

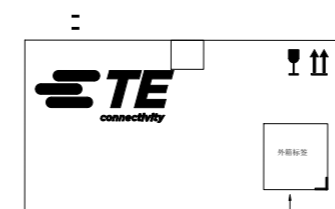

备注: 摆板时注意标签朝外摆放
 Note: When placing the board, make sure that the label is facing outward

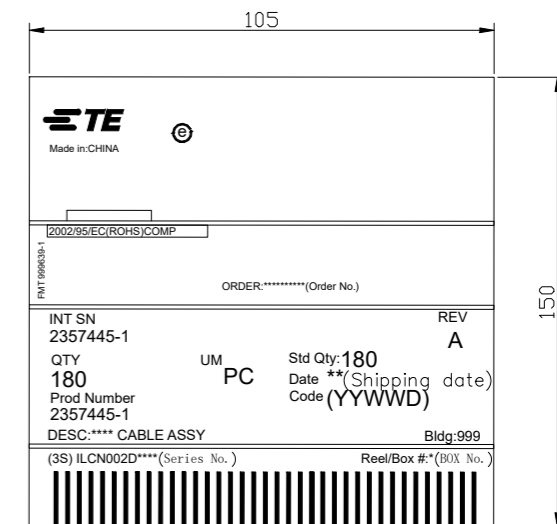
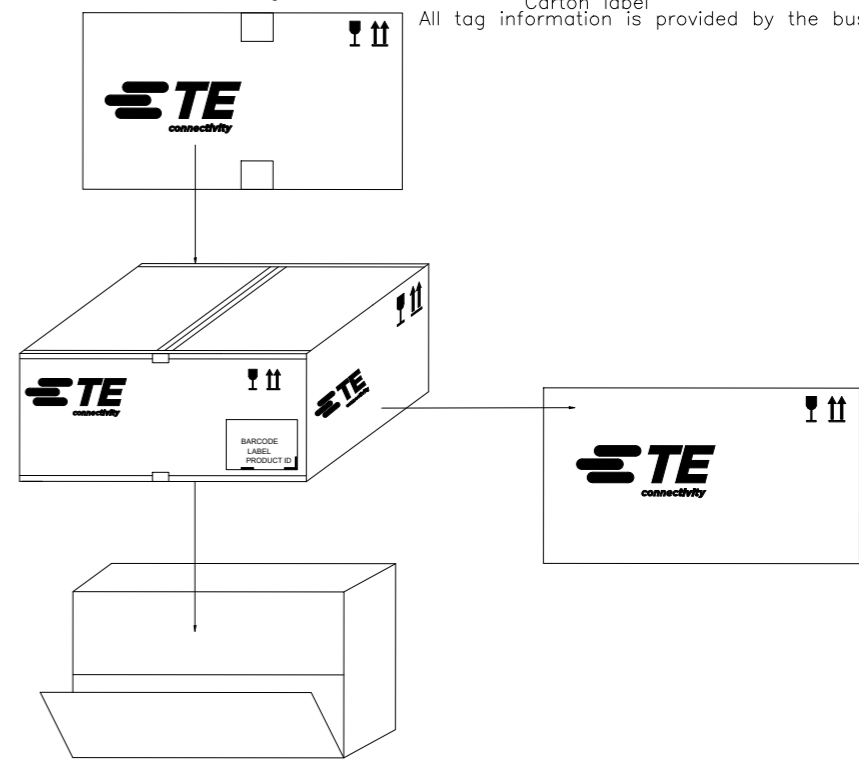
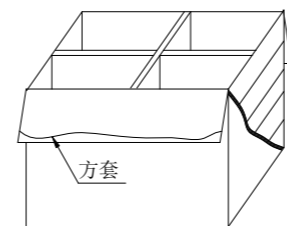

外箱标签
 所有标签信息由业务提供
 Carton label
 All tag information is provided by the business

THIS DRAWING IS A CONTROLLED DOCUMENT.		DWN GIRIDHAR, A 03MAY2024		TE Connectivity Ltd.	
DIMENSIONS: mm		CHK WENKE HE 05MAY2024			
TOLERANCES UNLESS OTHERWISE SPECIFIED:		APVD WENKE HE 05MAY2024		NAME DB 9P M TO F BLACK 2.5 FEET CABLE ASS'y	
0 PLC ± -		PRODUCT SPEC -		APPLICATION SPEC -	
1 PLC ± -		WEIGHT 0		SIZE A3	
2 PLC ± -		CAGE CODE 00779		DRAWING NO C-2478170	
3 PLC ± -		RESTRICTED TO -		SCALE 1:1	
4 PLC ± -		CUSTOMER DRAWING		SHEET 22 OF 26	
ANGLES ± -		FINISH -		REV A1	
MATERIAL -					

PACKAGE DETAILS : 1- 2478170-2

REVISIONS

P	LTR	DESCRIPTION	DATE	DWN	APVD
-	-	SEE SHEET 1	-	-	-

PACKING MATERIAL

ITEM	P/N	DESCRIPTION	Q'TY
1		CARTON L:500*W:330*H:240mm B三B	1PCS
2		PE BAG L:500*W:330*H:450*T0.025mm	1PCS
3		ZIP BAG L:290*W:110*T:0.04mm WITH BLACK MARK	1PCS
4		MINI TIE L=140mm COLOR:BLACK	1PCS
5		TRANSPARENCE ADHESIVE TAPE W:48mm	2960mm
6		刀卡 L490*W220mmC二C	1PCS
7		刀卡 L320*W220mmC二C	1PCS

DESCRIPTION

1. ACCORDING TO THE DRAWING FOLD THE CABLE.
2. BIG PE-BAG MUST PUT IN CARTON AND COVER ALL PRODUCTS
3. ENVELOPE THE CARTON ADD PACKAGE.
4. UNIT: mm

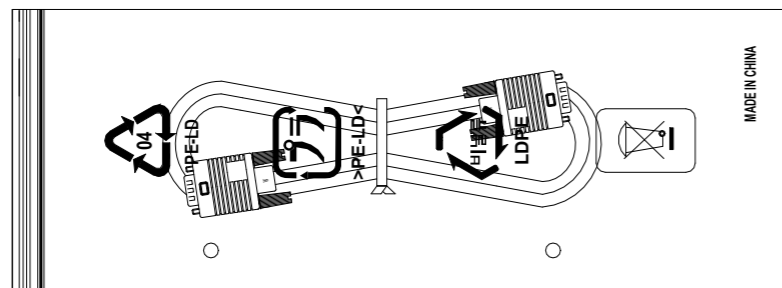
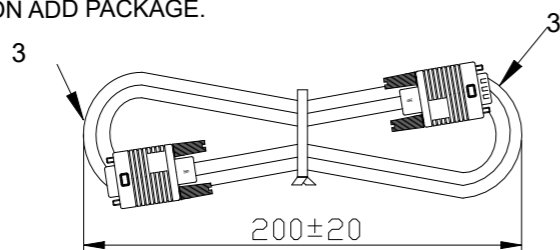

Q'TY : 92 PCS (A1)

N.W. : 13.8 KG/CTN (A1)

G.W. : 14.9 KG/CTN (A1)

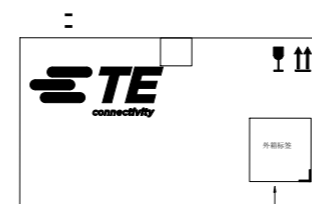

备注: 摆板时注意标签朝外摆放
 Note: When placing the board, make sure that the label is facing outward

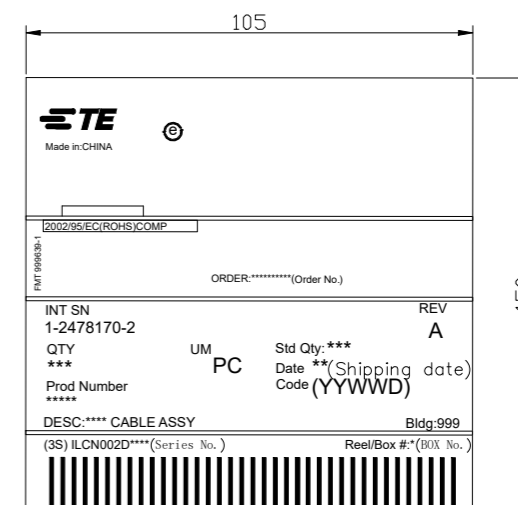

外箱标签
 所有标签信息由业务提供
 Carton label
 All tag information is provided by the business

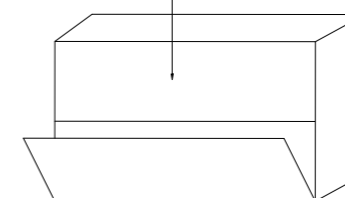
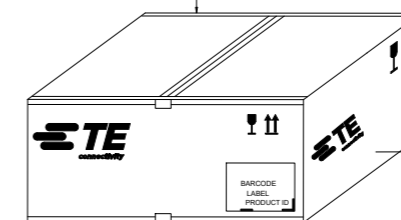
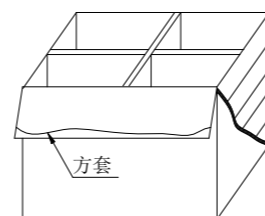

THIS DRAWING IS A CONTROLLED DOCUMENT.

DIMENSIONS:	TOLERANCES UNLESS OTHERWISE SPECIFIED:
mm	
	0 PLC ± -
	1 PLC ± -
	2 PLC ± -
	3 PLC ± -
	4 PLC ± -
	ANGLES ± -
MATERIAL	FINISH
-	-

DWN	GIRIDHAR, A	03MAY2024
CHK	WENKE HE	05MAY2024
APVD	WENKE HE	05MAY2024
PRODUCT SPEC	-	
APPLICATION SPEC	-	
WEIGHT	0	
CUSTOMER DRAWING		

STE TE Connectivity Ltd.			
NAME DB 15P M TO F BLACK 5 FEET CABLE ASS'y			
SIZE	CAGE CODE	DRAWING NO	RESTRICTED TO
A3	00779	C-2478170	-
SCALE 1:1		SHEET 23 OF 26	REV A1

PACKAGE DETAILS : 1- 2478170-3

REVISIONS

P	LTR	DESCRIPTION	DATE	DWN	APVD
-	-	SEE SHEET 1	-	-	-

PACKING MATERIAL

ITEM	P/N	DESCRIPTION	Q'TY
1		CARTON L:500*W:330*H:240mm B三B	1PCS
2		PE BAG L:500*W:330*H:450*T0.025mm	1PCS
3		ZIP BAG L:290*W:110*T:0.04mm WITH BLACK MARK	1PCS
4		MINI TIE L=140mm COLOR:BLACK	1PCS
5		TRANSPARENCE ADHESIVE TAPE W:48mm	2960mm
6		刀卡 L490*W220mmC二C	1PCS
7		刀卡 L320*W220mmC二C	1PCS

DESCRIPTION

1. ACCORDING TO THE DRAWING FOLD THE CABLE.
2. BIG PE-BAG MUST PUT IN CARTON AND COVER ALL PRODUCTS
3. ENVELOPE THE CARTON ADD PACKAGE.
4. UNIT: mm

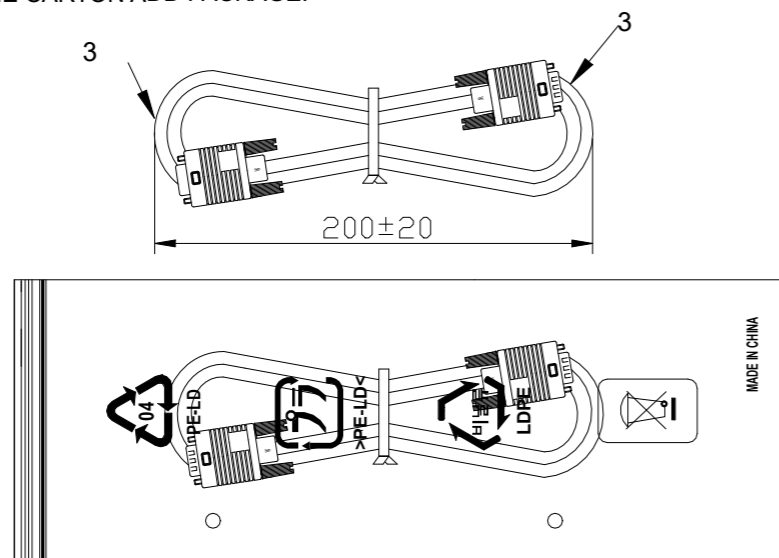

Q'TY : 92 PCS (A1)

N.W. : 13.80 KG/CTN (A1)

G.W. : 14.90 KG/CTN (A1)

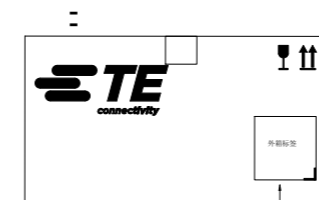

备注: 摆板时注意标签朝外摆放
 Note: When placing the board, make sure that the label is facing outward

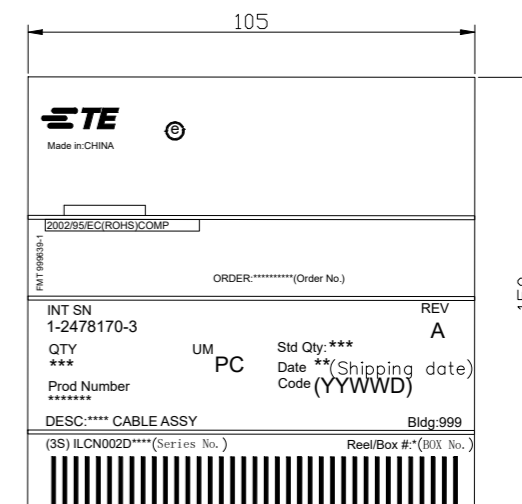

外箱标签

所有标签信息由业务提供

Carton label

All tag information is provided by the business

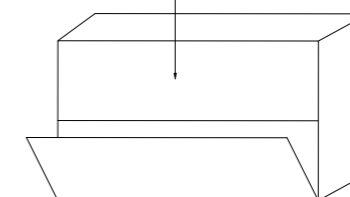
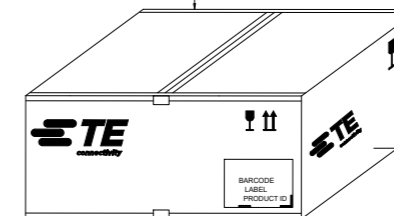
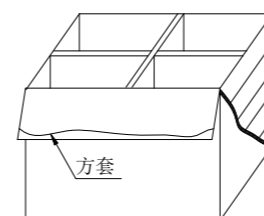

THIS DRAWING IS A CONTROLLED DOCUMENT.		DWN	GIRIDHAR, A	03MAY2024	STE TE Connectivity Ltd.
		CHK	WENKE HE	05MAY2024	
		APVD	WENKE HE	05MAY2024	
		PRODUCT SPEC	NAME		
		APPLICATION SPEC	DB 15P M TO M BLACK 5 FEET CABLE ASS'y		
		WEIGHT	0	A3	RESTRICTED TO
		CUSTOMER DRAWING	SCALE	1:1	
			SHEET	24 of 26	
			REV	A1	

PACKING INSTRUCTION

REVISIONS

P	LTR	DESCRIPTION	DATE	DWN	APVD
-	-	SEE SHEET 1	-	-	-

PACKING MATERIAL

ITEM	P/N	DESCRIPTION	Q'TY
1	56-A105105130	1050*1050*130 全板周转用胶合板(1050*1050*130 stranded board for turnover)	1PCS
2	56-B093050050	大包边930*50*50 厚5MM (LARGE EDGING 930*50*50 THICKNESS 5MM)	4PCS
3	56-B097050050	大包边970*50*50 (Large edging 970*50*50)	4PCS
4	56-E050000002	小包装膜 W=500MM(SMALL PACKAGING FILM W=500MM)	KG

包装规格
Packing specifications

纸箱尺寸: L500xW330xH240mm
6箱/层x4层=24箱/栈板

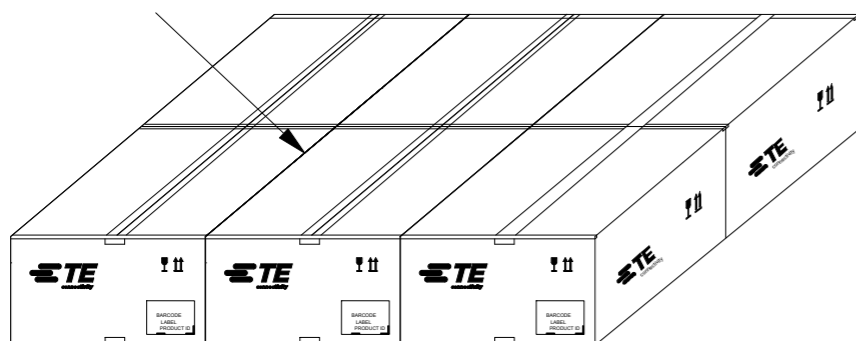

打板时统一标签朝外摆放

When playing the board, the uniform label is placed outward

Q'TY :

N.W. :

G.W. :

胶合栈板: (Glued pallet)
L1050*W1050*H130mm
材质: 胶合板
(Material: Plywood)

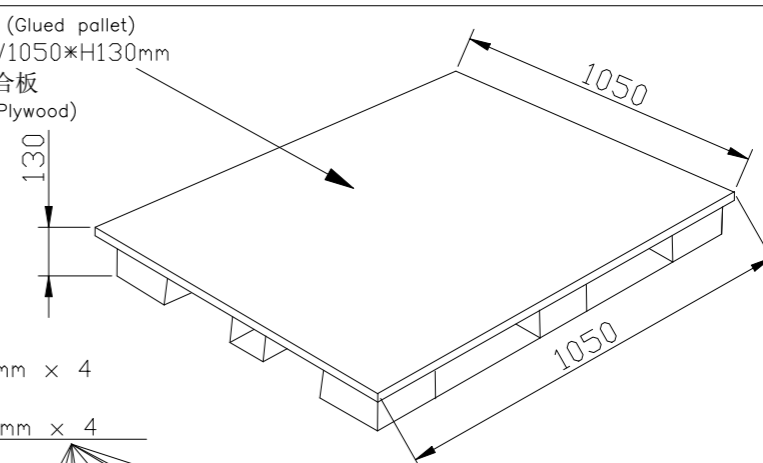

包边1尺寸:L930*W50*T5mm x 4 PCS
包边2尺寸:L970*W50*T5mm x 4 PCS

PE膜缠绕, 至少缠绕3层
全方位包裹产品

(PE film winding, at least 3 layers
Wrap your products in all directions)

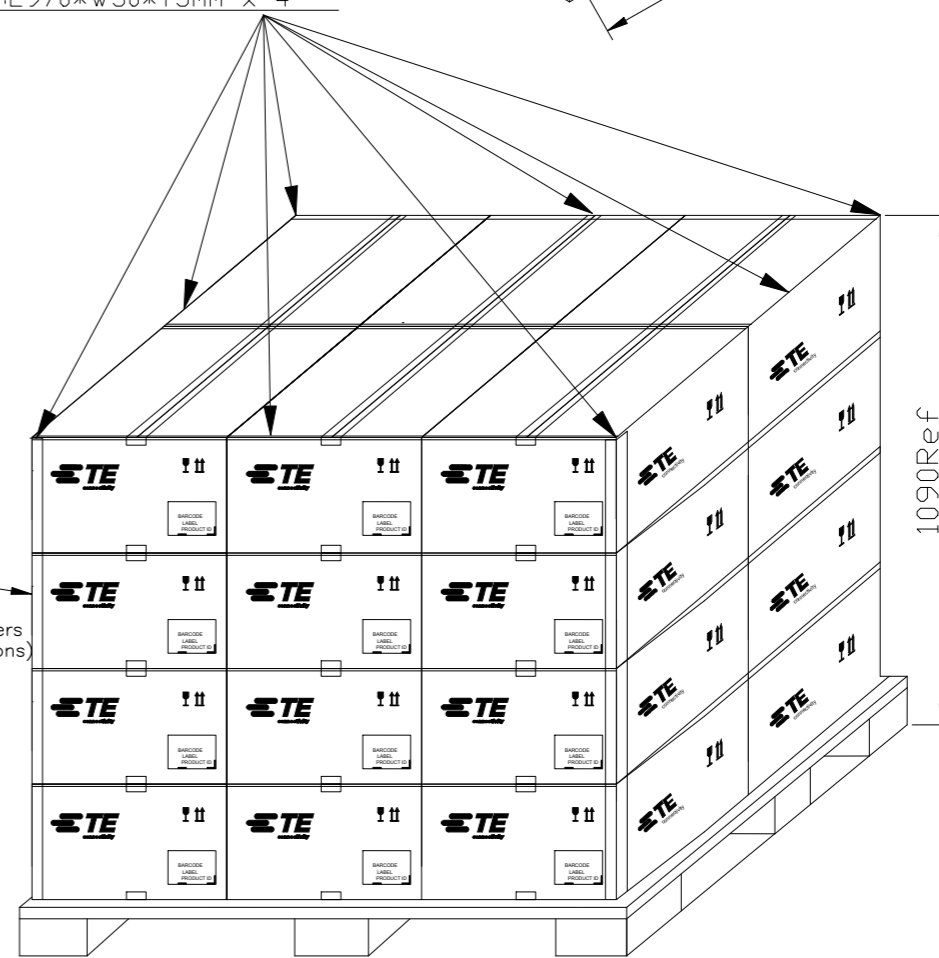

THIS DRAWING IS A CONTROLLED DOCUMENT.

DIMENSIONS:	TOLERANCES UNLESS OTHERWISE SPECIFIED:
mm	
	0 PLC ± -
	1 PLC ± -
	2 PLC ± -
	3 PLC ± -
	4 PLC ± -
	ANGLES ± -
MATERIAL	FINISH
-	-

DWN	GIRIDHAR, A	03MAY2024
CHK	WENKE HE	05MAY2024
APVD	WENKE HE	05MAY2024
PRODUCT SPEC	-	
APPLICATION SPEC	-	
WEIGHT	0	
CUSTOMER DRAWING		

STC TE Connectivity Ltd.

NAME: DB 9P M TO M BLACK 6 FEET CABLE ASS'y

SIZE	CAGE CODE	DRAWING NO	RESTRICTED TO
A3	00779	C-2478170	-
SCALE 1:1		SHEET 25 of 26	REV A1

P	LTR	DESCRIPTION	DATE	DWN	APVD
-	-	SEE SHEET 1	-	-	-

RoHS2.0

PACKING INSTRUCTION

TITLE: SIGNAL CABLE ASS'y

TE P/N: 2478170

List of playing board information

Custmor P/N	Length (feet)	Description	No. of boards	N. W	G. W
2478170-1	6	VGA 9P M-M 6FET 28AWG	2880	279.36	321.20
2478170-2	10	VGA 9P M-M 10FET 28AWG	1920	268.8	306.32
2478170-3	6	VGA 9P F-F 6FET 28AWG	2880	282.24	320
2478170-4	10	VGA 9P F-F 10FET 28AWG	1920	268.8	306.32
2478170-5	5	VGA 9P M-F 5FET 26AWG	2880	311.52	348.08
2478170-6	10	VGA 9P M-F 10FET 26AWG	1920	342.48	380.72
2478170-7	6	VGA 9P M-F 6FET 26AWG	2880	347.04	386
2478170-8	10	VGA 9P M-F 10FET 28AWG	1920	268.8	306.08
2478170-9	2.5	VGA 15P M-M 2.5FET 26AWG	3264	345.84	381.2
1-2478170-1	2.5	VGA 15P M-F 2.5FET 26AWG	3264	345.84	381.2
1-2478170-2	5	VGA 15P M-F 5FET 26AWG	2208	331.2	371.6
1-2478170-3	5	VGA 15P M-M 5FET 26AWG	2208	331.2	371.6

THIS DRAWING IS A CONTROLLED DOCUMENT.

DWN GIRIDHAR, A 03MAY2024

CHK WENKE HE 05MAY2024

APVD WENKE HE 05MAY2024

PRODUCT SPEC

APPLICATION SPEC

WEIGHT 0

CUSTOMER DRAWING



TE Connectivity Ltd.

NAME DB 9P M TO M BLACK 6 FEET CABLE ASS'y

SIZE CAGE CODE DRAWING NO RESTRICTED TO

A3 00779 C-2478170

SCALE 1:1 SHEET 26 OF 26 REV A1

DIMENSIONS:

mm

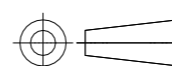

TOLERANCES UNLESS OTHERWISE SPECIFIED:

- 0 PLC ± -
- 1 PLC ± -
- 2 PLC ± -
- 3 PLC ± -
- 4 PLC ± -
- ANGLES ± -
- FINISH -

MATERIAL

-