

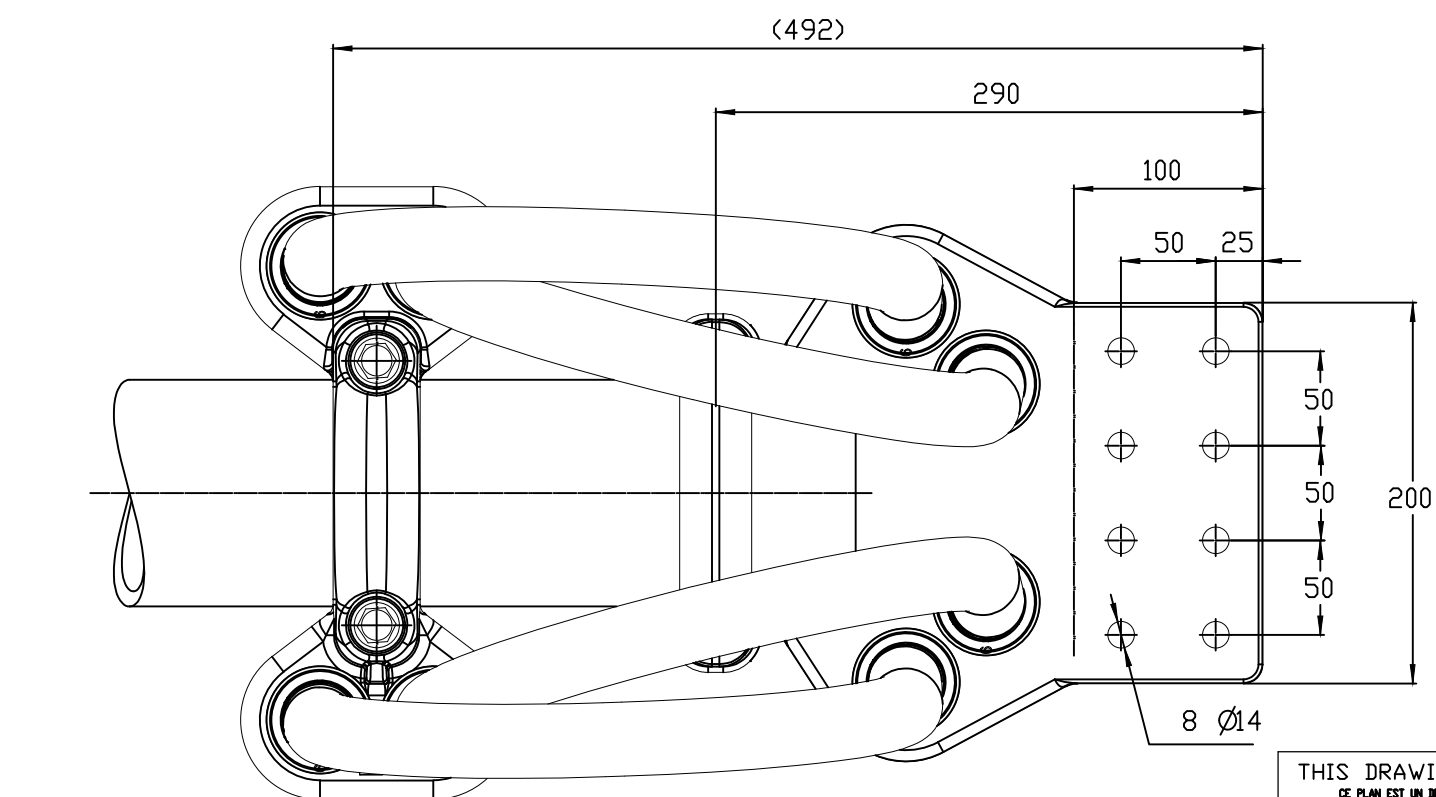

THIS DRAWING IS UNPUBLISHED.
 DIFFUSION RESTREINTE
 © COPYRIGHT 2011 by Tyco Electronics Corporation

RELEASED FOR PUBLICATION
 LIBRE A LA DIFFUSION
 2011
 ALL RIGHTS RESERVED.
 TOUS DROITS RESERVES

LOC		DIST		REVISIONS			
P	LTR REV	DESCRIPTION MODIFICATIONS	DATE	DWN DESS	APVD APPR		
-	-	A	CREATION	13-Mar-15	GL	-	
		B	UPDATED DRAWING	04-May-15	PG	-	

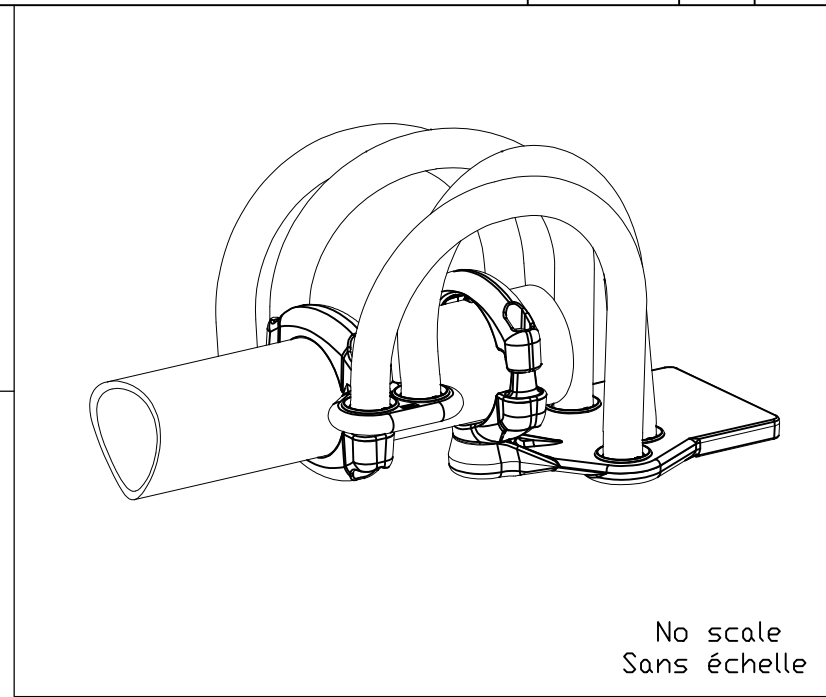
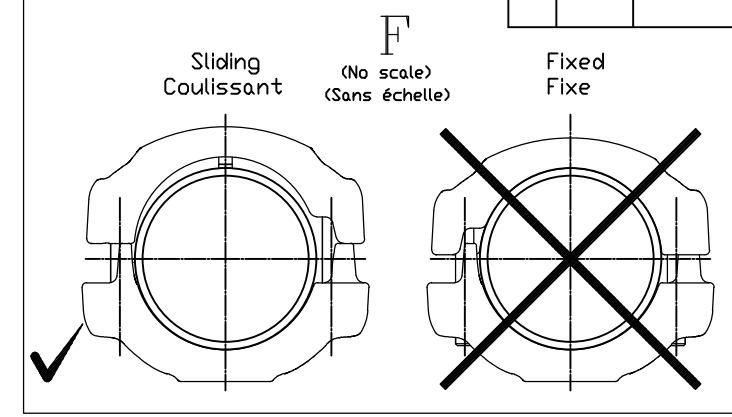
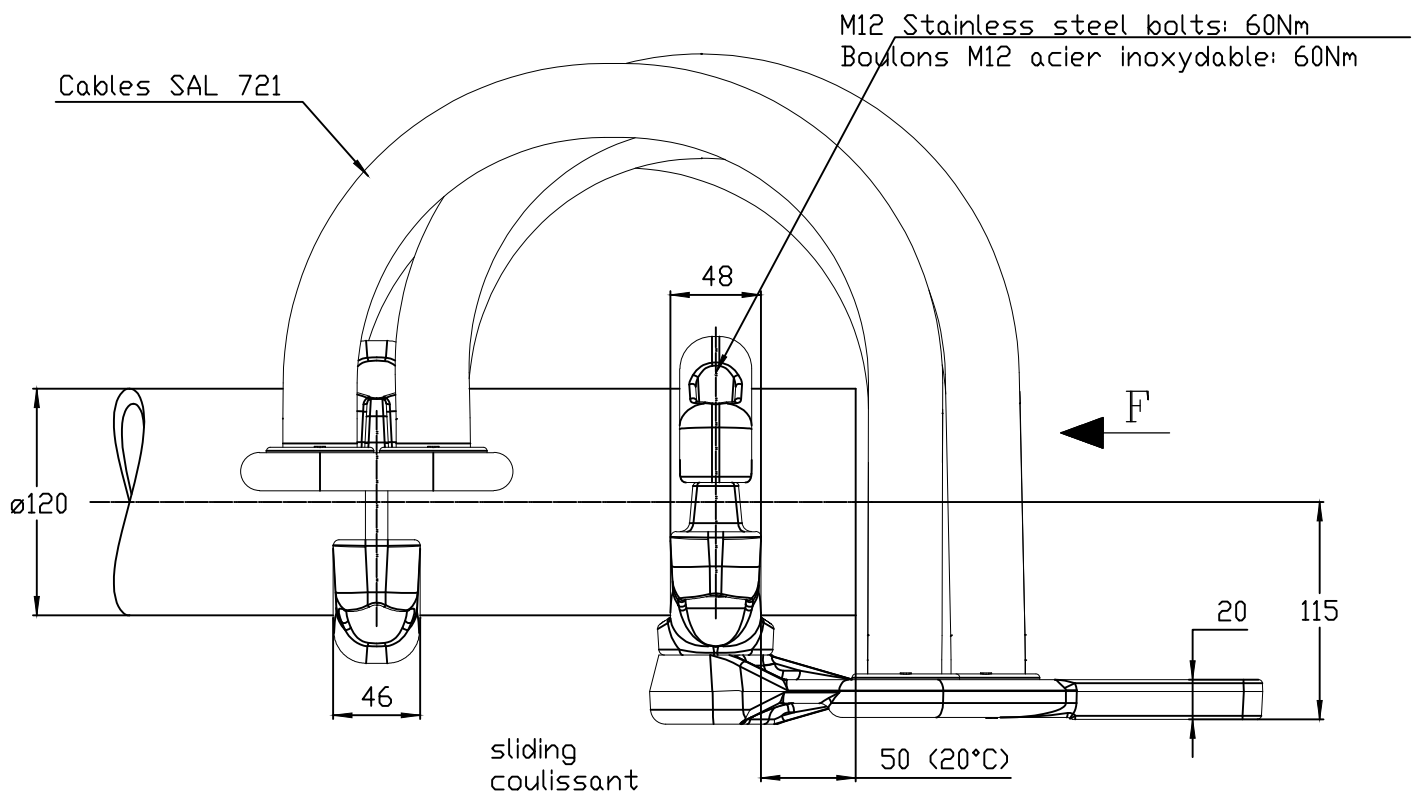

THIS DRAWING IS A CONTROLLED DOCUMENT. <small>CE PLAN EST UN DOCUMENT CONTROLÉ PAR TYCO ELECTRONICS CORPORATION IL EST SUSCEPTIBLE D'ÊTRE RÉVISÉ. POUR ÉDITION LA TROISIÈME RÉVISION, CONTACTER LE SERVICE TECHNIQUE DE TYCO ELECTRONICS SINEL SAS, 21220 GEVREY-CHAMBERTIN, FRANCE.</small>		DWN /DESSINE LAFORGE	13-Mar-15	 TE connectivity SIMEL PRODUCTS			
DIMENSIONS: mm		CHK/VERIFIE	-				
TOLERANCES UNLESS OTHERWISE SPECIFIED PER TOLERANCES NON SPECIFIEES SELON : -		APVD/APPROUVE	-	NAME TITRE EXPANSION CONNECTOR FOR TUBE ø120 TO PAD RACCORD A DILATATION SUR PLAGE POUR TUBE ø120 5 TTPDL 82 T120 100X200 R90 47			
		PRODUCT SPEC SPEC. PRODUIT 108-69090-001	-				
MATERIAL MATIERE	-	FINISH FINITION	-	SIZE FORMAT A3	CAGE CODE 00779	DRAWING NO No PLAN C-2839837	RESTRICTED TO RESERVE A -
ITEM:.....		APPROX. WEIGHT MASSE APPROX.	13,5kg	CUSTOMER DRAWING /PLAN CLIENT	UNIQUEMENT POUR REFERENCE	SCALE ECHELLE 1/4	SHEET FEUILLE 1 OF DE 1