

P	LTR	DESCRIPTION	DATE	DWN	APVD
A3		ADDED APPL SPEC (NOTE 2), 09-0014-04	20-1-2009	M.P	-
A4		ECR-09-006304	18-03-2009	M.G	-
A5		REDRAWN TO CREO	12APR2017	VH	JP

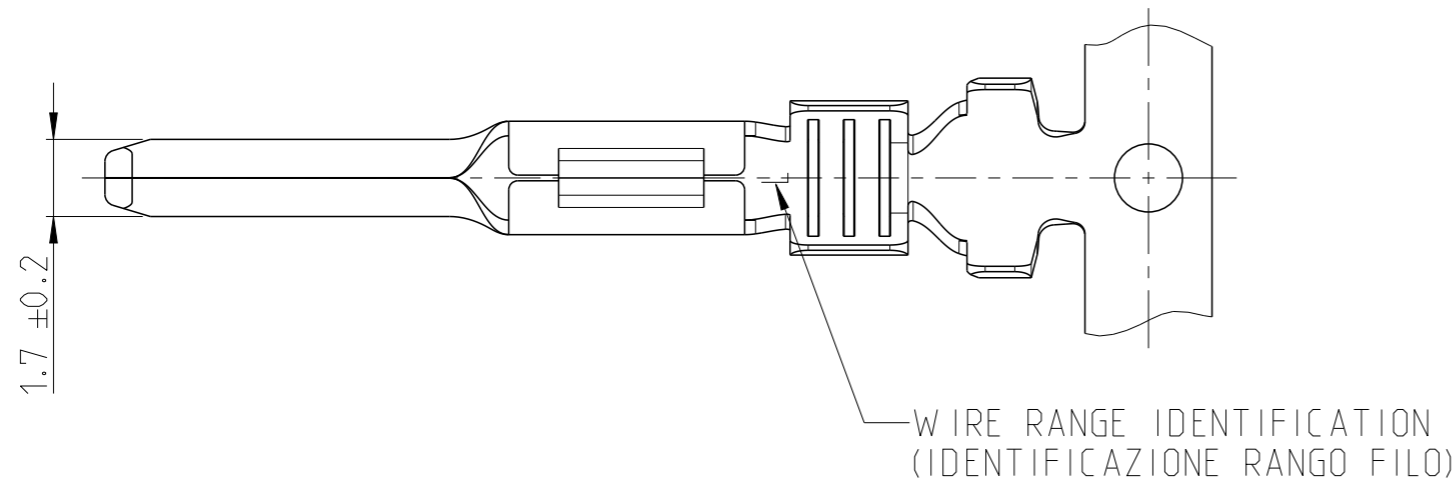
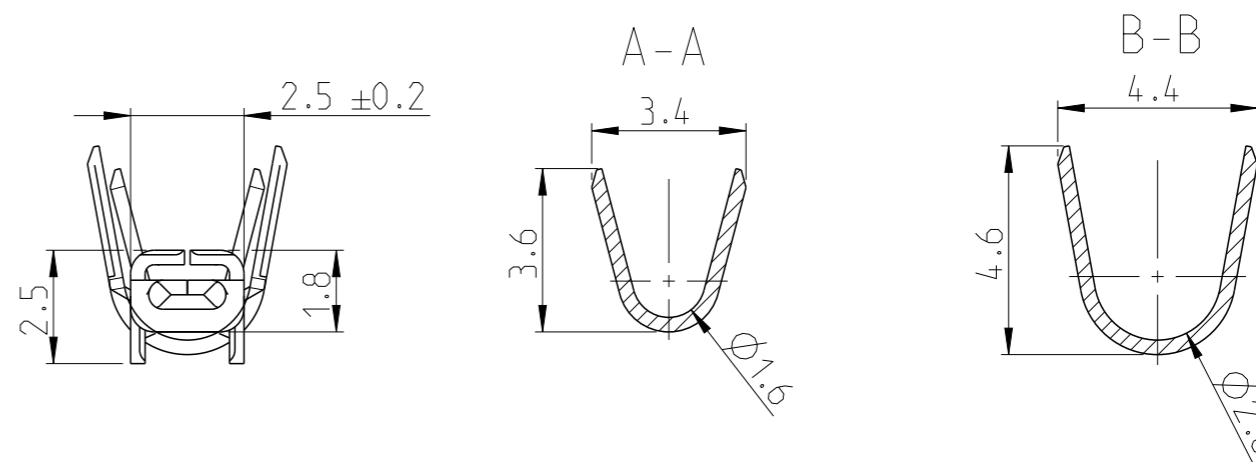
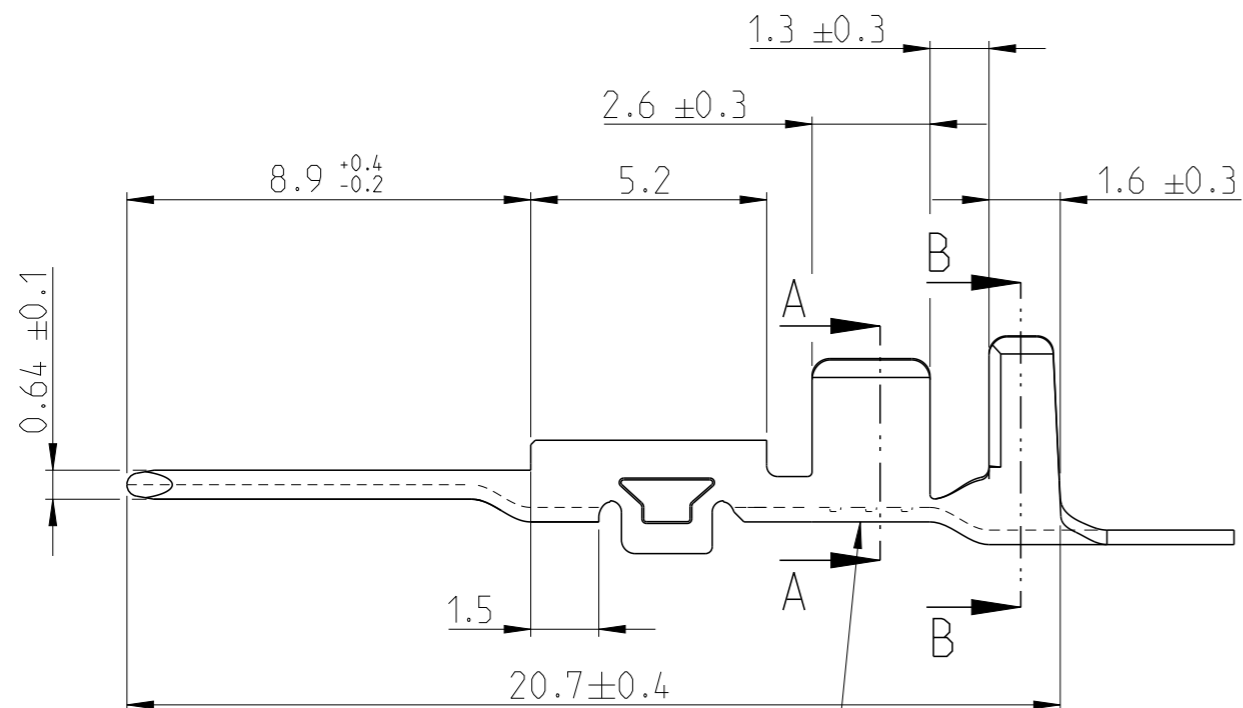

1. ITEM IS SUPPLIED REELED ON CARTON REEL WITH STRIP PITCH=11.9±0.2mm
 STATO DI FORNITURA: AVVOLTI SU BOBINA CON PASSO TRA TERMINALI DI 11.9±0.2

WIRE RANGE:	INSULATION RANGE:
Ø2.5 mm ²	Ø2.7-3.0 mm

CUSTOMER DRAWING FOR REFERENCE ONLY

THIS DRAWING IS A CONTROLLED DOCUMENT.

DWN P.SANTANGELO 28JAN98

CHK C.BERTINI 28JAN98

APVD -

PRODUCT SPEC 108-20175

APPLICATION SPEC 114-20095

WEIGHT -

DIMENSIONS:	TOLERANCES UNLESS OTHERWISE SPECIFIED:
mm	
	0 PLC ±
	1 PLC ±
	2 PLC ± ±0.3
	3 PLC ±
	4 PLC ±
	ANGLES ±2°
	FINISH -
	-

MATERIAL -

-

PRE-TIN	BRASS	A	284108-1
FINISH	MATERIAL	REV	PART NO.



MULTILOCK CONN. 070 SRS RAB CTC. SECOND GENERATION

SIZE A3 CAGE CODE - DRAWING NO C=284108 RESTRICTED TO -

CUSTOMER DRAWING SCALE 5:1 SHEET 1 OF 1 REV A5