

REVISIONS					
P	LTR	DESCRIPTION	DATE	DWN	APVD
	C	REVISED PER 0L20-0220-97	02OCT97	DKS	MJS
	C1	REVISED PER ECO-17-016781	10JAN2018	RS	DR

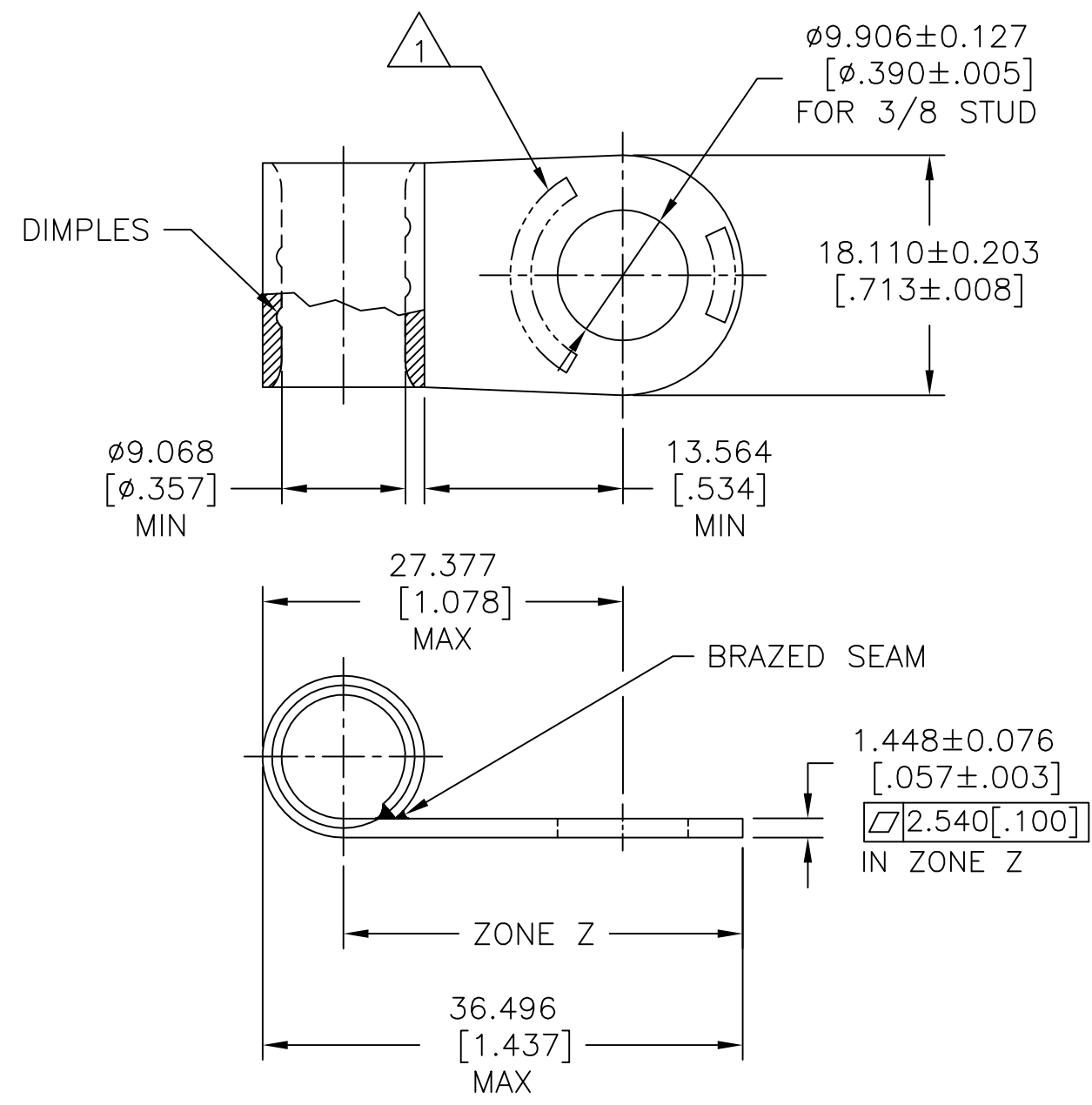

AMP WIRE RANGE	E13288 Listed
2 AWG SOLID OR STRANDED	2 AWG STRANDED
LR7189 Certified	MILITARY P/N AND CLASS
2 AWG SOLID OR STRANDED	NOT APPLICABLE

STAMP AMP 2W* 60-75 APPROX AS SHOWN.

50	LOOSE PIECE	321253
QTY	PACKAGE TYPE	AMP PART NUMBER

AMP INCORPORATED
 CUSTOMER SERVICE SYSTEMS

FOR ADDITIONAL PRODUCT INFORMATION OR COPIES OF DRAWINGS AND TECHNICAL DOCUMENTS	PRODUCT INFORMATION CENTER 1-800-522-6752	RECOMMENDED OPERATING TEMPERATURE: 170°[338°F] MAX
FOR APPLICATION TOOLING INFORMATION	TOOLING ASSISTANCE CENTER 1-800-722-1111	VOLTAGE RATING: NOT APPLICABLE
FOR ORDER ENTRY	1-800-526-5142	WIRE CROSS SECTIONAL AREA RANGE: 26.7-42.4mm ² [52,600-83,700] CIR MILS SOLID OR STRANDED

THIS DRAWING IS A CONTROLLED DOCUMENT.	
DIMENSIONS: mm [INCHES]	TOLERANCES UNLESS OTHERWISE SPECIFIED:
	0 PLC ± - 1 PLC ± - 2 PLC ± - 3 PLC ± 0.127[.005] 4 PLC ± - ANGLES ± -
MATERIAL COPPER PER ASTM B-152 ANNEALED	FINISH TIN PLATE 0.00254[.000100] MIN THK PER ASTM B-545

DWN DK SCHRUM 02OCT97	NAME TERMINAL, RING TONGUE, FLAG, SOLISTRAND™, 2 AWG	RESTRICTED TO
CHK MJ SPICER 03OCT97		
APVD JL MECKLEY 03OCT97		
PRODUCT SPEC UL 486 A-B		
APPLICATION SPEC	SIZE A3	CAGE CODE 00779
WEIGHT -	DRAWING NO C-321253	RESTRICTED TO -
CUSTOMER DRAWING		SCALE 2:1
		SHEET 1 OF 1
		REV C1

