

REVISIONS					
P	LTR	DESCRIPTION	DATE	DWN	APVD
	A	ECN-22-144091	18MAR2022	NPR	CDS

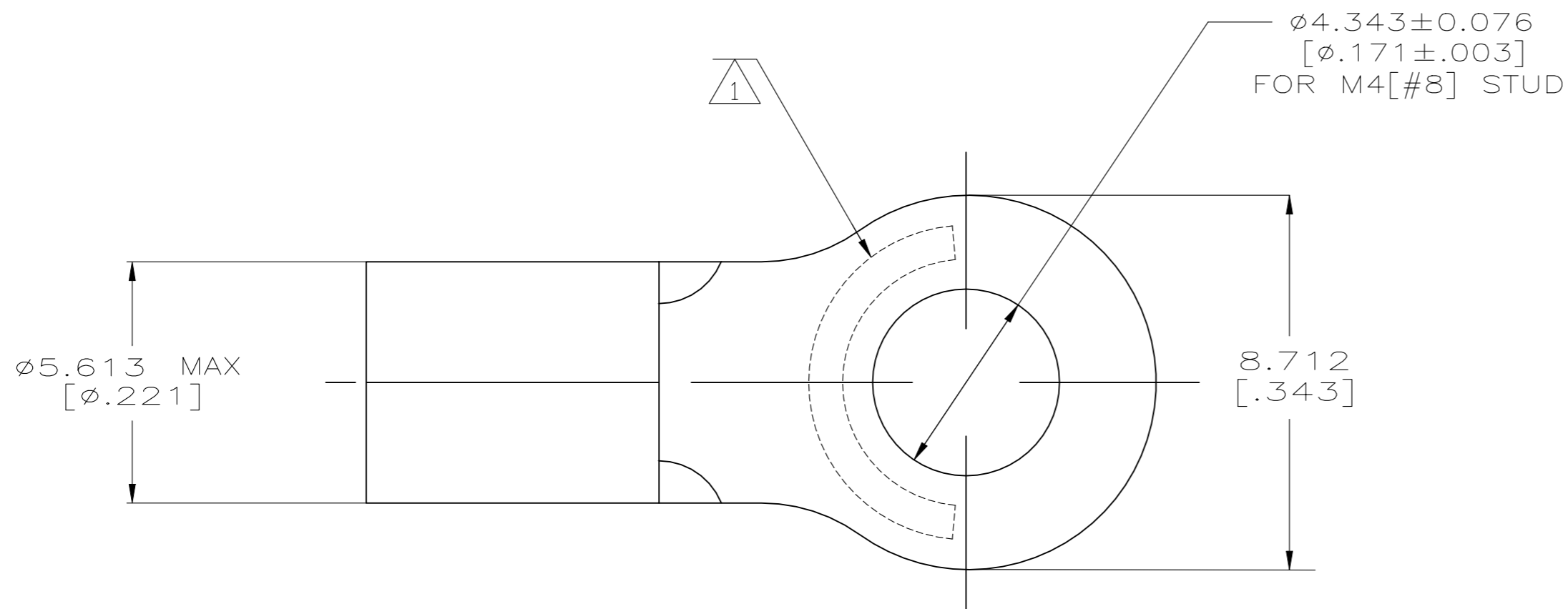

- 1 STAMP AMP 12-10* APPROX AS SHOWN
- 2 FINISH: TIN PLATE 0.00254[.000100] MIN EXT THK PER ASTM B545
- 3 NOTE DELETED
- 4 MATERIAL: COPPER PER ASTM B152, ANNEALED
- 5 MATERIAL THK: 0.991±0.051[.039±.002]

AMP WIRE RANGE	Listed FILE E13288
12-10 AWG STRANDED	12-10 AWG STRANDED

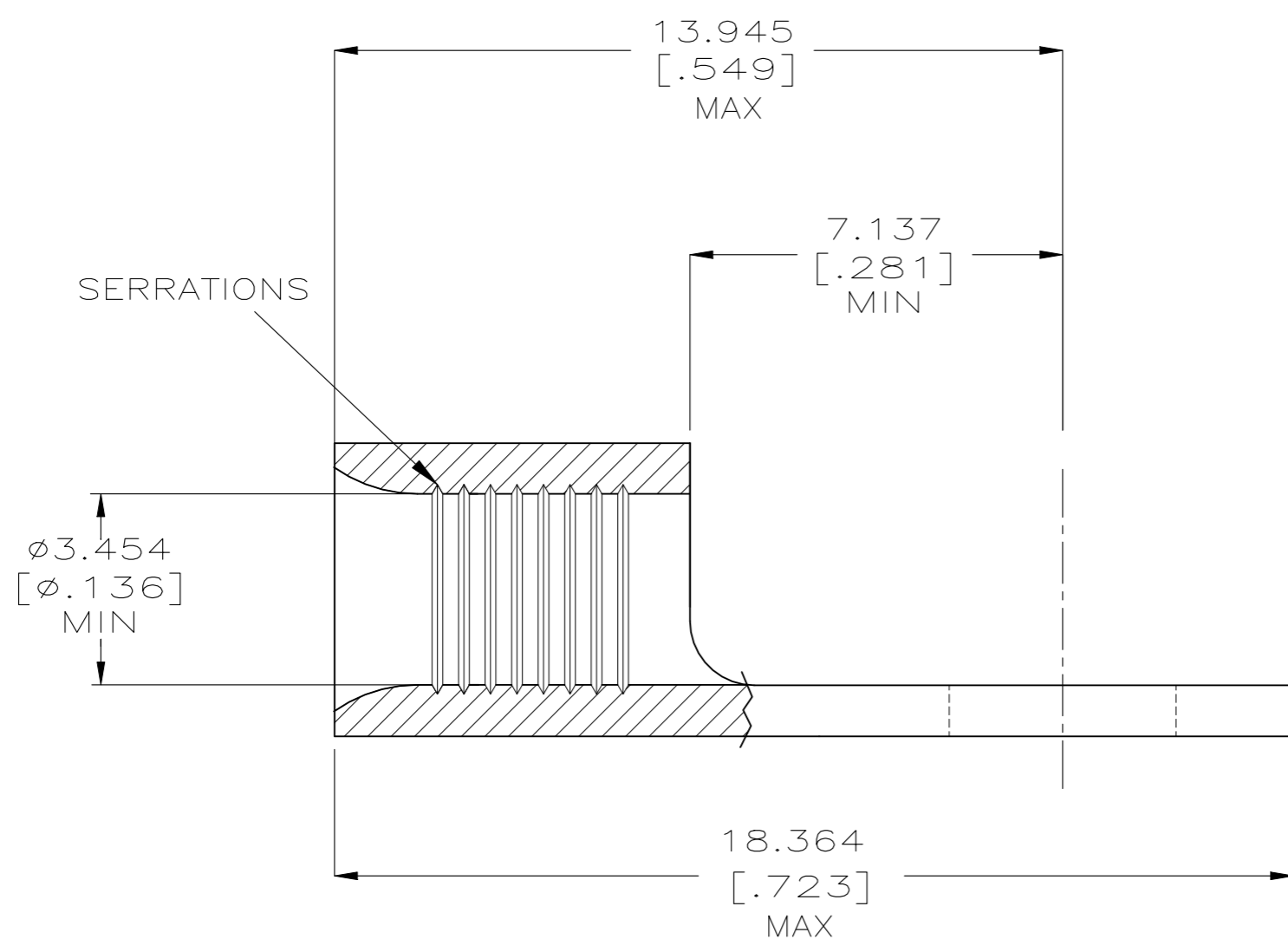

500	LOOSE PIECE	32519
QTY	PACKAGE TYPE	PART NO.

AMP INCORPORATED CUSTOMER SERVICE SYSTEMS		MAX RECOMMENDED OPERATING TEMPERATURE: 170°C [338°F]	THIS DRAWING IS A CONTROLLED DOCUMENT.		DWN DK SCHRUM 4/14/92	TE Connectivity
FOR ADDITIONAL PRODUCT INFORMATION OR COPIES OF DRAWINGS AND TECHNICAL DOCUMENTS	PRODUCT INFORMATION CENTER 1-800-522-6752	VOLTAGE RATING: N/A	DIMENSIONS: MM [INCHES]	TOLERANCES UNLESS OTHERWISE SPECIFIED:	CHK DA PATTERSON 4/14/92	
FOR APPLICATION TOOLING INFORMATION	TOOLING ASSISTANCE CENTER 1-800-722-1111	CIRCULAR MIL AREA: 2.62-6.64mm ² [5,180-13,100] STRANDED		0 PLC ± - 1 PLC ± - 2 PLC ± - 3 PLC ± 0.127[.005] 4 PLC ± - ANGLES ± -	APVD JL MECKLEY 4/14/92	NAME UL 486A-B
FOR ORDER ENTRY	1-800-526-5142	THIS DRAWING IS A CONTROLLED DOCUMENT FOR AMP INCORPORATED. IT IS SUBJECT TO CHANGE AND THE CONTROLLING ENGINEERING ORGANIZATION SHOULD BE CONTACTED FOR THE LATEST REVISION.	MATERIAL	FINISH	PRODUCT SPEC APPLICATION SPEC	SIZE A2
			4	2	WEIGHT -	CAGE CODE 00779
					DRAWING NO 32519	RESTRICTED TO -
					SCALE 4:1	SHEET 1 OF 1
					CUSTOMER DRAWING	REV A