

THIS DRAWING IS UNPUBLISHED. RELEASED FOR PUBLICATION
 © COPYRIGHT - By - ALL RIGHTS RESERVED.

REVISIONS				
P	LTR	DESCRIPTION	DATE	APVD
D2		REVISED PER ECO-16-004986	20JUN2016	NK DR

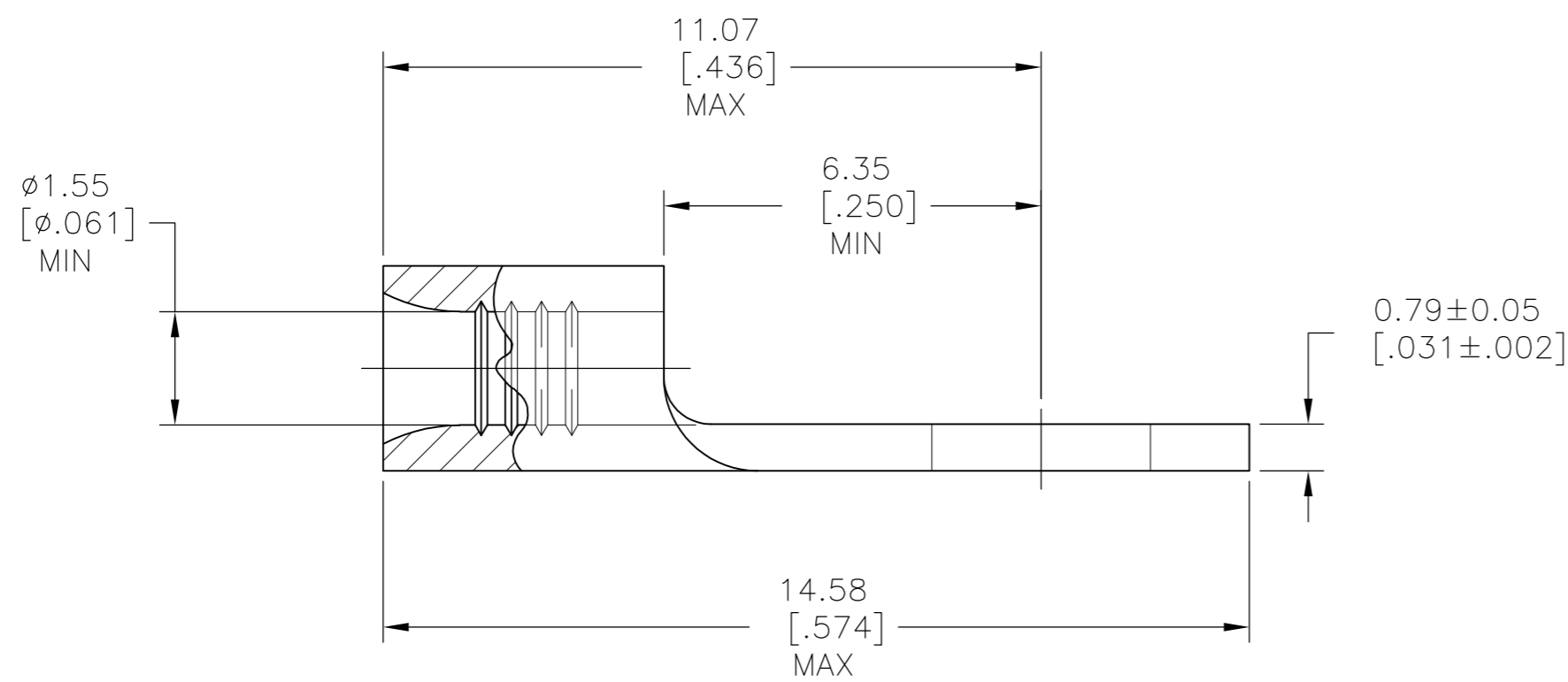
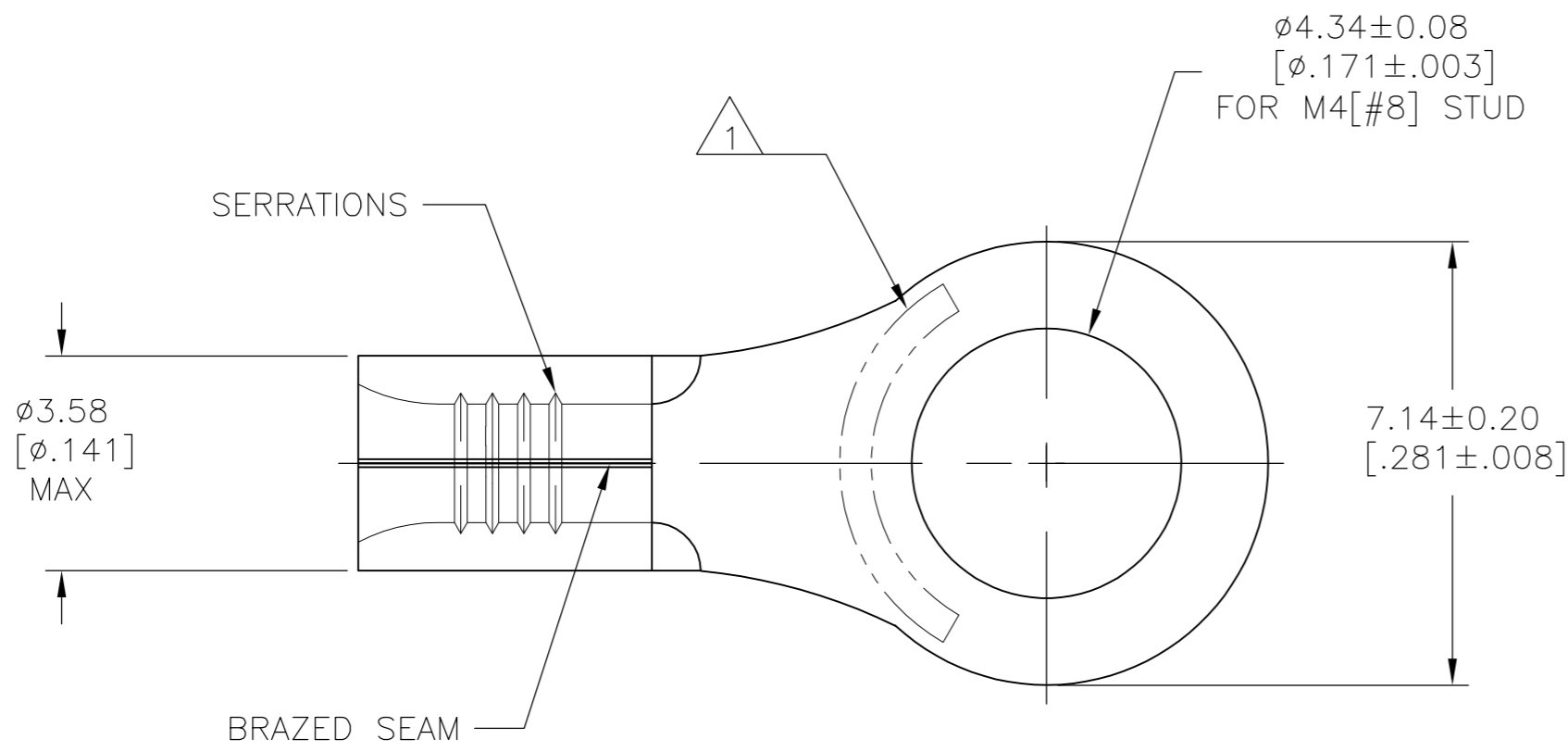

AMP WIRE RANGE	E13288 Listed
22-16 AWG SOLID OR STRANDED	22-16 AWG SOLID OR STRANDED
LR7189 Certified	MILITARY P/N AND CLASS
22-16 AWG SOLID OR STRANDED	NOT APPLICABLE

- STAMP AMP 22-18* APPROX AS SHOWN
22-16 TERMINALS ARE STAMPED 22-18 IN
ACCORDANCE WITH MILITARY SPEC SAER AS7928
COMMERCIAL WIRE RANGE IS 22-16.
- TIN PL 0.00254[.000100] MIN THK
PER ASTM B545.
- GOLD PL 0.00127[.000050] MIN THK
PER MIL-G-45204 OVER NICKEL PL
0.00076[.000030] MIN THK PER SAE AMS QQ-N-290.
- TIN LEAD PLATE 0.01016-0.02032
[.000400-.000080] THK PER MIL-P-81728.
- PRE-PRODUCTION - FASR REQ.

FINISH	QUANTITY	PACKAGING TYPE	PART NO
	1000	LOOSE PIECE	34108-2
	100	LOOSE PIECE, BOX	8-34108-1
	5000	ON TAPE	2-34108-2
	1000	LOOSE PIECE	1-34108-1
	1000	LOOSE PIECE	34108

AMP INCORPORATED
CUSTOMER SERVICE SYSTEMS

FOR ADDITIONAL PRODUCT INFORMATION OR COPIES OF DRAWINGS AND TECHNICAL DOCUMENTS	PRODUCT INFORMATION CENTER 1-800-522-6752	MAX RECOMMENDED OPERATING TEMPERATURE: 170°C[338°F] MAX
FOR APPLICATION TOOLING INFORMATION	TOOLING ASSISTANCE CENTER 1-800-722-1111	VOLTAGE RATING: NOT APPLICABLE
FOR ORDER ENTRY	1-800-526-5142	WIRE CROSS SECTIONAL AREA RANGE: 0.26-1.65mm ² [509-3,260] CIR MILS SOLID OR STRANDED

THIS DRAWING IS A CONTROLLED DOCUMENT.		DWN TA BRINKMAN 3-10-93	TE Connectivity	
DIMENSIONS: mm [INCHES]		CHK DA PATTERSON 3-10-93	NAME DE MILLER	
TOLERANCES UNLESS OTHERWISE SPECIFIED:		APVD DE MILLER 3-10-93	PRODUCT SPEC	
0 PLC ± -		APPLICATION SPEC		
1 PLC ± -		WEIGHT -		
2 PLC ± -		SIZE A2 CAGE CODE 00779 DRAWING NO C=34108		
3 PLC ± -		RESTRICTED TO -		
4 PLC ± -		SCALE 10:1 SHEET 1 OF 1 REV D2		
ANGLES ± -		CUSTOMER DRAWING		
FINISH SEE TABLE				