

REVISIONS					
REV	DATE	DESCRIPTION	BY	CHK	APP'D
T3	28JUL2022	REVISED PER ECR-21-118795	SK	VS	

- 1 PARTS COMPLY TO AMP SOLDERABILITY SPECIFICATION 109-11-3.
- 2 CONTACT IS PLATED OVERALL WITH 0.00127 [.000050] NICKEL, THEN 0.00076 [.000030] GOLD OVER CONTACT LENGTH INDICATED AND MATTE TIN LEAD ON SOLDER TAIL END.
- 3 CIRCUIT IDENTIFICATION CHARACTERS ARE ADJACENT TO THE INDICATED CAVITIES, BUT LOCATION AND ORIENTATION MAY DIFFER FROM PRINT.
- 4 DIMENSIONS IN BRACKETS ARE IN INCHES.
- 5 CONTACT IS PLATED OVERALL WITH 0.00127 [.000050] NICKEL, THEN 0.00076 [.000030] GOLD OVER CONTACT LENGTH INDICATED AND MATTE TIN ON SOLDER TAIL END.
- 6 SUPERSEDED BY 350760-5
- 7 DIMENSIONS WITH REPRESENT PRODUCT IN DRY CONDITION. ADDITIONAL 2% GROWTH DUE TO END USE LOCATION MOISTURE ABSORPTION MAY OCCUR AND SHOULD BE ACCOUNTED FOR.

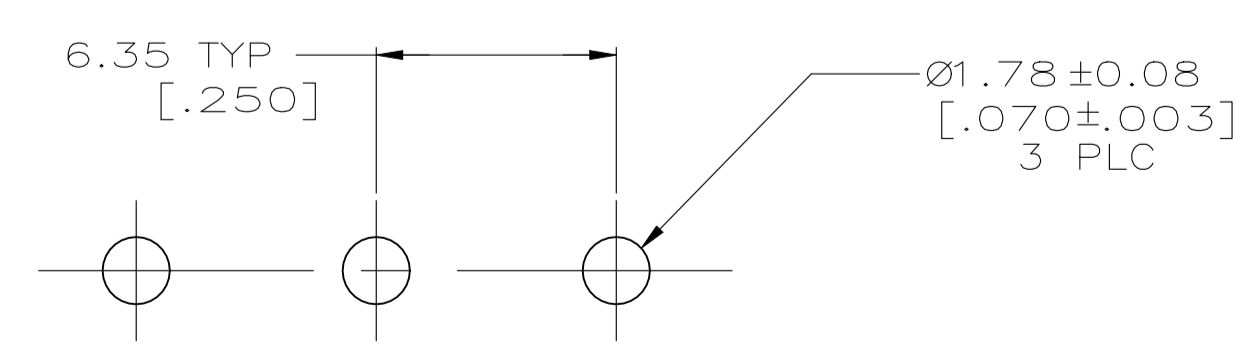

RECOMMENDED MOUNTING HOLE PATTERN FOR 1.57 [.062] THICK P.C. BOARD

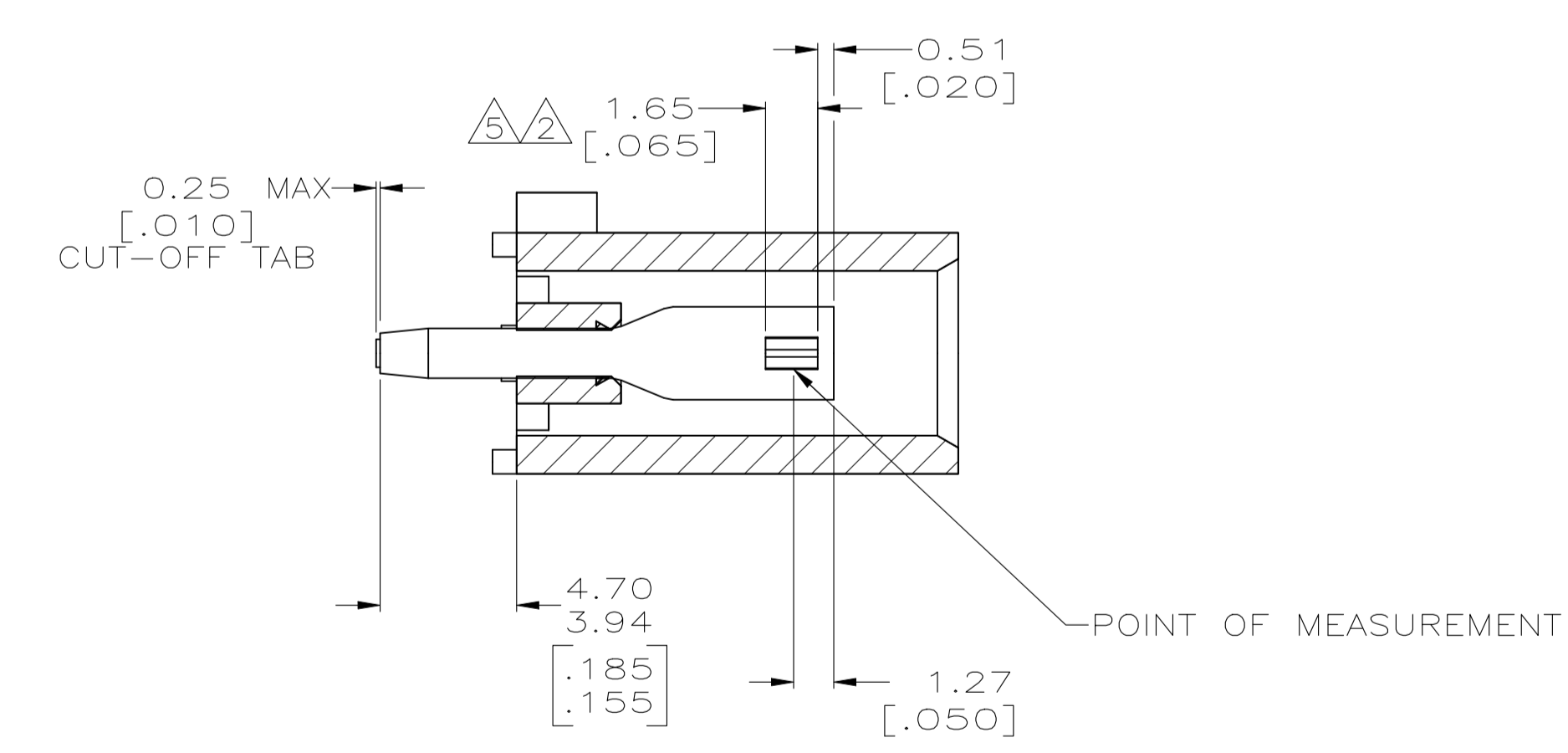
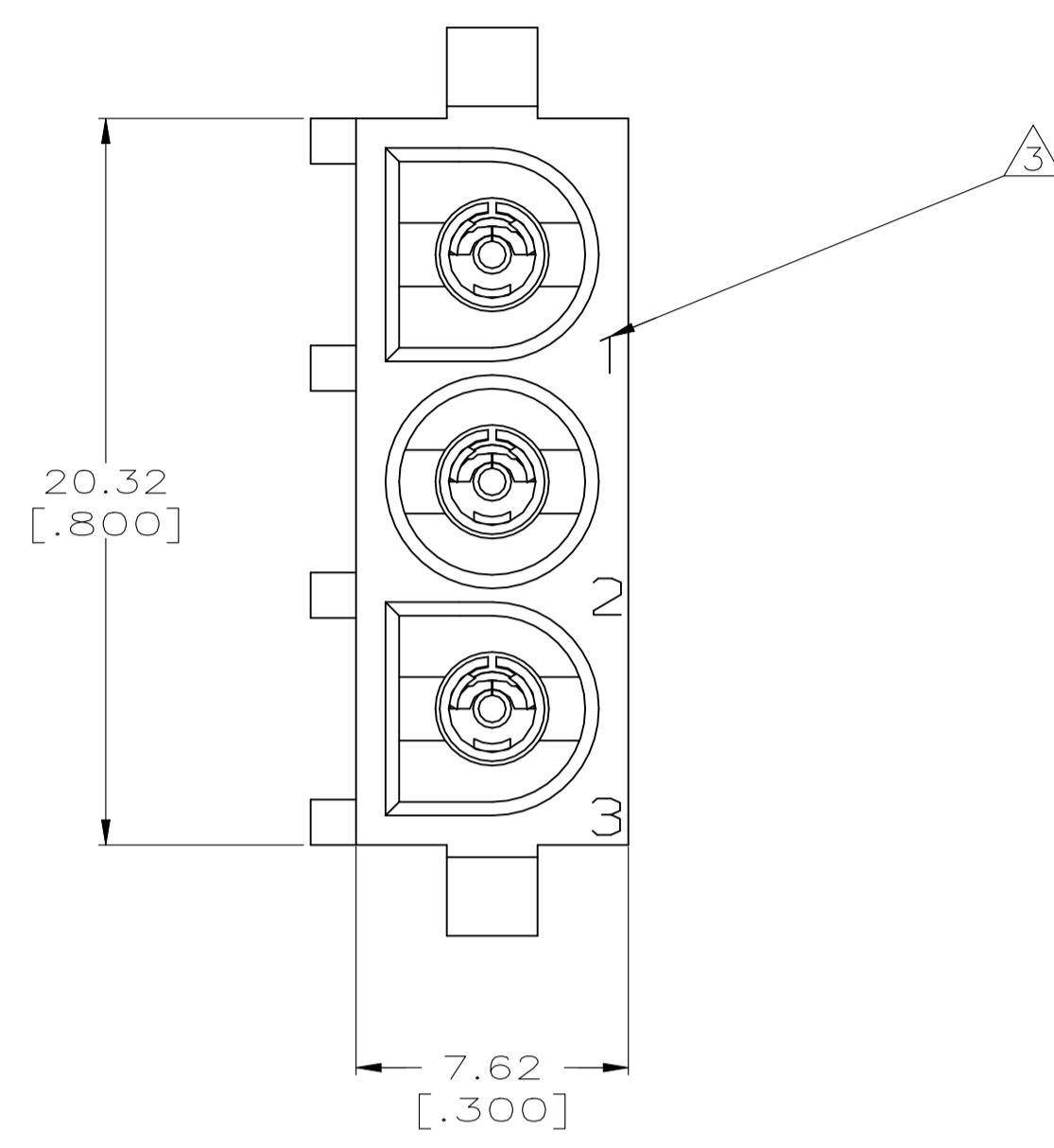
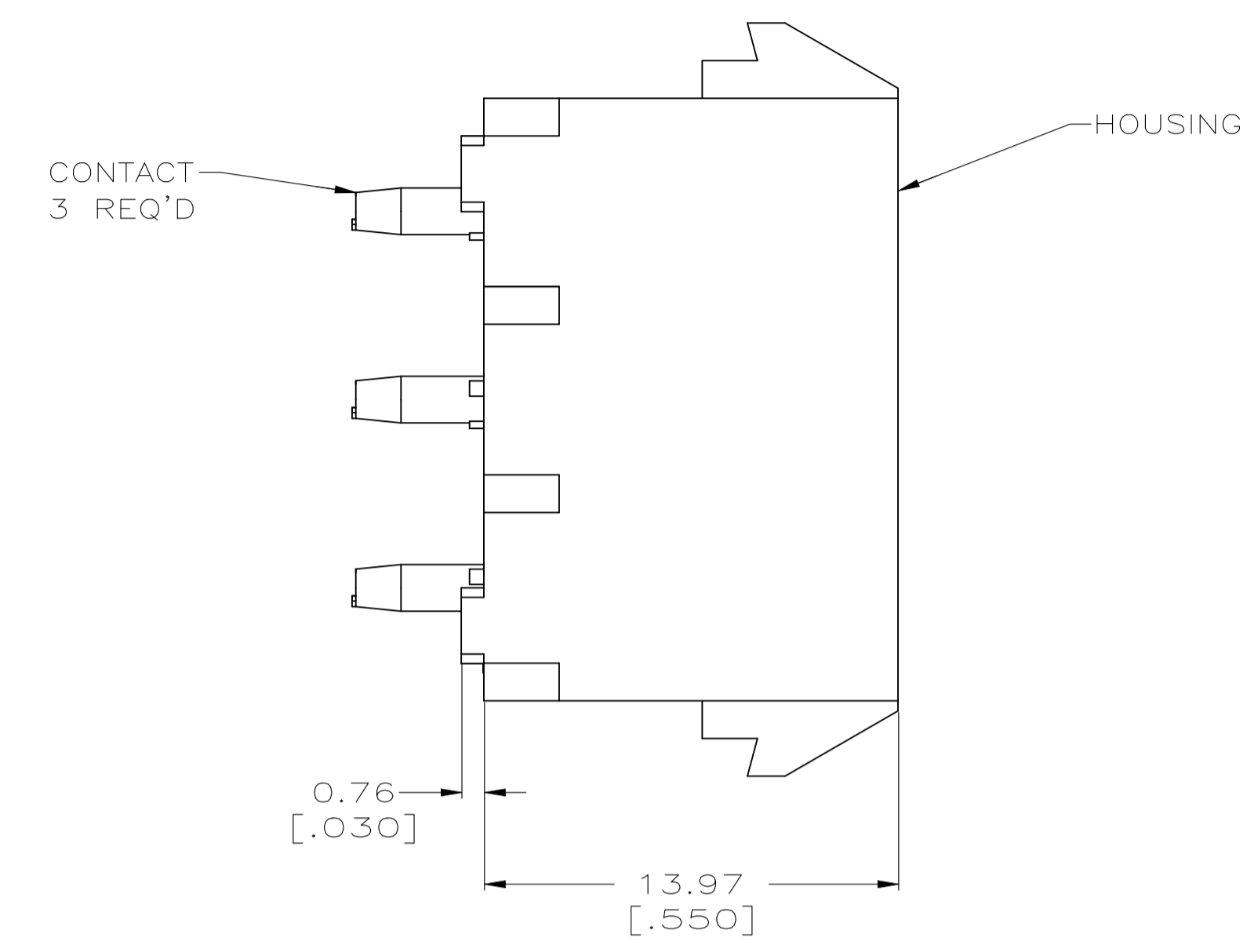
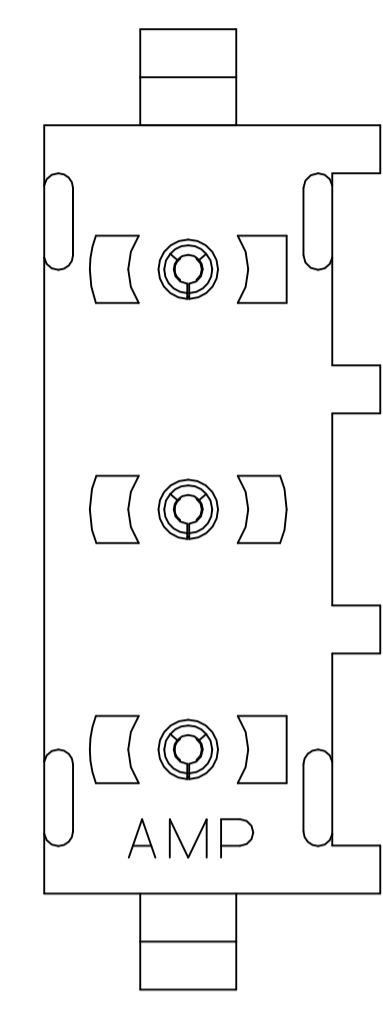
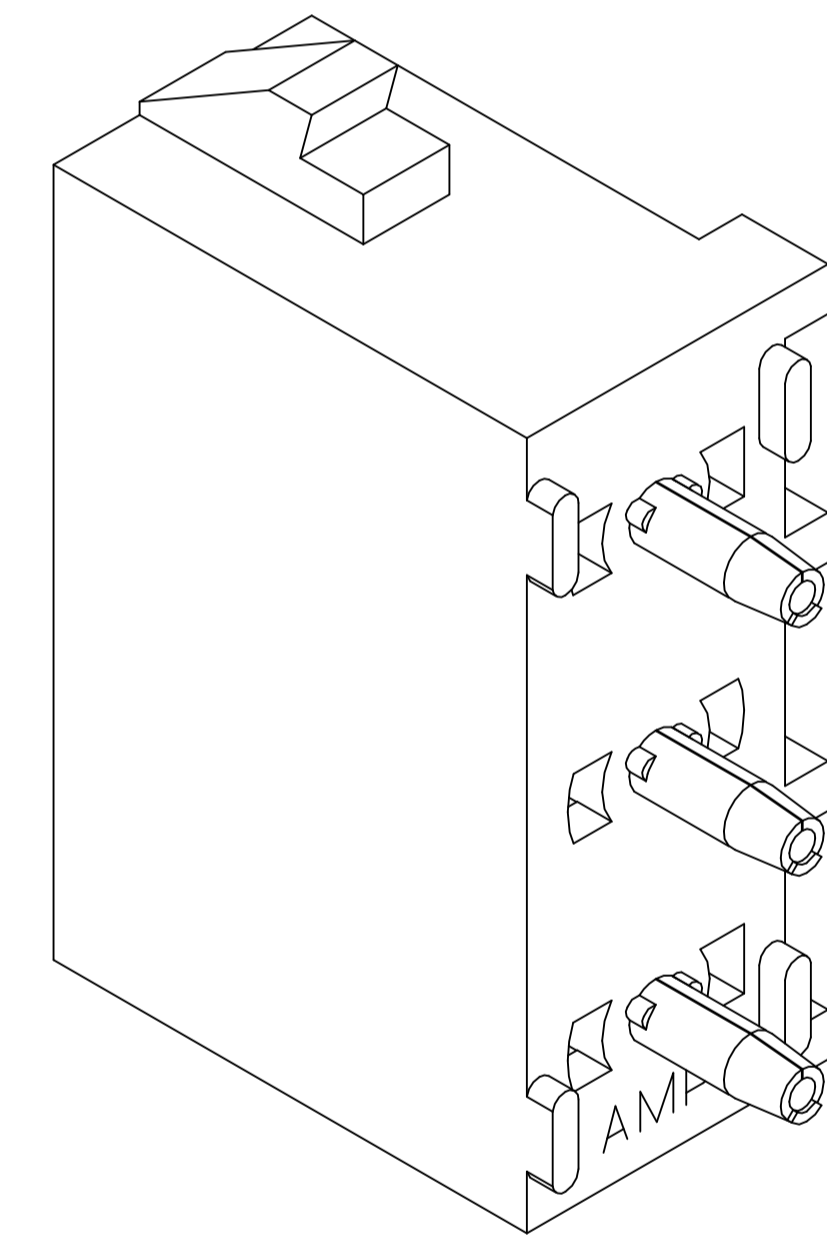

3-DIMENSIONAL MODEL NTS

PHOSPHOR BRONZE, GOLD	NYLON,UL94V-2,NATURAL	350760-5
PHOSPHOR BRONZE, PRE-TIN	NYLON,UL94V-2,NATURAL	350760-4
PHOSPHOR BRONZE, GOLD	NYLON,UL94V-2,NATURAL	350760-3
CONTACT MATERIAL AND FINISH	HOUSING MATERIAL	PART NUMBER

THIS DRAWING IS A CONTROLLED DOCUMENT.		DIN R LEWIS 8-19-98	
DIMENSIONS: mm [INCHES]		CHK R SWING 8-19-98	
TOLERANCES UNLESS OTHERWISE SPECIFIED:		APP'D M TRULL 8-19-98	NAME
0 PLC ± -	1 PLC ± -	2 PLC ± 0.13 [.005]	PRODUCT SPEC
3 PLC ± -	4 PLC ± -	ANGLES ± 0°30'	APPLICATION SPEC
MATERIAL SEE TABLE	FINISH SEE TABLE	WEIGHT 0.000000	SIZE CAGE CODE DRAWING NO
		A1 00779	RESTRICTED TO
		SCALE 5:1	SHEET 1 OF 1
		REV T3	