

THIS DRAWING IS UNPUBLISHED. RELEASED FOR PUBLICATION

© COPYRIGHT - By - ALL RIGHTS RESERVED.

LOC	DIST	REVISIONS					
AF	50	P	LTR	DESCRIPTION	DATE	DWN	APVD
		S		REVISED PER ECR-13-004343	30JUL13	KH	KR

- 1 MATES WITH .032±.001x.250 TAB
- 2 WIRE STRIP LENGTH .281
- 3 INSULATION SIZE .160 MAX DIA
- △5 DIMENSION DOES NOT INCLUDE TRIM BURR
- △6 .015 MAX CARRIER TRIM BURR PER SIDE IS ALLOWABLE IN THE SHADED AREA

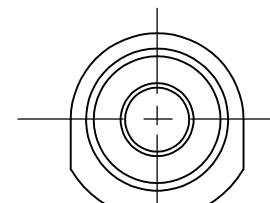
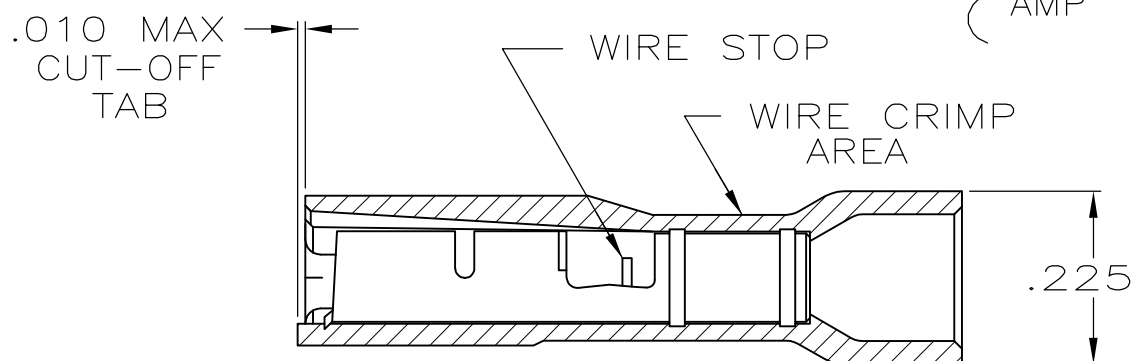
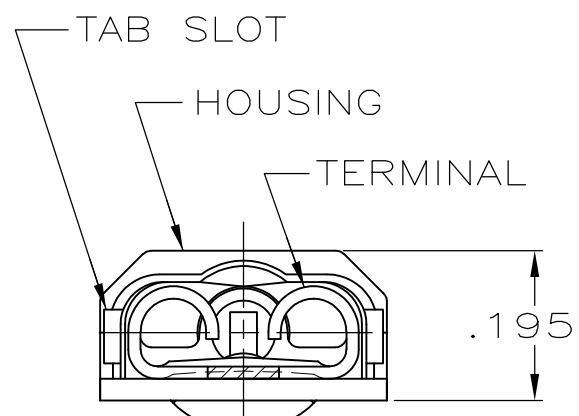
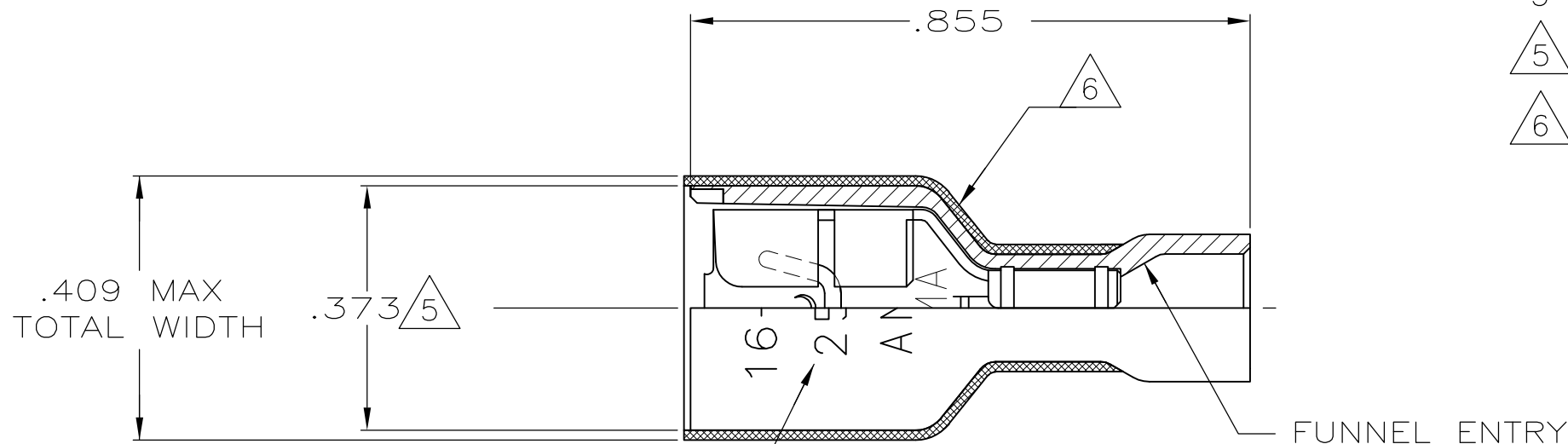

HOUSING: NYLON, COLOR-BLUE TRANSLUCENT	3-350820-2
RECEPTACLE: BRASS TIN	
MATERIAL & FINISH	PART NO

THIS DRAWING IS A CONTROLLED DOCUMENT.		DWN P FORTNEY 10/5/88	 TE Connectivity		
DIMENSIONS: INCHES		CHK JR RUTH 10/6/88			
TOLERANCES UNLESS OTHERWISE SPECIFIED:		APVD KA RANDOLPH 10/6/88	NAME RECEPTACLE ASSY, ULTRA-FAST, LOOSE PIECE, .250 SERIES, 16-14 AWG		
0 PLC ± -		PRODUCT SPEC 108-2043	SIZE A3		
1 PLC ± -		APPLICATION SPEC 114-2123	CAGE CODE 00779	DRAWING NO C-350820	RESTRICTED TO -
2 PLC ± -		WEIGHT -	SCALE 4:1		
3 PLC ± .015		CUSTOMER DRAWING			
4 PLC ± -		SHEET 1 OF 1			
ANGLES ± -		REV S			
FINISH SEE TABLE					