

P	LTR	DESCRIPTION	DATE	DWN	APVD
P9		REDRAWN PER ECO-19-005708	07MAY2019	BKW	SF

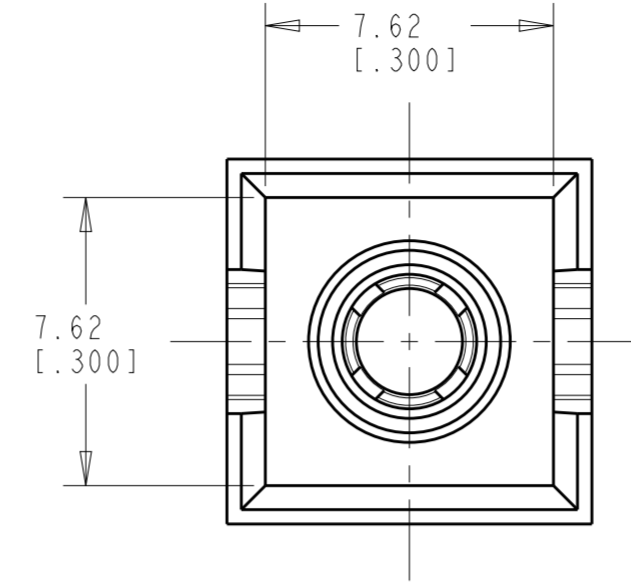

1. MATES HOUSING 350865.
2. DIMENSIONS IN BRACKETS ARE IN INCHES.
3. DIMENSIONS SHOWN REPRESENT PRODUCT IN DRY, AS MOLDED, CONDITION. ADDITIONAL 2% GROWTH DUE TO SUBSEQUENT MOISTURE ABSORPTION MAY OCCUR AND SHOULD BE ACCOUNTED FOR.
4. FOUR RIBS EQUALLY SPACED, NO SPECIFIC ORIENTATION. NO RIBS OR SIX RIBS EQUALLY SPACED, NO SPECIFIC ORIENTATION, OPTIONAL.
5. CSA LOGO LOCATED APPROXIMATELY AS SHOWN.
6. MATERIAL: PA66, UL94 V-0, GWIT 775°C
7. TRADEMARK LOCATION: AMP OR TE

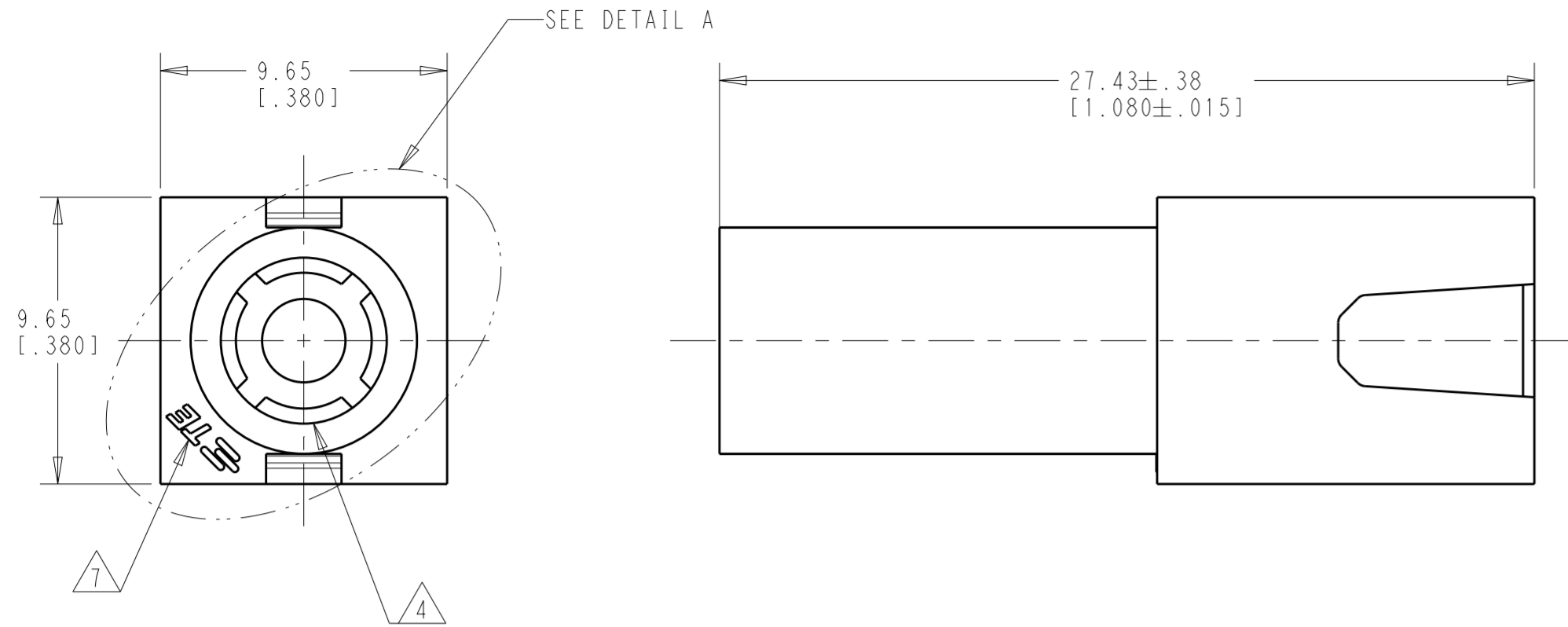
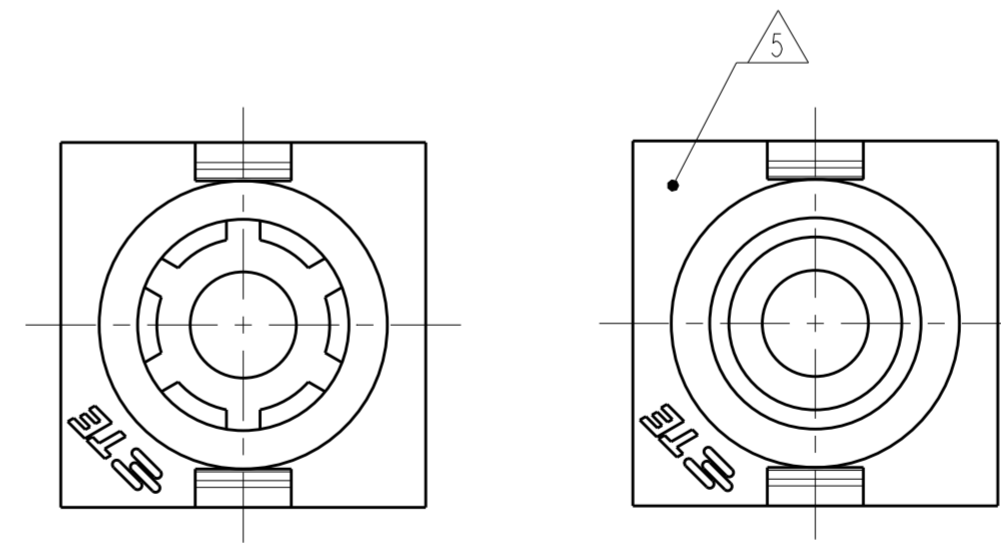
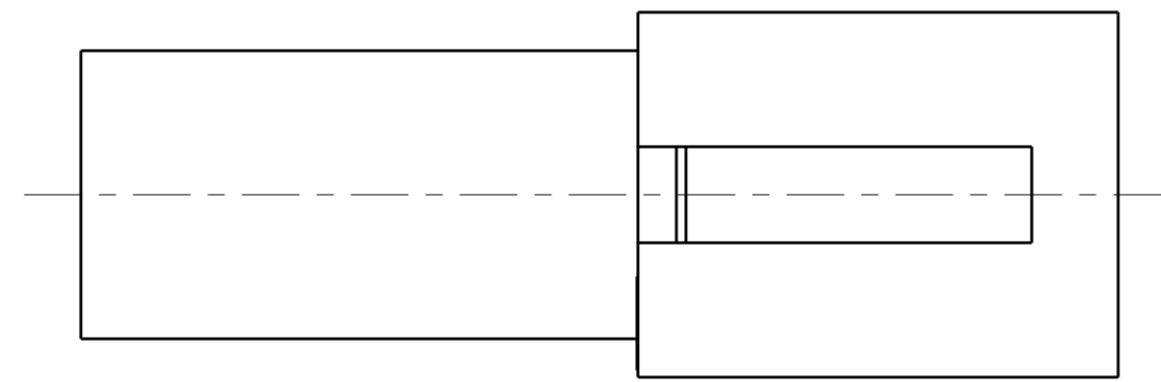

DETAIL A
OPTIONAL CONSTRUCTIONS

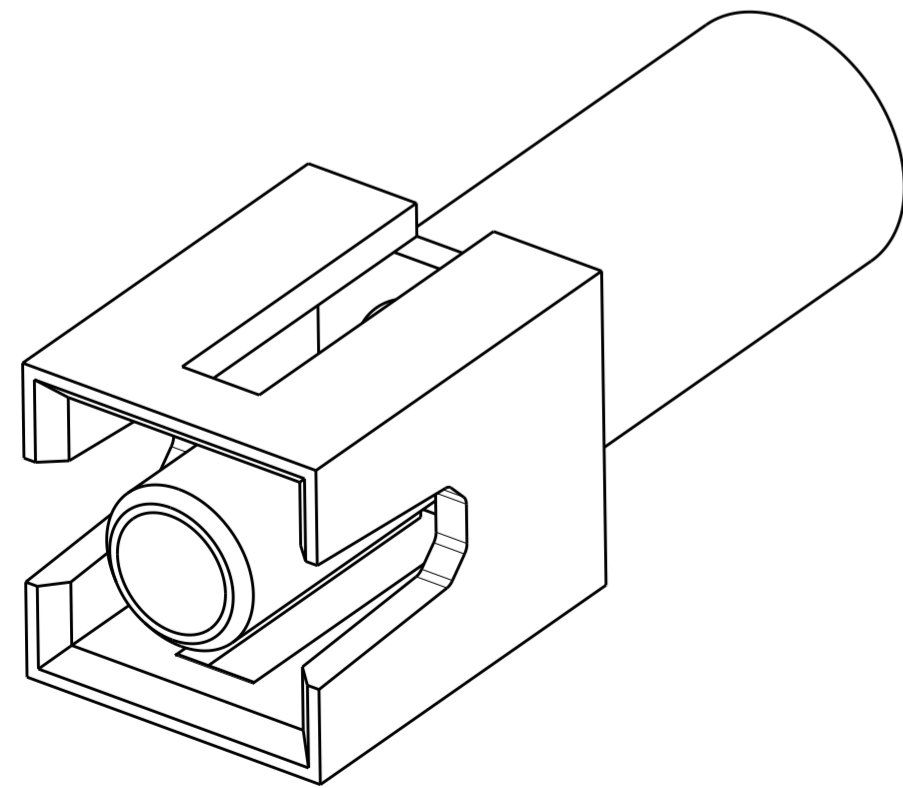

6	NATURAL	1-350866-1
	RED	350866-2
	NATURAL	350866-1
	COLOR	PART NUMBER

THIS DRAWING IS A CONTROLLED DOCUMENT.		DWN B. WEAVER 07MAY2019	TE Connectivity	
DIMENSIONS: mm [IN]		CHK S. FERNANDES 07MAY2019		
TOLERANCES UNLESS OTHERWISE SPECIFIED:		APVD T. BENCHOFF 07MAY2019	NAME CAP, SINGLE CIRCUIT UNIVERSAL MATE-N-LOK	
0 PLC ±	1 PLC ±	PRODUCT SPEC	SIZE	RESTRICTED TO
2 PLC ±0.13 [0.005]	3 PLC ±	APPLICATION SPEC	A2	-
4 PLC ±	ANGLES ±	WEIGHT	CAGE CODE	DRAWING NO
MATERIAL NYLON UL94 V-0	FINISH -	CUSTOMER DRAWING	A200779	C-350866
			SCALE 5:1	SHEET 1 OF 1
			REV P9	