

REVISIONS					
P	LTR	DESCRIPTION	DATE	DWN	APVD
	F	PRODUCTION ISSUE	30JAN2019	PNT	MT

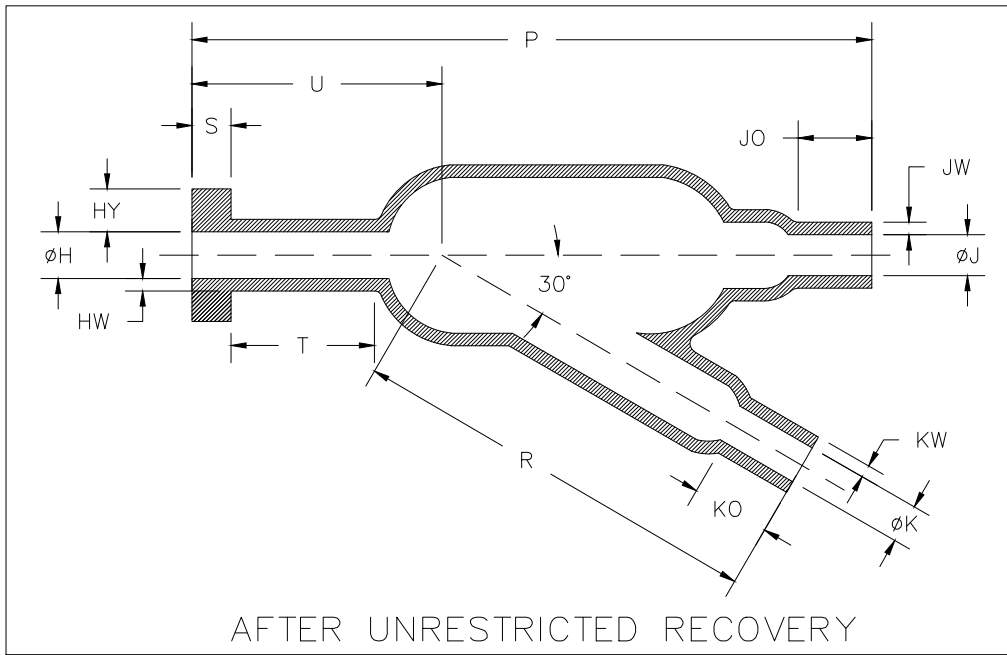
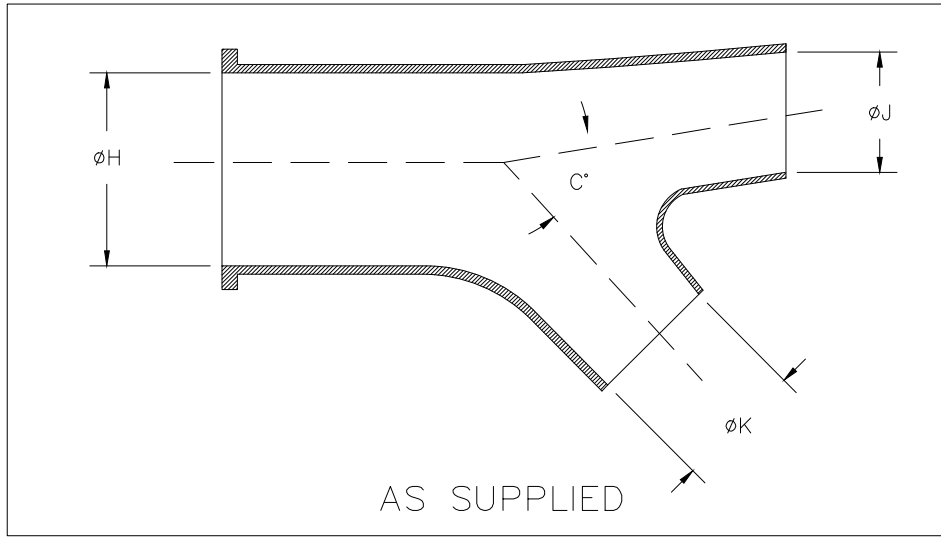

TABLE OF DIMENSIONS

PART NUMBER	H		J		K		P	R	S	T	U	HY	HW	JO	JW	KO	KW	C°
	Min	Max	Min	Max	Min	Max												
	a	b	a	b	a	b												
362W204	26.0 [1.02]	6.3 [.25]	18.0 [.71]	5.3 [.21]	18.0 [.71]	5.3 [.21]	90.0 [3.54]	56.0 [2.20]	5.0 [.20]	18.5 [.73]	34.0 [1.34]	5.5 [.22]	2.5 [.10]	11.0 [.43]	2.0 [.08]	11.0 [.43]	2.0 [.08]	30

THIS DRAWING IS UNPUBLISHED.

ALL RIGHTS RESERVED.

TE Connectivity Ltd.

THIS DRAWING IS UNPUBLISHED.

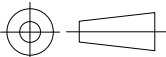
DIMENSIONS: mm [INCHES]	DWN	30JAN2019	MATERIAL	SEE SHEET 2	FINISH	-
	CHK	PRAVEEN N T	30JAN2019	 TE Connectivity Ltd.		
TOLERANCES UNLESS OTHERWISE SPECIFIED:	APVD	N NAGAR	30JAN2019			
	PRODUCT SPEC	M TAYLOR	30JAN2019	NAME TRANSITION, 30 DEGREE, SIDE BREAKOUT		
0 PLC ± -	APPLICATION SPEC	-	SIZE	A4	CAGE CODE	00779
1 PLC ± 0.50[.1]	WEIGHT	-	DRAWING NO	C= 362W204-XX-0		RESTRICTED TO
2 PLC ± 0.25[.01]		CUSTOMER DRAWING	SCALE	DNS		SHEET
3 PLC ± 0.13[.005]			1	OF	2	REV
4 PLC ± -						
ANGLES ± 5°						

REVISIONS				
P	LTR	DESCRIPTION	DATE	APVD
	-	SEE SHEET 1	-	-

COMPATABILITY CHART				
MATERIAL DASH NO.	MATERIAL DESCRIPTION	RT SPEC	COATING SLASH NO.	COATING S NO.
-25	Elastomer, Fluid Resistant	RW-2070	/42;/86;/225	S1017;S1048;S1206

ORDERING INFORMATION

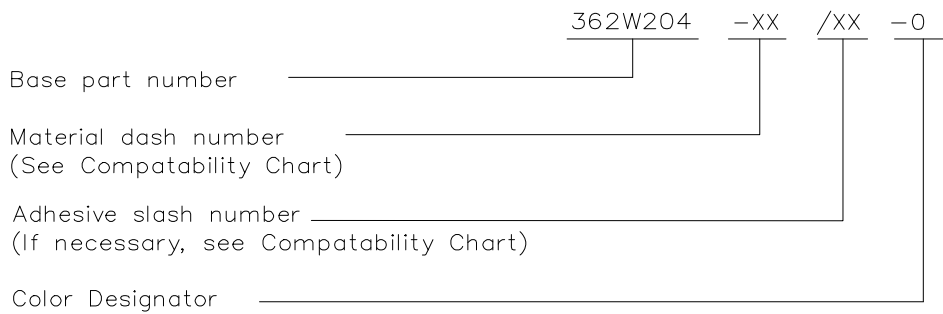

NOTES

- Dimensions appearing in table are as follows:
 - a - As Supplied
 - b - After Unrestricted Recovery
- Coating is optional. As supplied dimensions appearing in table are for uncoated parts. When coating is added, entry diameters will be reduced by 1.5mm[.06]max.

RELEASED FOR PUBLICATION

ALL RIGHTS RESERVED.

© COPYRIGHT - TE Connectivity Ltd.

THIS DRAWING IS UNPUBLISHED.

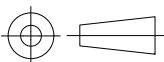
DIMENSIONS: mm [INCHES]	DWN PRAVEEN N T 30JAN2019	MATERIAL -	FINISH -
	CHK N NAGAR 30JAN2019	 TE Connectivity Ltd.	
TOLERANCES UNLESS OTHERWISE SPECIFIED:	APVD M TAYLOR 30JAN2019		
0 PLC ± -	PRODUCT SPEC -	SIZE A4	CAGE CODE 00779
1 PLC ± 0.50[.1]	APPLICATION SPEC -	DRAWING NO C-362W204-XX-0	RESTRICTED TO -
2 PLC ± 0.25[.01]			
3 PLC ± 0.13[.005]			
4 PLC ± -			
ANGLES ± 5°	WEIGHT		
	CUSTOMER DRAWING	SCALE DNS	SHEET 2 OF 2
			REV F