

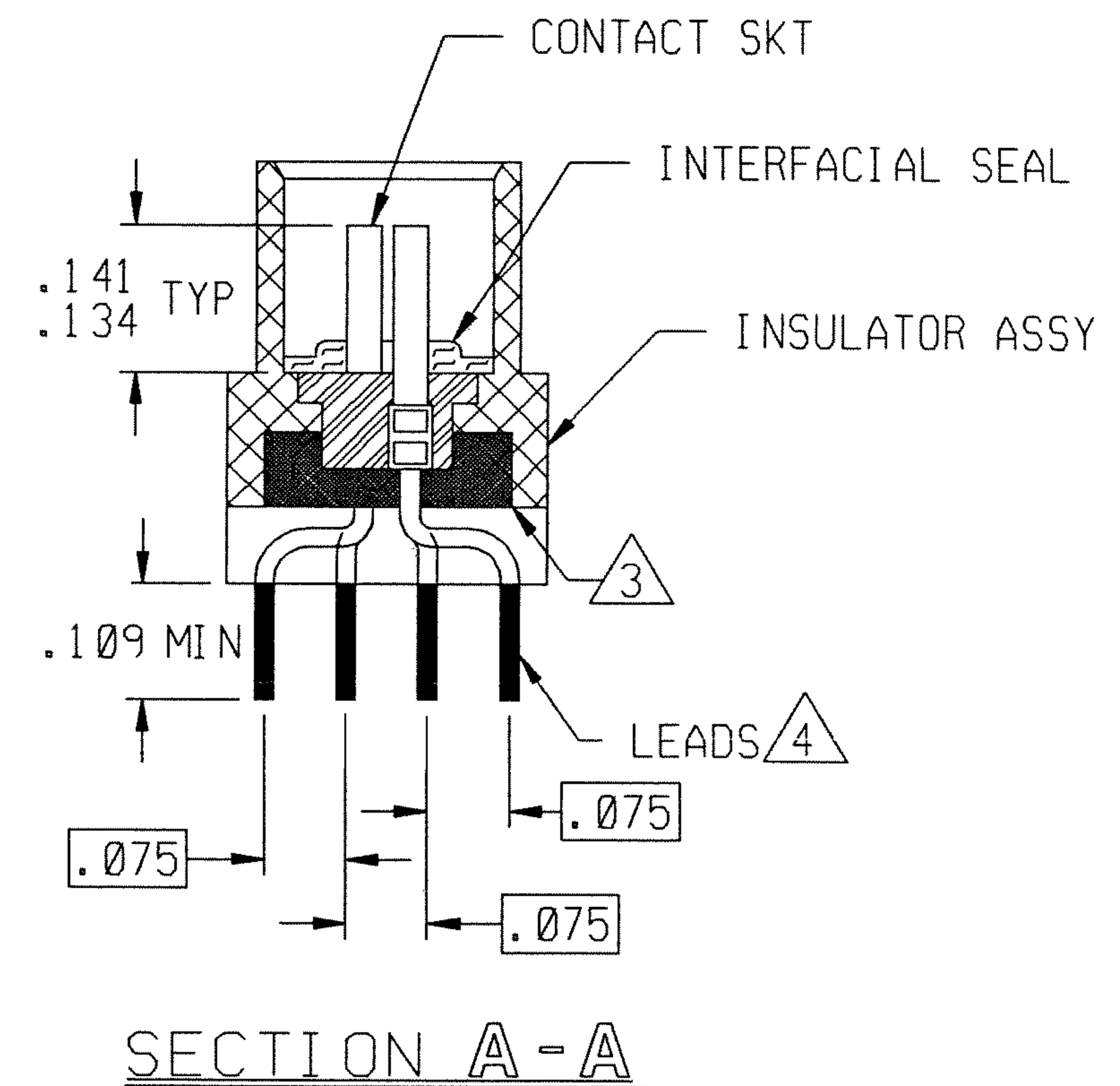

REVISION					
ZONE	LTR	ECN	DESCRIPTION	DATE	APPROVED
	B	38334	UPDATE CONN. DESCRIPTION.	11/20/83	<i>[Signature]</i>
	C		UPDATE PER ECO-10-017486	8/25/10	PJS

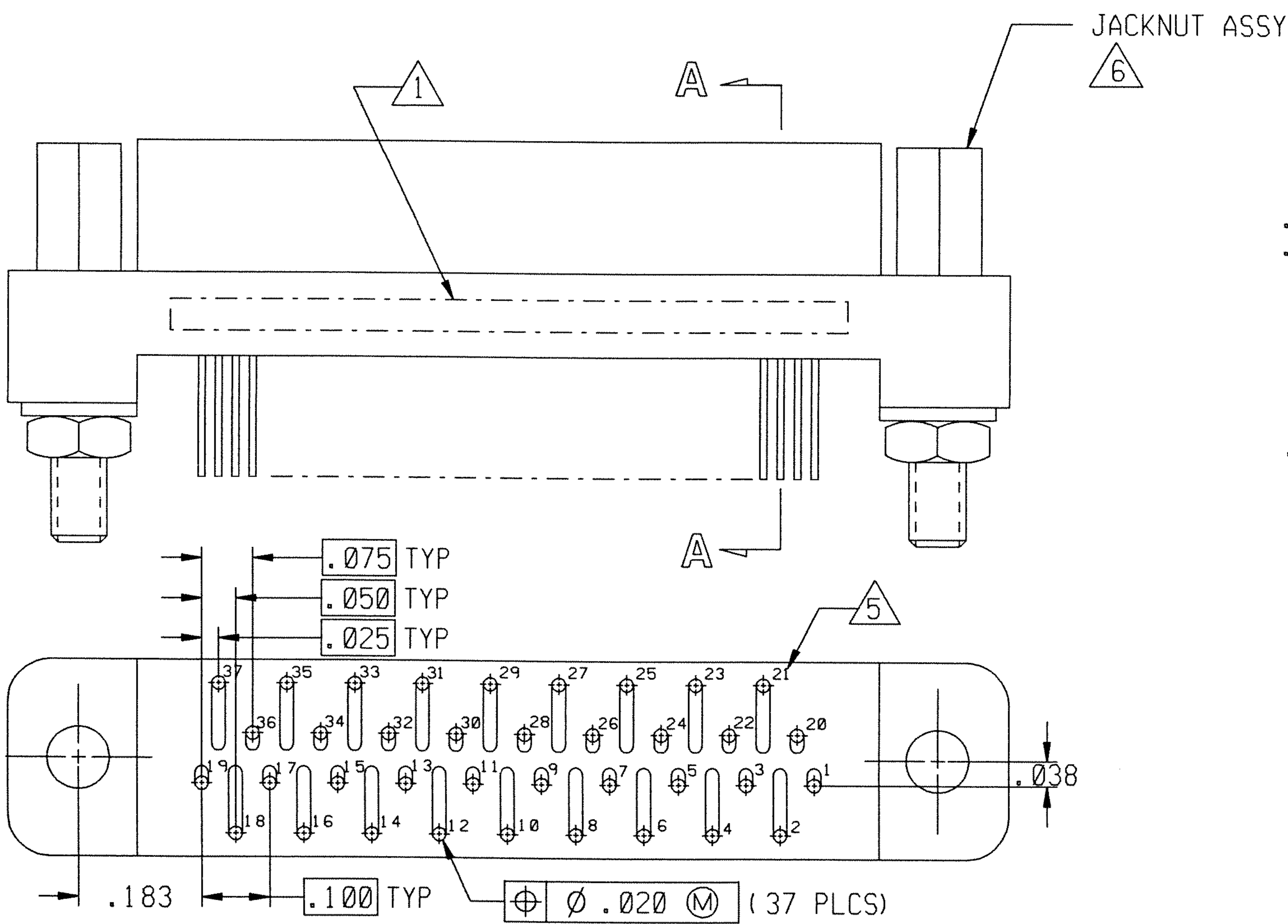
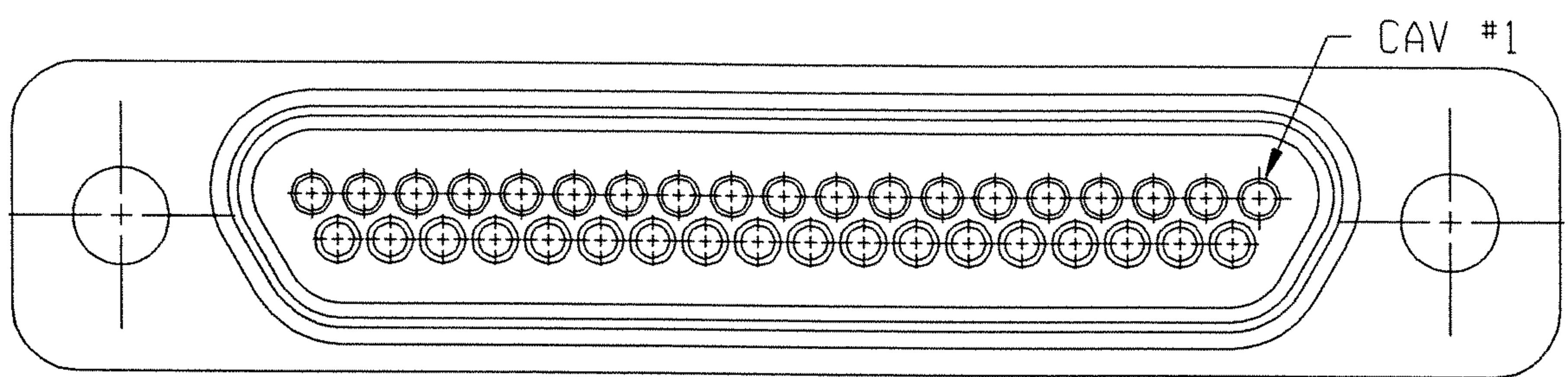

- NOTES: UNLESS OTHERWISE SPECIFIED
- 1. MARK PER MEP 203-12 IN APPROX. LOCATION SHOWN
 - 2. CRIMP LEADS INTO CONTACTS PER MEP 302-05.
 - 3. EPOXY AS SHOWN.
 - 4. TERMINAL WIRES ARE TO BE SOLDER DIPPED UP TO THE MOUNTING SURFACE MINIMUM.
 - 5. LEAD IDENTIFICATIONS ARE FORE REF ONLY. DO NOT APPEAR ON THE PART.
 - 6. JACKNUT ASSEMBLIES ARE INSTALLED ONTO CONNECTOR.

UNLESS OTHERWISE SPECIFIED DIMENSIONS ARE IN INCHES. TOLERANCE ARE: FRACTIONS DECIMALS ANGLES ± 1/8 .XX ± .01 ± 2° .XXX ± .005	APPROVALS		 MICRODOT CONNECTORS A DIVISION OF UNI-STAR INDUSTRIES INC. 306 PASADENA AVE., SO. PASADENA, CA 91030	PROD CODE 845 CODE M
	SIGNATURE	DATE		
MATERIAL:	DRAWN	<i>[Signature]</i>	METAL SHELL "D" CONNECTOR RCPT MCK-**-P-37SST2 094-5607-7001	SIZE CODE IDENT NO. DRAWING NO. B 98278 4-1532223-0
	CHECKED			
	PRO. ENG.			
FINISH:	APPROVED		SCALE: NONE	SHEET 1 OF 1

4

3

2

1