

THIS DRAWING IS UNPUBLISHED. RELEASED FOR PUBLICATION 20
 © COPYRIGHT 20 BY - ALL RIGHTS RESERVED.

REVISIONS				
P	LTR	DESCRIPTION	DATE	APVD
C		ECR-16-010163	15JUL2016	VS DB

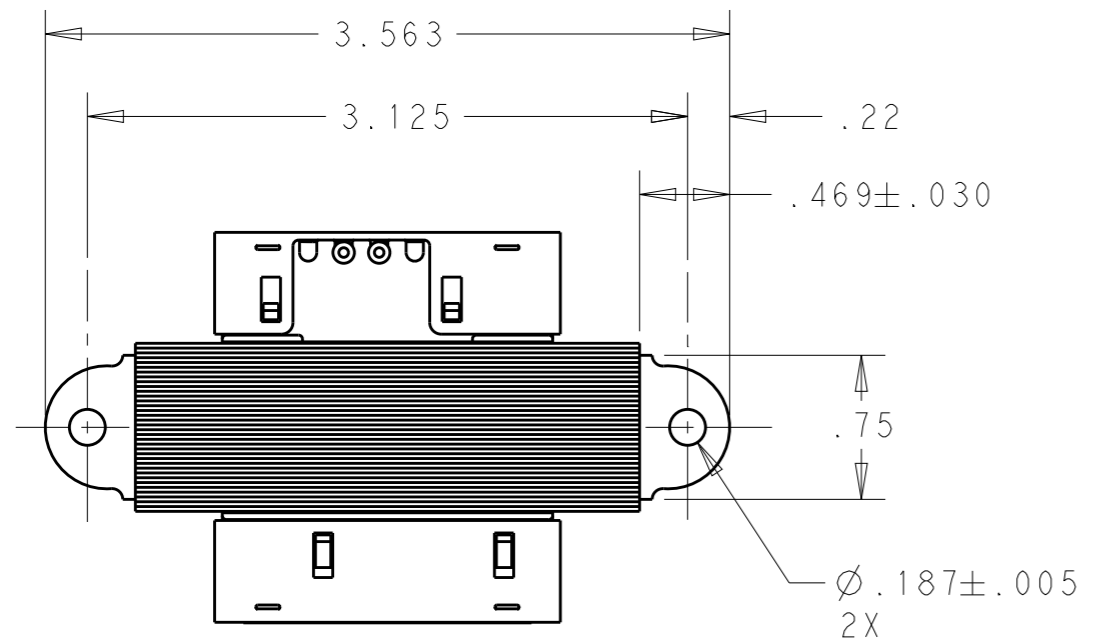

CERTIFICATION: UL & cUL FILE NO. E87824

PRIMARY			SECONDARY			
LEAD NO.	1	2	3	LEAD NO.	6	7
VOLTAGE	COM	208	240	VOLTAGE	24	VAC
COLOR	BLK	RED	ORG	COLOR	BLU	YEL
LENGTH	12.0	12.0	12.0	LENGTH	12.0	12.0
STRIP LENGTH	.50			STRIP LENGTH	.50	

1. ALL LEADS ARE 18AWG UNLESS OTHERWISE SPECIFIED AND HAVE A TOLERANCE OF +1.0/-0
2. STRIP TOLERANCE IS ±1/32.
3. WINDING PROTECTION: INHERENTLY LIMITING.

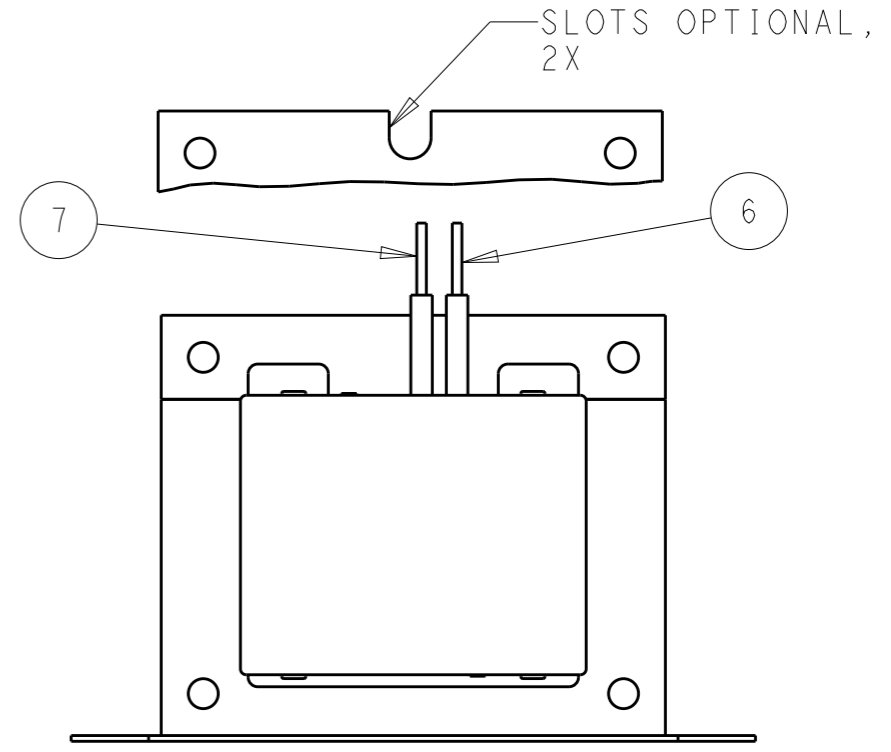
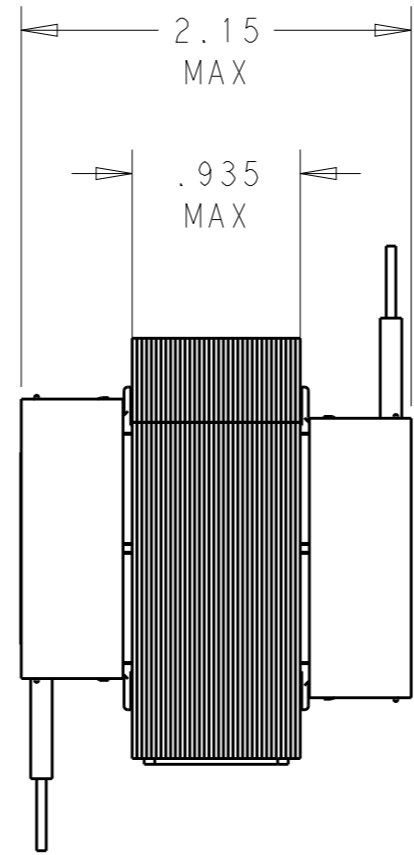
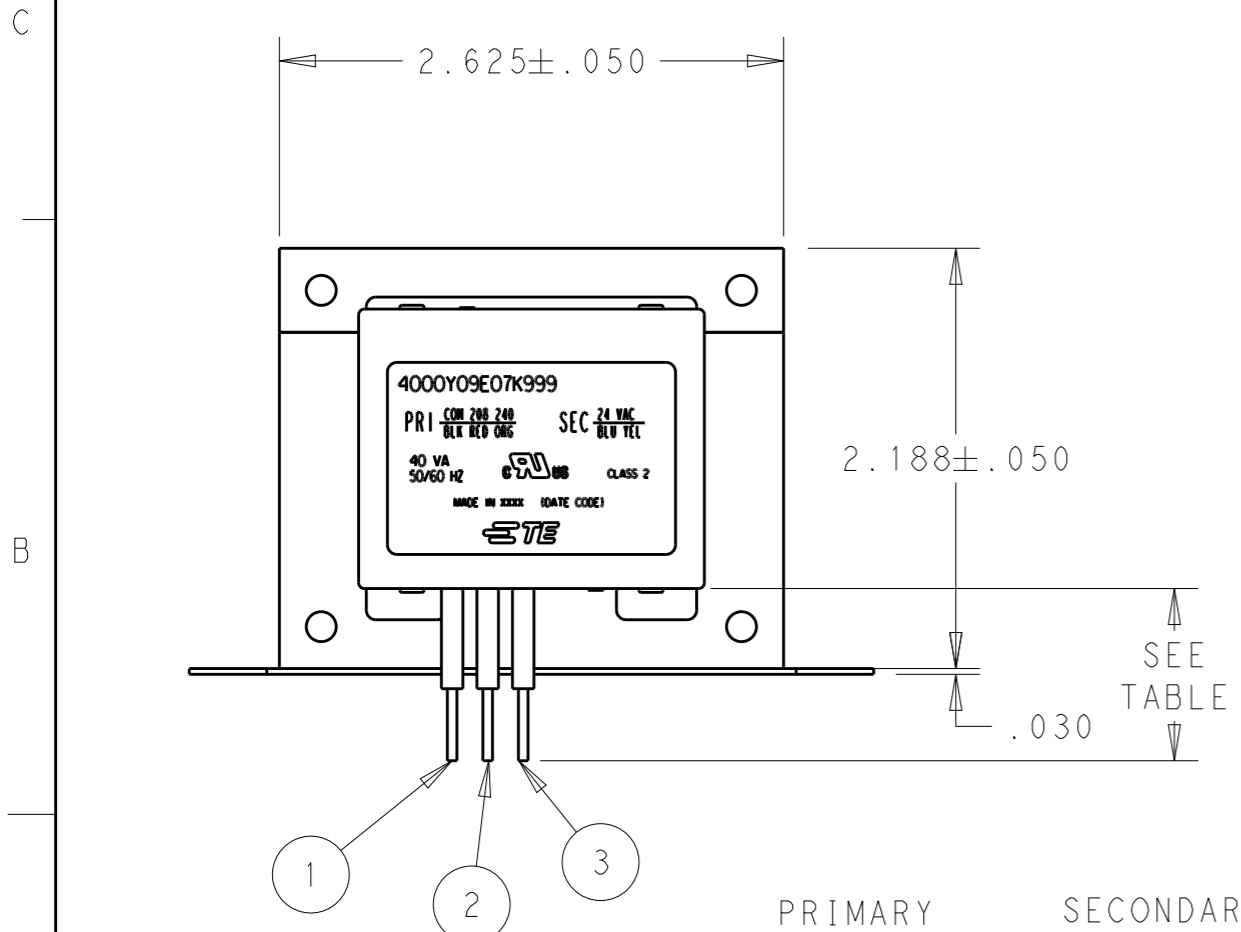

2-1611457-5
TE PART NO.

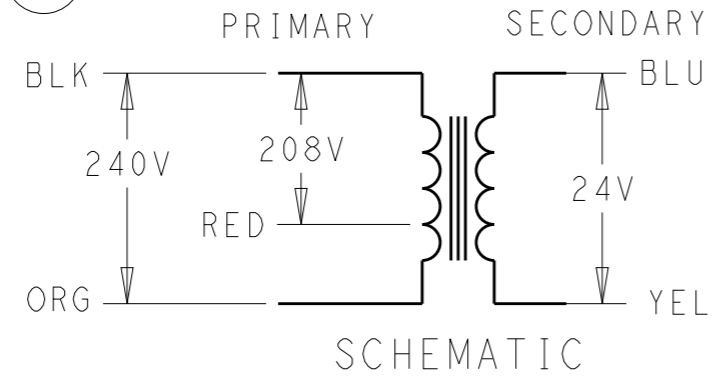

THIS DRAWING IS A CONTROLLED DOCUMENT.

DIMENSIONS: INCHES	TOLERANCES UNLESS OTHERWISE SPECIFIED:
	0 PLC ±-
	1 PLC ±.1
	2 PLC ±.03
	3 PLC ±.015
	4 PLC ±-
	ANGLES ±-
MATERIAL	FINISH
-	-

DWN VIC SLACK 15JUL2016	TE Connectivity NAME TRANSFORMER OUTLINE SIZE A3 CAGE CODE - DRAWING NO C-4000Y09E07K999 RESTRICTED TO - SCALE 1:1 SHEET 1 OF 1 REV C
CHK D. BLOESCH 15JUL2016	
APVD D. BLOESCH 15JUL2016	
PRODUCT SPEC - APPLICATION SPEC - WEIGHT -	
CUSTOMER DRAWING	