

THIS DRAWING IS UNPUBLISHED. RELEASED FOR PUBLICATION
 © COPYRIGHT BY TYCO ELECTRONICS CORPORATION. ALL RIGHTS RESERVED.

Loc	DIST	REVISIONS			
P	LTR	DESCRIPTION	DATE	DWN	APVD
AJ	16	A	EC 0K40-0823-02	30AUG02	JRB LLV

- 1 PHOSPHOR BRONZE PER QQ-B-750.
- 2 HOT AIR LEVEL TIN-PLATE, .000100 MIN THICK.
- 3 CRIMP TOOLING: AMP-O-LECTRIC 354500-1 WITH APPLICATOR 466689-2.
- 4 CRIMP TOOLING: AMP-O-LECTRIC 354500-1 WITH APPLICATOR 567386-2.
- 5 RG-58/U COAXIAL CABLE, 21 AWG SOLID, 22 AWG STRANDED.
- 6 RG-174/U COAXIAL CABLE.

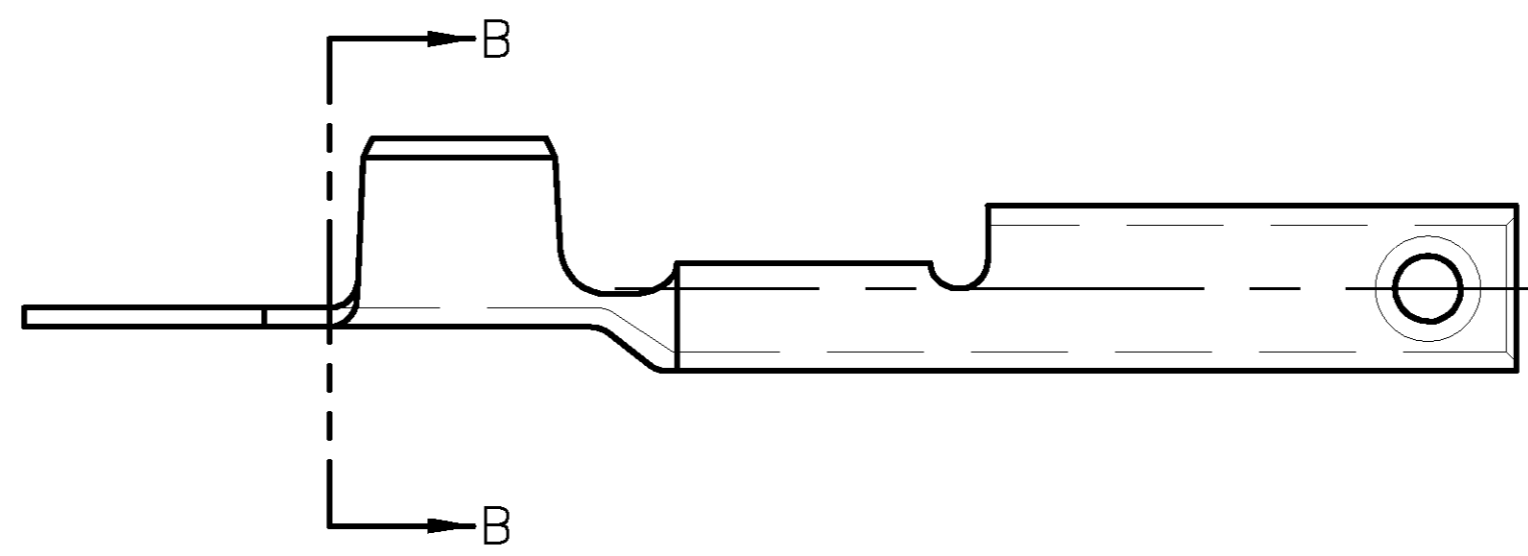
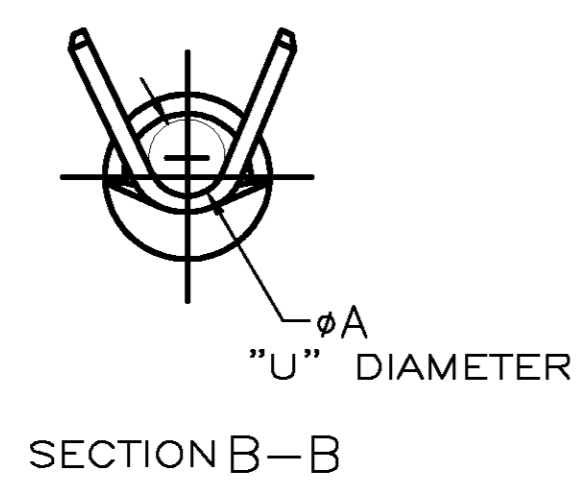
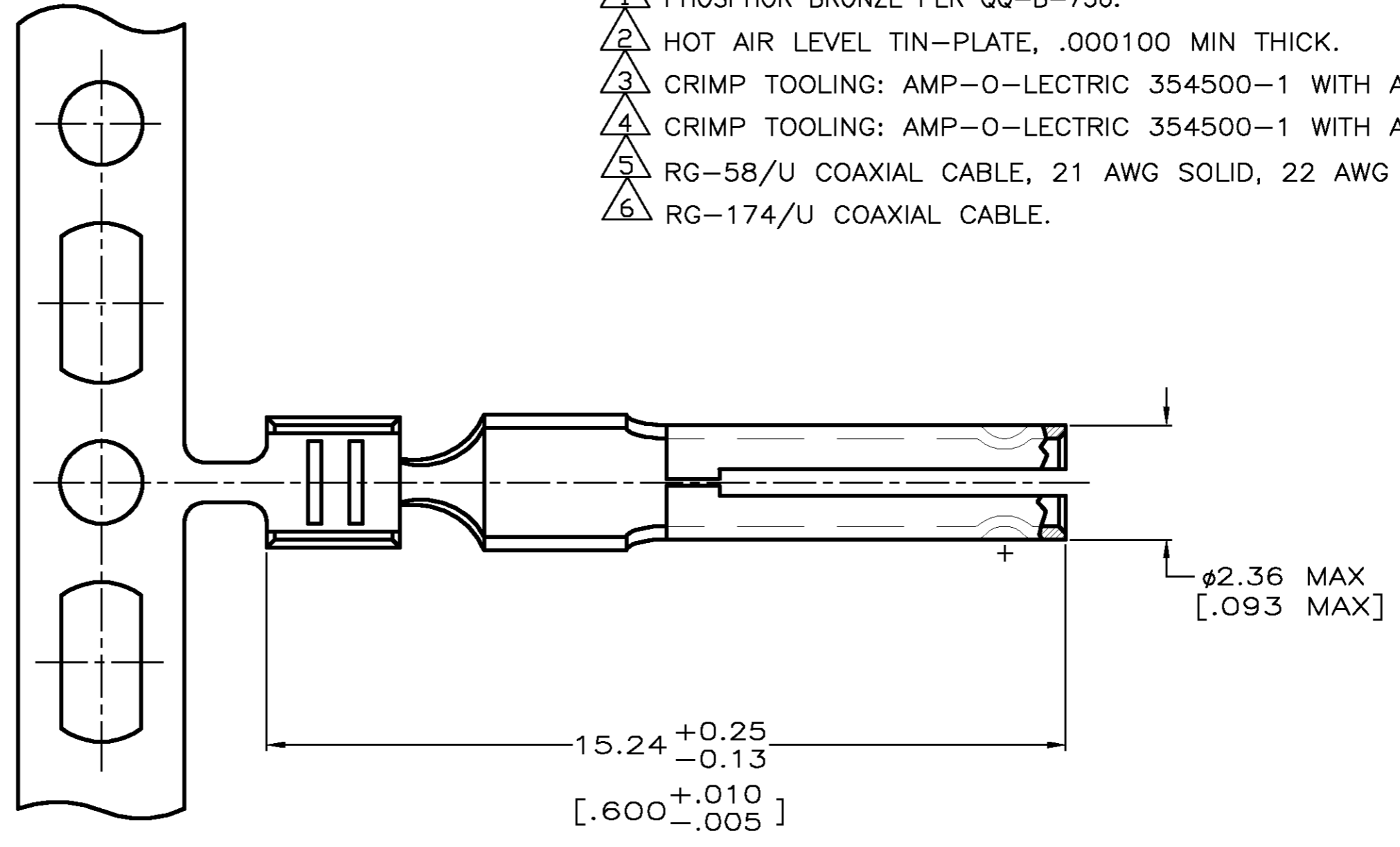

4	6	0.64 [0.025]	415030-3
3	5	1.02 [0.040]	415030-2
USE WITH		A	PART NUMBER

DIMENSIONS:		TOLERANCES UNLESS OTHERWISE SPECIFIED:		APVD		NAME	
MM [INCHES]		0 PLC	± -	B. MOYER	9-11-95	Tyco Electronics Corporation	
		1 PLC	± -	B. GRAY	9-11-95	Harrisburg, PA 17105-3608	
		2 PLC	± 0.13 [0.005]	B. GRAY	9-11-95	RECEPTACLE CONTACT, MINI-UHF	
		3 PLC	± -	PRODUCT SPEC		-	
		4 PLC	± -	APPLICATION SPEC		-	
		ANGLES	± -	WEIGHT		-	
MATERIAL	1?	FINISH	2?	SIZE		A2 00779	
CUSTOMER DRAWING				DRAWING NO		415030	
				SCALE		10:1	
				SHEET		1 OF 1	
				REV		A	

415030

A