

PROJ 3460	LOG DF	DIST X0	P	F	REVISIONS						
					ZONE	LFR	DESCRIPTION	DATE	APPD		
							D	RELEASED PER NPR 92-395	CT	10-92	CS
							A	REV PER DF-7398	TT	05-93	CS
							B	REV PER 0600-0491-93	TA	7-15-93	CS

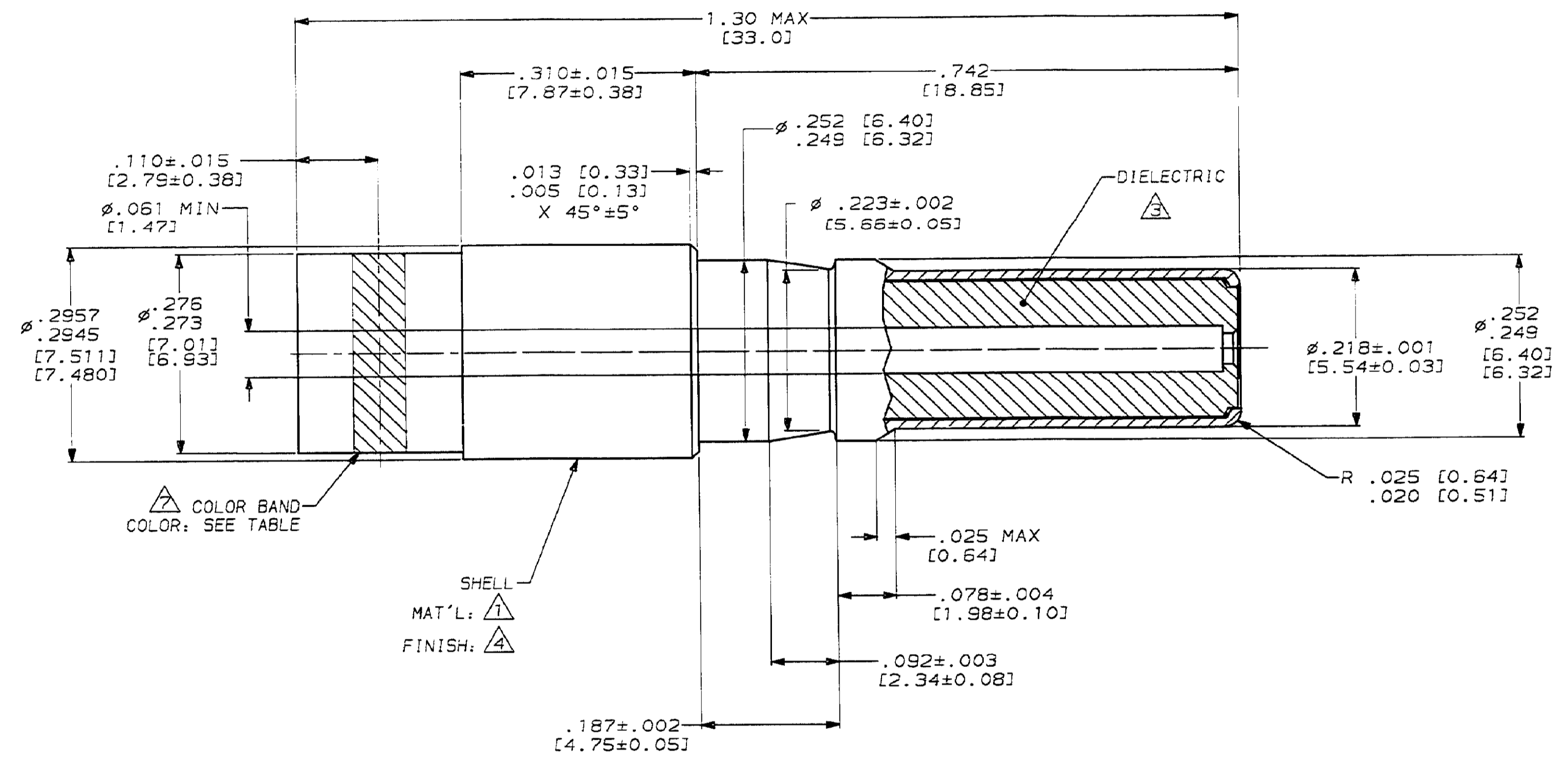
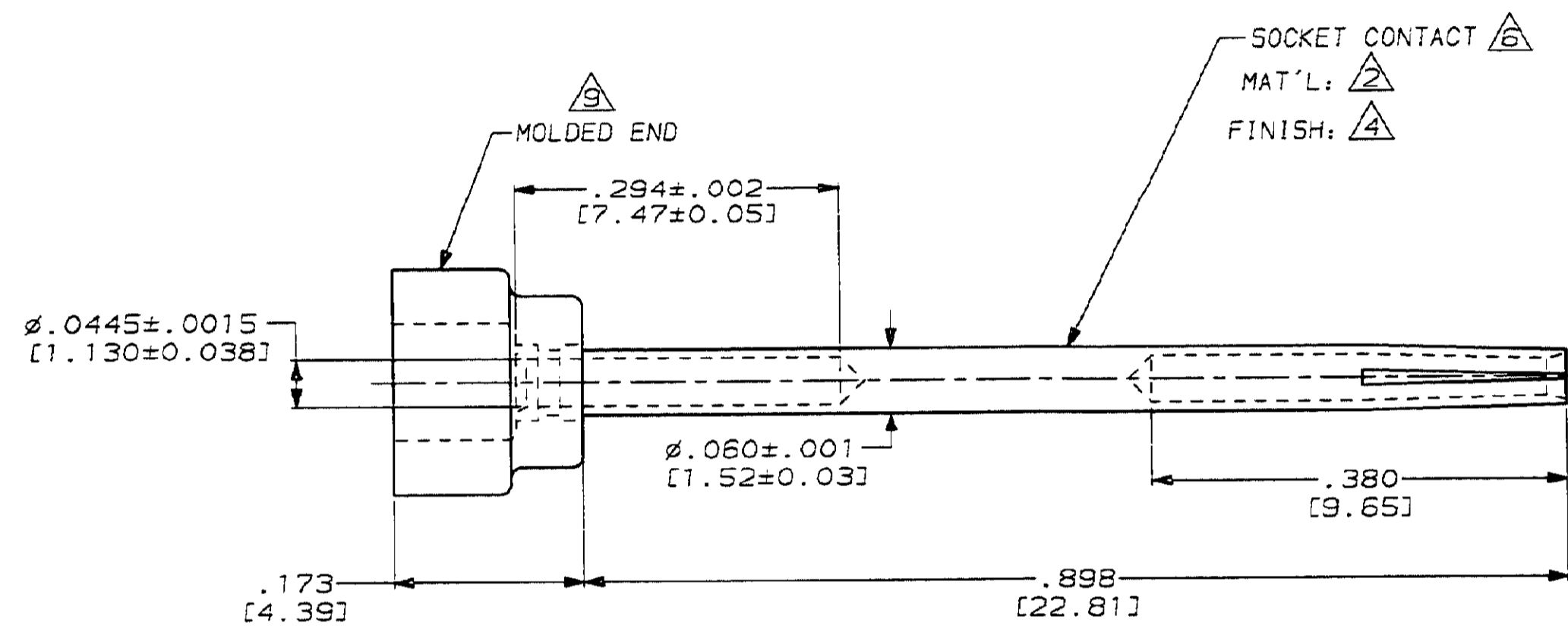
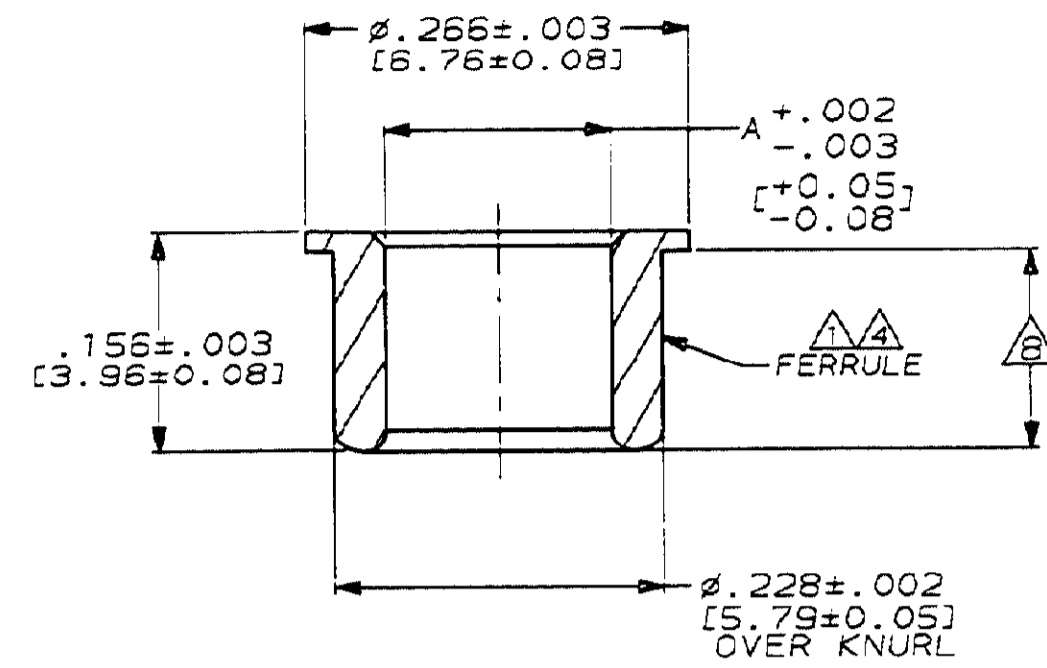

- △ MAT'L: BRASS PER ASTM-B-16
- △ MAT'L: BERYLLIUM COPPER PER ASTM-B-196.
- △ MAT'L: PTFE PER ASTM-D-1710.
- △ FINISH: GOLD PLATE PER MIL-G-45204, TYPE 1, GRADE C, CLASS 1 OVER NICKEL .000050 [0.0013] THK PER QQ-N-290, CLASS 2.
- 5. FOR USE WITH ADAMS RUSSELL FC 11Z CABLE. (-1 ONLY)  
FOR USE WITH ADAMS RUSSELL FC 14Z CABLE. (-2 ONLY)
- △ SOCKET CONTACT WILL ACCEPT A .040 [1.02] DIA. PIN.
- △ COLOR CODED PER MIL-C-39029, .020-.050 [0.51-1.27] WIDTH.
- △ 160 DP. FULL DIAMOND KNURL OVER THIS LENGTH.
- △ MAT'L: POLYESTER MLDG. CMPD. PER MIL-M-24519, TYPE C.

DO NOT SCALE PRINT. UNLESS SPECIFIED DIMENSIONS IN INCHES [mm] TOLERANCES ON: 2 PLC DEC = - 3 PLC DEC = .005 [0.13] ANGLES = -	DR 10-22-92 C.C. THOMAS CHK 10-30-92 C. SHELLY APPD 10-30-92 C. SHELLY APPD 10-30-92 C. SHELLY
MATERIAL SEE CALLOUTS	PRODUCT SPEC -
FINISH SEE CALLOUTS	APPLICATION SPEC -
	WEIGHT -

SIZE D	CAGE CODE 00779	DRAWING NO 448542
SCALE 8:1		SHEET 1 OF 1

GREEN	.157 [3.99]	448542-2
RED	.115 [2.92]	448542-1
COLOR	A DIM	PART NO.

<b>AMP</b> AMP Incorporated Harrisburg, PA 17105-3608		
NAME COAX PIN CONTACT ASSEMBLY, FRONT RELEASE, SIZE 8, (ARINC-TRIAx)		
SIZE D	CAGE CODE 00779	DRAWING NO 448542
SCALE 8:1		SHEET 1 OF 1