

SPECIFICATION CONTROL DRAWING

SCD

44AC115+

Title FIVE CONDUCTOR CABLE, SHIELDED, JACKETED,
GENERAL PURPOSE, 600 VOLT

Date 8-11-16

Revision A

This specification sheet forms a part of the latest issue of Raychem Specification 44 and NEMA WC 27500, as applicable.

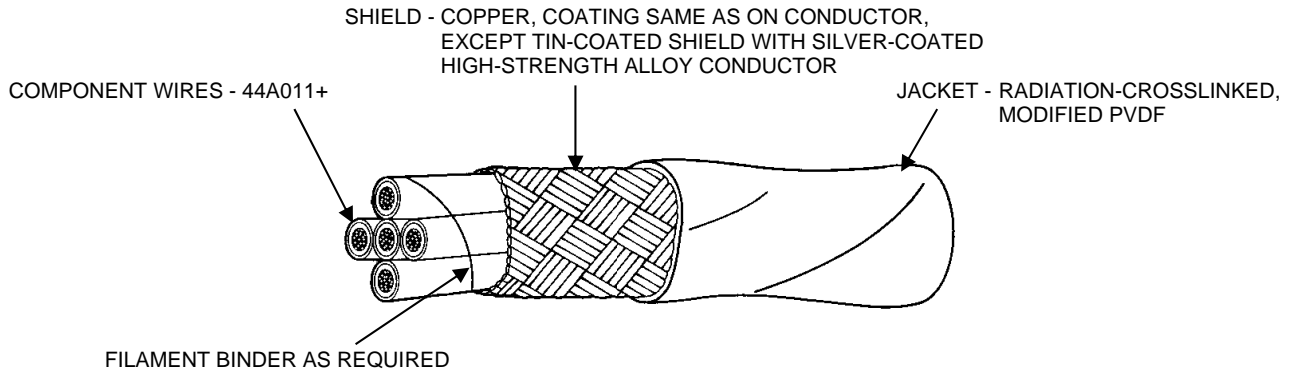

TABLE I. CABLE CONSTRUCTION DETAILS

PART NUMBER 1/	CONDUCTOR SIZE (AWG)	SHIELD SIZE (AWG)	JACKET THICKNESS (inch)		OUTSIDE DIAMETER (inch)		MAXIMUM WEIGHT (lbs/1000 ft.)
			MINIMUM	MAXIMUM	NOMINAL	MAXIMUM	
44AC115+-26-*	26	38	.005	.010	.125	.142	15.4
44AC115+-24-*	24	38	.005	.010	.141	.161	20.2
44AC115+-22-*	22	38	.005	.010	.160	.183	26.8
44AC115+-20-*	20	38	.006	.012	.184	.210	36.7
44AC115+-18-*	18	38	.006	.012	.211	.242	51.2
44AC115+-16-*	16	38	.007	.014	.231	.266	63.1
44AC115+-14-*	14	38	.007	.014	.277	.319	92.5
44AC115+-12-*	12	36	.007	.014	.333	.383	141.

TABLE II. CABLE PERFORMANCE DETAILS

PART NUMBER 1/	BEND TESTING			
	MANDREL DIAMETER (inch) (± 3%)		WEIGHT (lb) (± 3%)	
	IMMERSION AND CROSSLINKED VERIFICATION	COLD BEND	IMMERSION AND CROSSLINKED VERIFICATION	COLD BEND
44AC115+-26-*	3.00	3.00	.625	3.75
44AC115+-24-*	6.00	6.00	.938	3.75
44AC115+-22-*	6.00	6.00	.938	7.50
44AC115+-20-*	6.00	6.00	.938	7.50
44AC115+-18-*	6.00	6.00	1.25	7.50
44AC115+-16-*	6.00	6.00	1.25	7.50
44AC115+-14-*	10.0	10.0	2.50	22.5
44AC115+-12-*	10.0	10.0	2.50	22.5

Nominal values are for information only. Nominal values are not requirements.

Users should evaluate the suitability of this product for their application. Specifications are subject to change without notice.

Tyco Electronics Corporation also reserves the right to make changes in materials or processing, which do not affect compliance with any specification, without notification to Buyer.

1/ COLORS AND COLOR CODE DESIGNATORS SHALL BE IN ACCORDANCE WITH MIL-STD-681. HOWEVER, DUE TO LENGTH LIMITATIONS OF THE RAYCHEM PART NUMBER, AN ALTERNATIVE COLOR CODE MAY REPLACE MIL-STD-681 COLOR CODE DESIGNATORS. (EXAMPLE: "901/902..." MAY BE REPLACED BY "Axxx".) OTHER CODES AND SUFFIXES MAY BE ADDED TO THE PART NUMBER, AS NECESSARY, TO CAPTURE ANY ADDITIONAL REQUIREMENTS IMPOSED BY THE PURCHASE ORDER.

Raychem, TE Connectivity, TE connectivity (logo), and TE (logo) are trademarks.

DIMENSIONS ARE IN INCHES AND, UNLESS OTHERWISE DESIGNATED, ARE NOMINAL

THIS SPECIFICATION SHEET TAKES PRECEDENCE OVER DOCUMENTS REFERENCED HEREIN. REFERENCED DOCUMENTS SHALL BE OF THE ISSUE IN EFFECT ON DATE OF INVITATION FOR BID.



Raychem Wire & Cable
501 Oakside Avenue
Redwood City, CA 94063-3800
Phone: 1-800-522-6752
Fax: 1-650-361-6297



CABLE RATINGS AND ADDITIONAL REQUIREMENTS

TEMPERATURE RATING: 150°C

Maximum continuous conductor temperature

VOLTAGE RATING: 600 volts (rms) at sea level

BLOCKING: 150 ± 3°C for 6 hours

CROSSLINKED VERIFICATION: 200 ± 5°C for 6 hours

DIELECTRIC WITHSTAND: 1500 volts (rms), 60 Hz,
15 seconds (minimum), 30 seconds (maximum)

FLAMMABILITY: 30 seconds (maximum), 3 inches (maximum); no flaming of facial tissue

IMMERSION: Diameter increase 5% (maximum); no cracking, no dielectric breakdown

JACKET COLOR: White preferred

JACKET CONCENTRICITY: 70% (minimum)

JACKET ELONGATION AND TENSILE STRENGTH:

Elongation, 200% (minimum)

Tensile Strength, 4000 lbf/in² (minimum)

JACKET FLAWS:

Spark Test, 1.5 kV (rms)

Impulse Dielectric Test, 6.0 kV (peak)

LOW TEMPERATURE-COLD BEND: -55 ± 5°C for 4 hours

SHIELD COVERAGE: 90% (minimum)

VOLTAGE WITHSTAND (Post Environmental): 1000 volts (rms), 60 Hz, 1 minute

1/ PART NUMBER:

The "+" in the part numbers in Tables I and II shall be replaced with a conductor material designator as follows:

- 1 tin-coated copper
- 2 silver-coated copper
- 3 nickel-coated copper
- 4 silver-coated high-strength copper alloy (AWG 26-16 only)
- 6 nickel-coated high-strength copper alloy (AWG 26-20 only)

The "*" in the part numbers in Tables I and II shall be replaced by color code designators with a slash separating the component wire colors and a dash separating the component wire colors from the jacket color. Colors shown do not necessarily reflect the sequence of manufacturing.

Example: AWG 20, tin-coated copper conductors; red, orange, green, blue, and white component wires; white jacket: 44AC1151-20-2/3/5/6/9-9