

REVISIONS					
P	LTR	DESCRIPTION	DATE	DWN	APVD
	3	PRODUCTION ISSUE	04FEB2019	PNT	MT

a) Part as supplied

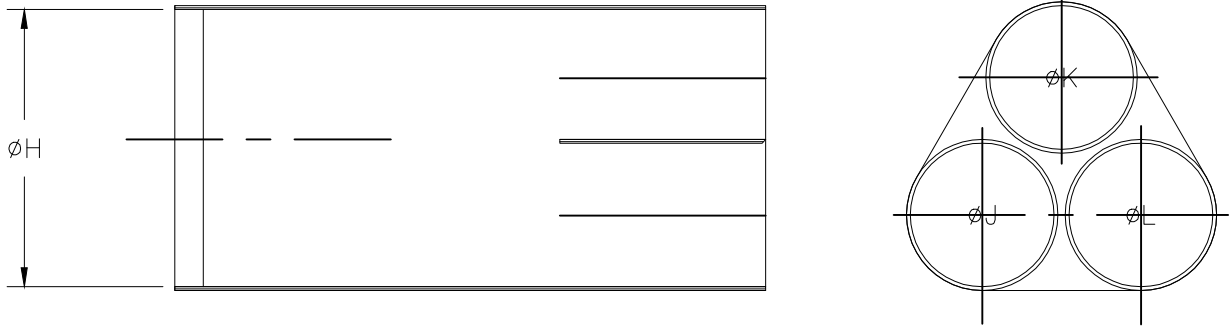

b) Part after unrestricted recovery

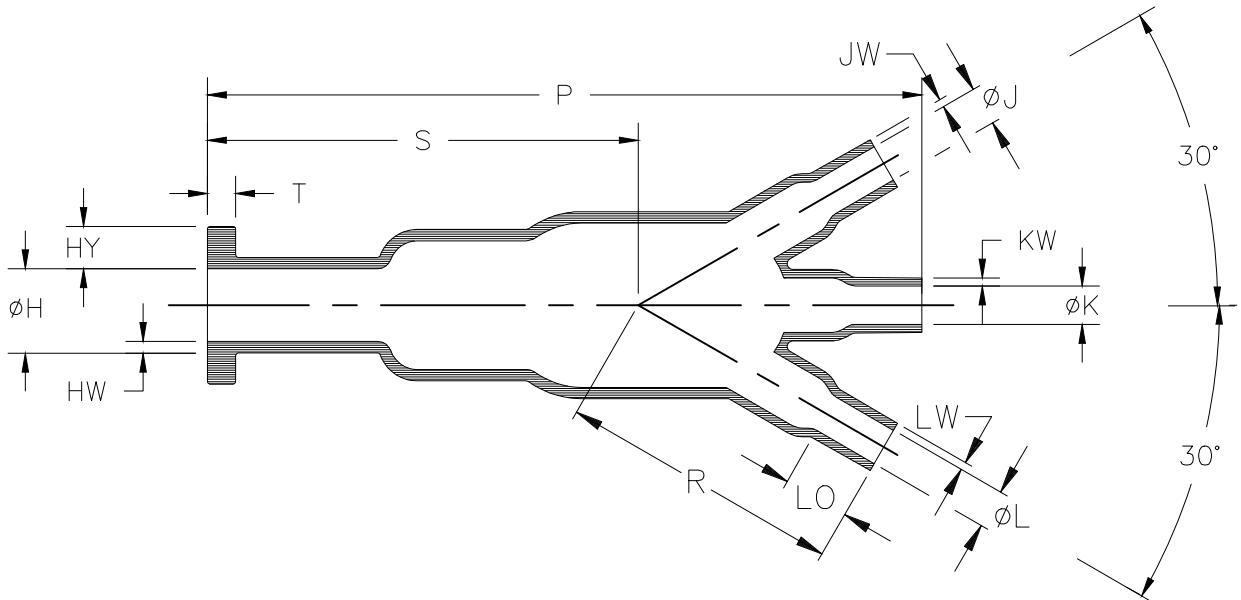

DIMENSIONS

Part No.	H		J, K, L		P	R	S	T	LO	HY	HW	JW, KW, LW
	Min	Max	Min	Max	±10%	±10%	±10%	±20%	±10%	±20%	±20%	±20%
	a	b	a	b	b	b	b	b	b	b	b	b
462W232	40 [1.57]	12.8 [.50]	20 [.79]	6.9 [.27]	128 [5.04]	50 [1.97]	76 [3.0]	5.0 [.196]	12 [.47]	7.0 [.28]	2.0 [.08]	1.5 [.06]

RELEASED FOR PUBLICATION

ALL RIGHTS RESERVED.

COPYRIGHT - TE Connectivity Ltd.

THIS DRAWING IS UNPUBLISHED.

DIMENSIONS:
mm[inches]

DWN PRAVEEN N T 04FEB2019
 CHK N NAGAR 04FEB2019
 APVD M TAYLOR 04FEB2019
 PRODUCT SPEC
 APPLICATION SPEC
 WEIGHT -

MATERIAL SEE SHEET 2

FINISH -



TE Connectivity Ltd.

0 PLC	± -
1 PLC	± -
2 PLC	± -
3 PLC	± -
4 PLC	± -
ANGLES	± -

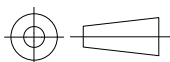

NAME TRANSITION, 1 TO 3 CABLES

SIZE A4 CAGE CODE 00779 DRAWING NO C-382W042-XX-0

RESTRICTED TO -

CUSTOMER DRAWING

SCALE DNS SHEET 1 OF 2 REV 3

REVISIONS				
P	LTR	DESCRIPTION	DATE	APVD
-	-	SEE SHEET 1	-	-

COMPATIBILITY CHART

Material Dash Number	Material Description	RT Spec	Coating Slash No.	Coating S No.
-3	POLYOLEFIN, SEMI-RIGID	RT-301	/42, /86, /180	S1017; S1048; S1030
-4	POLYOLEFIN, FLEXIBLE	RT-1304	/42, /86, /180	S1017; S1048; S1030
-12	FLUOROELASTOMER, FLEXIBLE	RT-1312	N/A	N/A
-25	ELASTOMER, FLUID RESISTANT	RW-2070	/42, /86, /225	S1017; S1048; S1206

Ordering Information

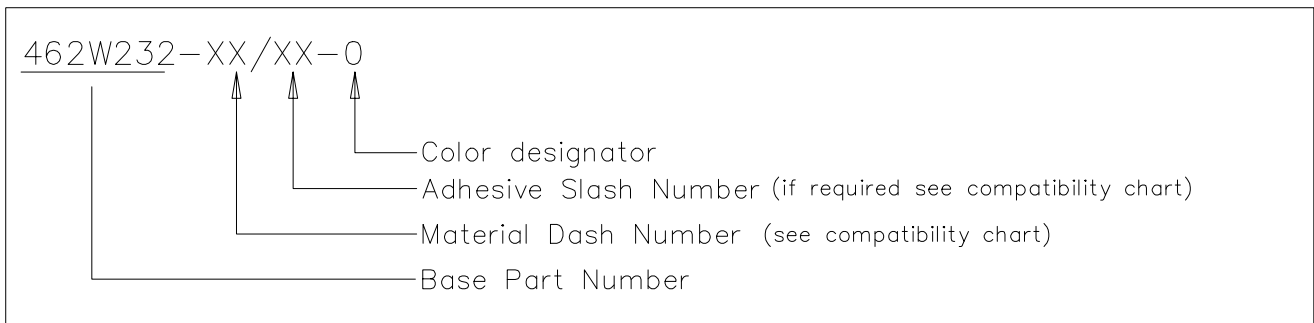

NOTE

- As supplied dimensions are for uncoated parts, when coating is added entry diameters will reduce by 1.5mm[.06] Max.

RELEASED FOR PUBLICATION

ALL RIGHTS RESERVED.

© COPYRIGHT - TE Connectivity Ltd.

THIS DRAWING IS UNPUBLISHED.

DIMENSIONS: mm[inches]	DWN PRAVEEN N T	04FEB2019	MATERIAL SEE SHEET 2	FINISH -
	CHK N NAGAR	04FEB2019	 TE Connectivity Ltd.	
TOLERANCES UNLESS OTHERWISE SPECIFIED:	APVD M TAYLOR	04FEB2019		
0 PLC ± -	PRODUCT SPEC	-	NAME TRANSITION, 1 TO 3 CABLES	
1 PLC ± -	APPLICATION SPEC	-	SIZE A4	CAGE CODE 00779
2 PLC ± -	WEIGHT	-	DRAWING NO C-382W042-XX-0	RESTRICTED TO -
3 PLC ± -			SCALE DNS	
4 PLC ± -			SHEET 2 OF 2	
ANGLES ± -			REV 3	
CUSTOMER DRAWING				

