

REVISIONS		RELEASED	APPROVED
SYM	DESCRIPTION	DATE	
B	21440 REDRAWN, UPDATE NOTES	91/06/18	CG
C	32224 FIND NOS 13 & 14 ADDED	97/03/11	RS

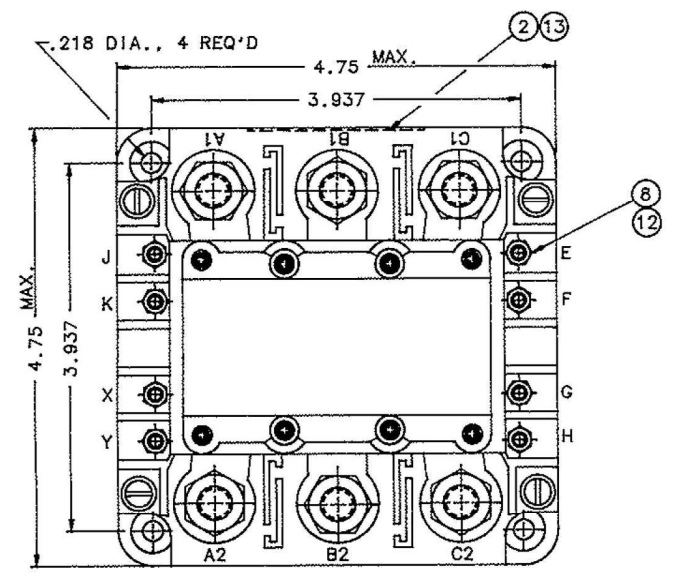

**CONSTRUCTION**  
GASKET SEALED

**MAIN CONTACTS**  
CONFIGURATION: 3PST NO DOUBLE BREAK  
VOLTAGE (NOMINAL): 120/208 V. 270/480 V.  
50, 60, OR 400 HZ 50, 60, OR 400 HZ  
CURRENT RES.: 350 AMP. 100 AMP. MAX.  
MOTOR RUPTURE: 350 AMP. 100 AMP.  
3500 AMP. 1000 AMP.

**AUXILIARY CONTACTS**  
CONFIGURATION: 2PDT  
VOLTAGE: 115 VAC. 50, 60, OR 400 HZ/28 VDC.  
CURRENT RES.: 5 AMP.

**COIL DATA**  
DUTY CYCLE: CONTINUOUS, ECONOMIZING  
NOM. OPERATE VOLTAGE: 115 VAC. 50, 60, OR 400 HZ  
CURRENT: INRUSH .7 AMP MAX.  
HOLD .2 AMP MAX.  
PICKUP MAX. 90 VAC  
DROPOUT VOLTAGE 40 ± 25 VAC  
PICKUP TIME MAX. 100 MILLISEC.  
DROPOUT TIME MAX. 100 MILLISEC.

**ENVIRONMENTAL DATA**  
OPERATE TEMP: -55°C TO +71°C  
LIFE ELECTRICAL: 30,000 CYCLES MIN.  
LIFE MECHANICAL: 50,000 CYCLES MIN.  
WEIGHT: 8 LBS.

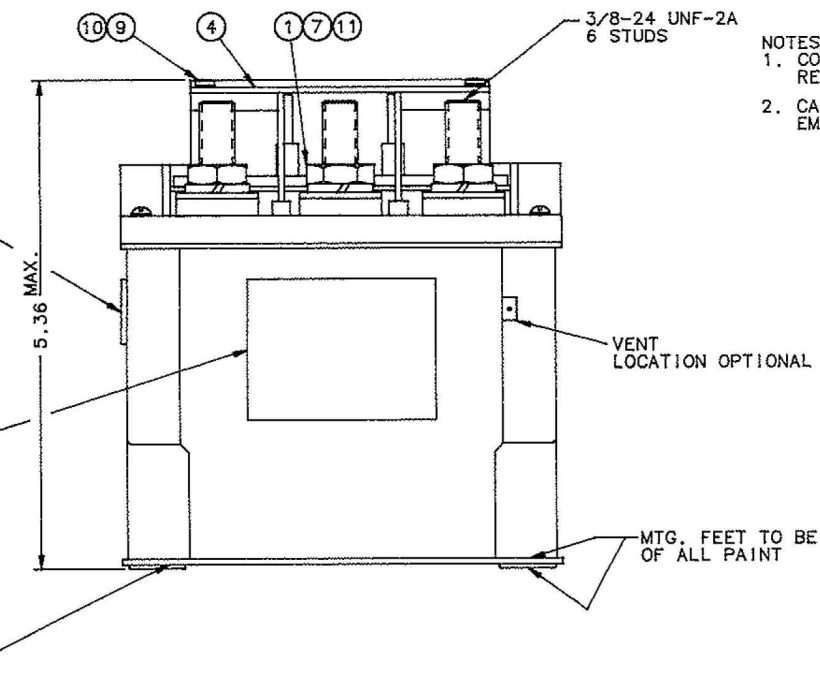
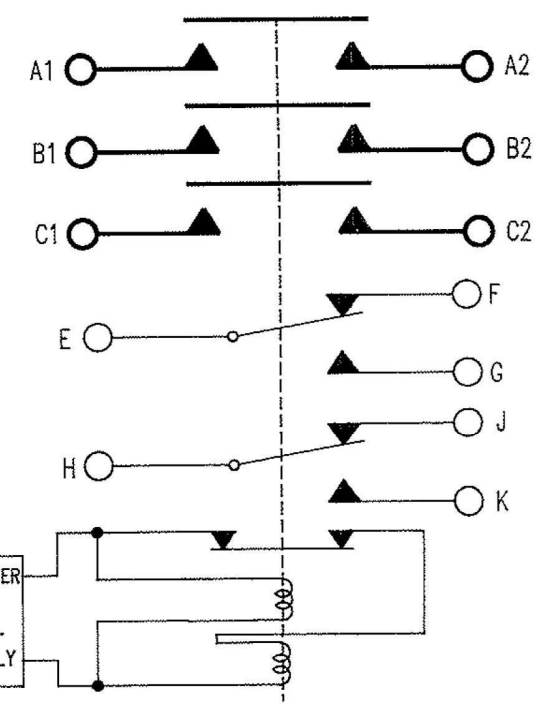

- NOTES:**
- COVER-TERMINAL, ITEM 4, REMOVED FROM TOP VIEW
  - CASE TO PROVIDE GROUND FOR EMI PROTECTION

FIND NO	QTY REQD	PART OR IDENTIFYING NO	NOMENCLATURE OR DESCRIPTION	MATERIAL OR NOTE
14	1	39529-002	OVERLAY-WIRING DIAGRAM	
13	1	39529-001	OVERLAY-NAME PLATE	
12	8	51808-064	WASHER-LOCK NO. 8 SPLIT	BRASS
11	6	51807-084	WASHER-3/8 X .688 X .094 SPLIT	BRASS
10	4	51701-291	WASHER-.250 X .113 X .015	STEEL
9	4	51204-541	SCREW-4-40 X 1/4 BD. HD. SEMS.	STEEL
8	8	50408-014	NUT-8-32 X 1/4 X 3/32 HEX.	BRASS
7	6	50407-164	NUT-3/8-24 X 5/8 X 7/32 HEX.	BRASS
6	1	39506-020	CONTACTOR ASSEMBLY-PR1.	
5	1	39505-001	PLATE-WIRING DIAGRAM	
4	2	28678-001	COVER-TERMINAL	
3	1	25695-001	PLATE-WARNING	
2	1	16043-001	PLATE-NAME	
1	6	09305-001	WASHER-TERMINAL	

UNLESS OTHERWISE SPECIFIED DIMENSIONS ARE IN INCHES TOLERANCES ON

2 PL DEC.	3 PL DEC.	ANGLES
± .06	± .010	± 1°

HARTMAN ELECTRICAL MANUFACTURING  
MANSFIELD, OHIO

CONTACTOR-3PST N.O.  
350 AMP 120/208 V 60 HZ  
5-1616105-4 093

DR BY	RLS	97/03/11
CHK BY	RS	97/03/11
ENGR	WEG	97/03/11
MFG	JAL	97/03/11

RELEASE	SIZE	CODE IDENT	DWG NO.
CONTR NO.	C	74063	BR-301G-4
GOVT APPVL	SCALE	NONE	SHEET