

THIS DRAWING IS UNPUBLISHED. RELEASED FOR PUBLICATION
 © COPYRIGHT BY TYCO ELECTRONICS CORPORATION. ALL RIGHTS RESERVED.

LOC	DIST	REVISIONS					
GP	00	P	LTR	DESCRIPTION	DATE	DWN	APVD
		J		REVISED PER ECO-08-007327	05SEP08	BM	WM

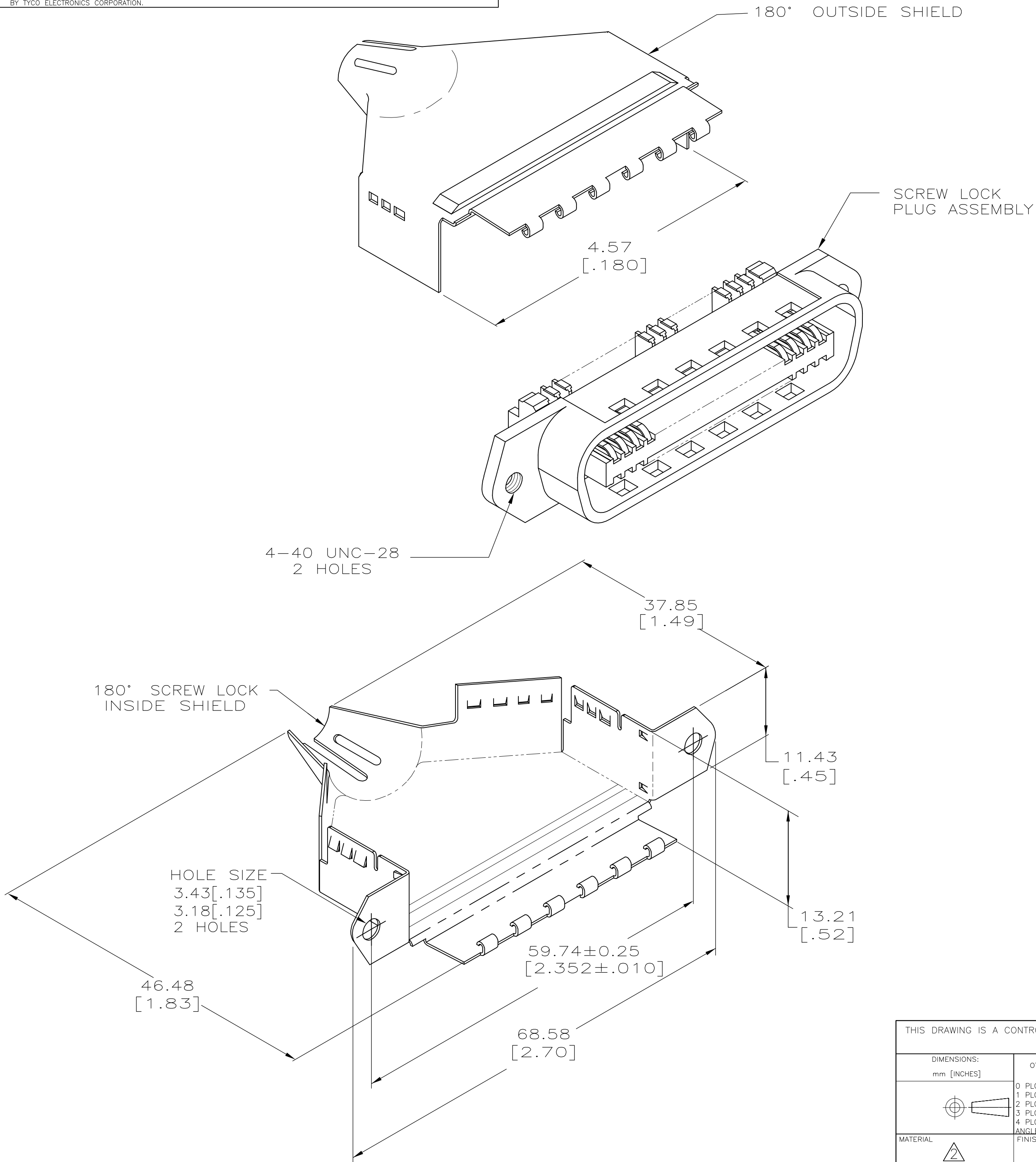

- THIS KIT SHIPPED NOT ASSEMBLED.
- MATERIAL: SHIELDS - BRIGHT NICKEL PLATED CARBON STEEL.
PLUG HOUSING - POLYPHENYLENE OXIDE, BLACK.
TERMINAL - HIGH STRENGTH COPPER ALLOY PLATED WITH 0.76µm [.000030] MIN GOLD OR GOLD FLASH OVER PALLADIUM NICKEL PLATE, 0.76µm [.000030] MIN TOTAL ON MATING SURFACE. 1.27µm [.000050] MIN NICKEL UNDERPLATE OVER ENTIRE TERMINAL.
- WIRE SIZE: 24 OR 26 AWG SOLID OR 24 AWG 7 STRANDS OF COPPER CONDUCTORS. MAXIMUM INSULATION DIAMETER OF 1.14 [.045] IS ACCEPTABLE FOR MOST APPLICATIONS.
- CABLE RANGE: Ø6.35-12.7 [.250-.500].
- CENTER-TO-CENTER SPACING OF TERMINALS 2.16 [.085] NOMINAL.
- WIRE SIZE: 26-27-28 AWG 7 STRANDS OF COPPER CONDUCTORS. MAXIMUM INSULATION DIAMETER OF 1.14 [.045] IS ACCEPTABLE FOR MOST APPLICATIONS.
- DIMENSIONS ARE MAXIMUM UNLESS OTHERWISE SPECIFIED.
- CORING IS AN OPTIONAL CONFIGURATION AND IS AT THE DISCRETION OF AMP.
- OBSELETE

POLY-BAG	B	3	554951-2
	E	6	554951-1
PACKAGED	SLOT SIZE	WIRE SIZE	PART NUMBER

THIS DRAWING IS A CONTROLLED DOCUMENT.		DWN	J. POLIGNONE	10MAR06	Tyco Electronics Corporation Harrisburg, PA 17105-3608
DIMENSIONS: mm [INCHES]		CHK	W. MILLHIMES	10MAR06	
TOLERANCES UNLESS OTHERWISE SPECIFIED:		APVD	W. MILLHIMES	10MAR06	
0 PLC ± - 1 PLC ± - 2 PLC ± - 3 PLC ± - 4 PLC ± - ANGLES ± - FINISH		PRODUCT SPEC	NAME		
MATERIAL		APPLICATION SPEC	PLUG KIT, 36 POSITION, SCREW LOCK, WITH 4-40 HOLES, SHIELDED CHAMP-LOK		RESTRICTED TO
CUSTOMER DRAWING		WEIGHT	A2 00779 C=554951		SCALE
		SCALE	2:1		SHEET
				1 of 1	REV
				J	

554951

A