

REVISIONS				
P	LTR	DESCRIPTION	DATE	DWN APVD
	B	PRODUCTION ISSUE	31JAN2019	PNT MT

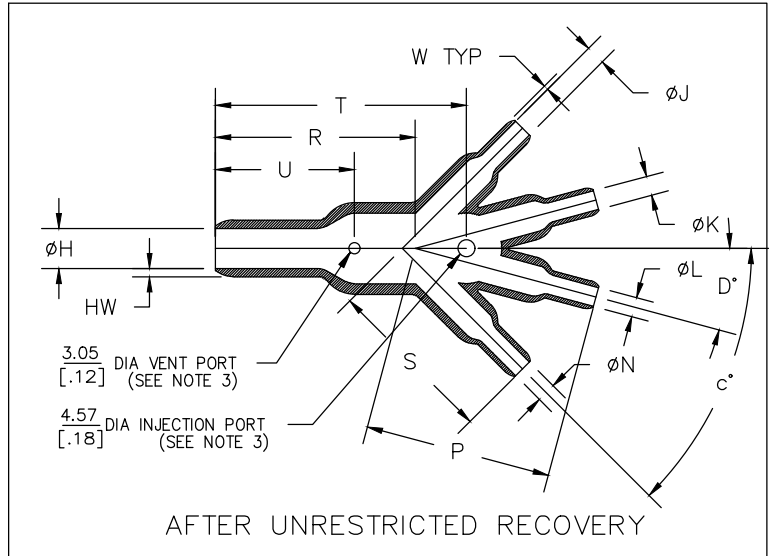
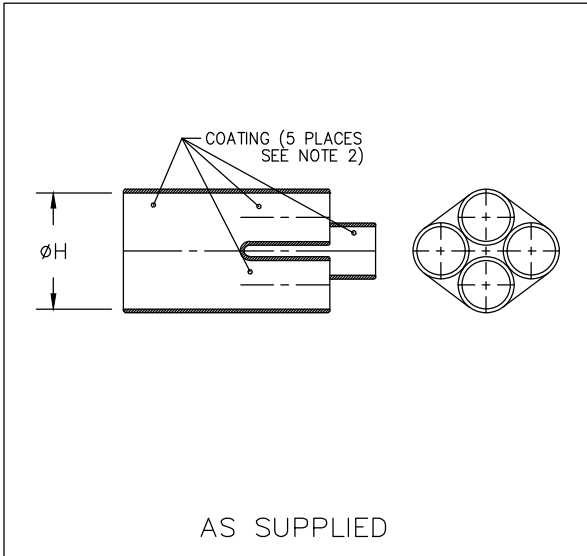

PART NUMBER	H		J,K,L & N		P	R	S	T	U	C°	D°	HW	W
	Min a	Max b	Min a	Max b	±10% b	±10% b	±10% b	±10% b	±10% b	±5% b	±5% b	±20% b	±20% b
562A011-25/225	13.2 [.52]	6.9 [.27]	6.6 [.26]	3.4 [.14]	24.1 [.95]	38.4 [1.51]	24.1 [.95]	43.9 [1.73]	18.0 [.71]	45	15	1.52 [.06]	1.02 [.04]
562A022-25/225	19.3 [.76]	9.7 [.38]	9.4 [.37]	5.3 [.21]	35.6 [1.40]	36.1 [1.42]	32.0 [1.26]	43.2 [1.70]	23.1 [.91]	45	15	1.78 [.07]	1.02 [.04]
562A032-25/225	19.3 [.76]	9.7 [.38]	13.2 [.52]	6.9 [.27]	49.3 [1.94]	36.1 [1.42]	45.0 [1.77]	50.5 [1.99]	25.4 [1.00]	45	15	1.78 [.07]	1.52 [.06]
562A043-25/225	26.9 [1.06]	13.0 [.51]	13.2 [.52]	6.9 [.27]	49.3 [1.94]	51.8 [2.04]	45.0 [1.77]	65.8 [2.59]	33.5 [1.32]	45	15	2.54 [.10]	1.52 [.06]
562A054-25/225	38.6 [1.52]	18.5 [.73]	19.3 [.76]	9.7 [.38]	71.9 [2.83]	74.9 [2.95]	65.3 [2.57]	95.3 [3.75]	46.5 [1.83]	45	15	3.05 [.12]	1.78 [.07]
562A067-25/225	55.6 [2.19]	26.7 [1.05]	26.9 [1.06]	13.0 [.51]	101.6 [4.00]	108.5 [4.27]	92.5 [3.64]	135.1 [5.32]	65.5 [2.58]	45	15	4.57 [.18]	2.54 [.10]

RELEASED FOR PUBLICATION

ALL RIGHTS RESERVED.

THIS DRAWING IS UNPUBLISHED.

© COPYRIGHT - TE Connectivity Ltd.

DIMENSIONS: mm [INCHES]	DWN	31JAN2019	MATERIAL	SEE SHEET 2	FINISH	-
	CHK	31JAN2019	TE Connectivity Ltd.			
TOLERANCES UNLESS OTHERWISE SPECIFIED:	APVD	31JAN2019				
0 PLC ± -	PRODUCT SPEC	-				
1 PLC ± -	APPLICATION SPEC	-				
2 PLC ± -	NAME	TRANSITION, 1 TO 4 CABLES				
3 PLC ± -	SIZE	A4	CAGE CODE	00779	DRAWING NO	C-562A011-25/225-0THRU067-25/225-0
4 PLC ± -	RESTRICTED TO	-				
ANGLES ± -	WEIGHT	-				
CUSTOMER DRAWING			SCALE	DNS	SHEET	1 OF 2
					REV	B

REVISIONS					
P	LTR	DESCRIPTION	DATE	DWN	APVD
	-	SEE SHEET 1	-	-	-

COMPATABILITY CHART				
MATERIAL DASH NO.	MATERIAL DESCRIPTION	RT SPEC	COATING SLASH NO.	COATING S NO.
-25	Elastomer, Fluid Resistant	RW-2070	/42; /86; /225	S1017; S1048; S1206

ORDERING INFORMATION

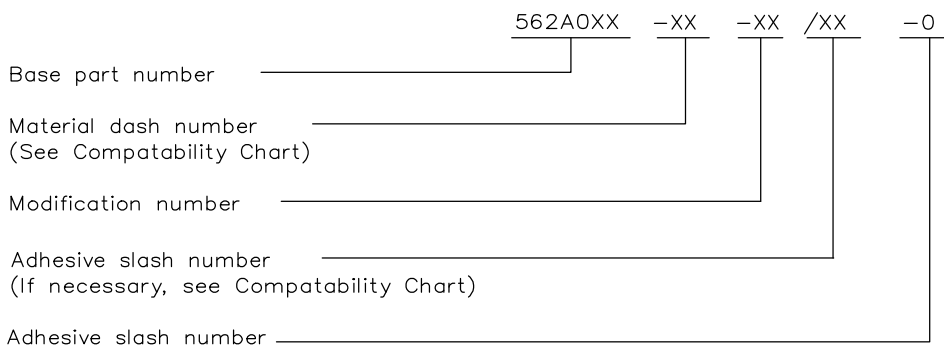



NOTES

- Dimensions appearing in table are as follows:
 - a - As Supplied
 - b - After Unrestricted Recovery
- Coating is optional. As supplied dimensions appearing in table are for uncoated parts. When coating is added, entry diameters will be reduced by 1.5mm[.06] max.
- Molding ports are optional. When -00 modification number is specified molding ports will be located as shown.

RELEASED FOR PUBLICATION

ALL RIGHTS RESERVED.

COPYRIGHT - TE Connectivity Ltd.

DIMENSIONS: mm [INCHES]	DWN PRAVEEN N T	31JAN2019	MATERIAL	-	FINISH	-
	CHK N NAGAR	31JAN2019	 TE Connectivity Ltd.			
TOLERANCES UNLESS OTHERWISE SPECIFIED:	APVD M TAYLOR	31JAN2019				
0 PLC ± -	PRODUCT SPEC	-	NAME	TRANSITION, 1 TO 4 CABLES		
1 PLC ± -	APPLICATION SPEC	-	SIZE	CAGE CODE	DRAWING NO	RESTRICTED TO
2 PLC ± -	WEIGHT	-	A4	00779	 562A011-25/225-0THRU067-25/225-0	-
3 PLC ± -	CUSTOMER DRAWING			SCALE	DNS	SHEET 2 OF 2
4 PLC ± -						REV B
ANGLES ± -						

