

THIS DRAWING IS UNPUBLISHED. RELEASED FOR PUBLICATION  
 © COPYRIGHT BY TYCO ELECTRONICS CORPORATION. ALL RIGHTS RESERVED.

LOC	DIST	REVISIONS					
GA	1	P	LTR	DESCRIPTION	DATE	DWN	APVD
			C	PER LC20-0248-07 / ECO-07-023130	24OCT07	DM	BJ

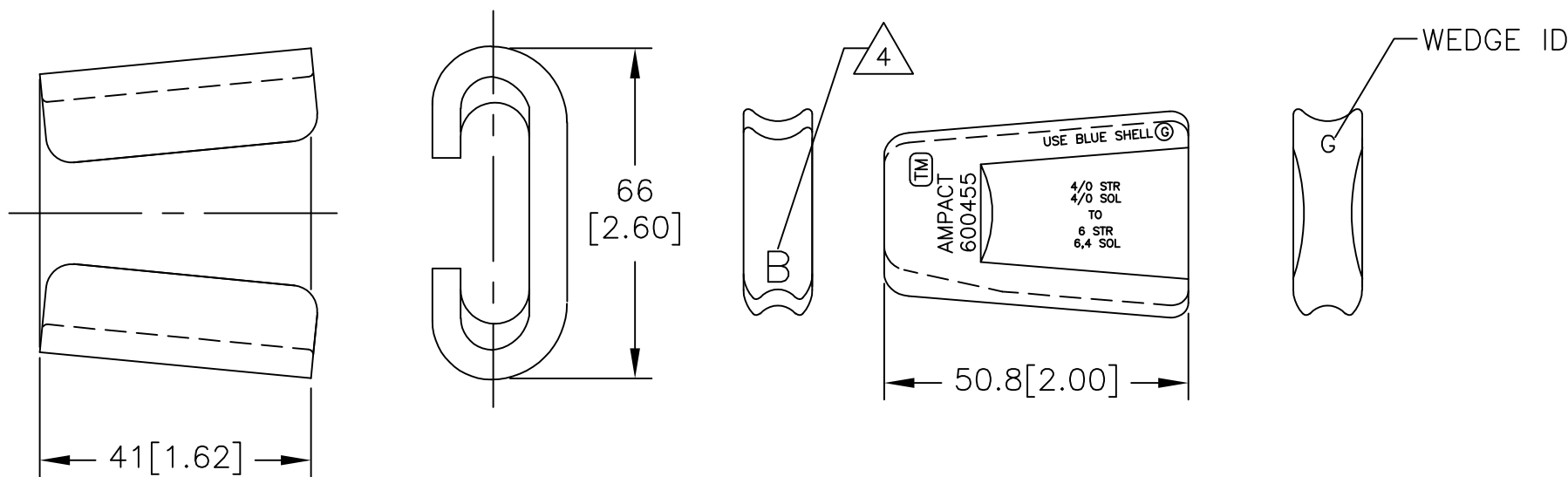

1. DIMENSIONS ARE FOR REFERENCE ONLY.
  2. INHIBITOR IS APPLIED AT FACTORY TO GROOVES OF 'C' BODY AND WEDGE.
  3. FOR CONNECTOR P/N 600455, WIRE SIZES ARE MARKED ON WEDGE. USE BLUE CARTRIDGE P/N 69338-1 AND INSTALL 600455 WITH AMP TOOL P/N 69437.
- △ 4 FOR CONNECTOR P/N: 600455-1, WEDGE IS MARKED WITH LETTER "B" ON FRONT FACE. NO WIRE SIZE, WEDGE ID & P/N ARE SHOWN ON THE WEDGE. 600455-1 IS INSTALLED WITH BATTERY TOOL ONLY.

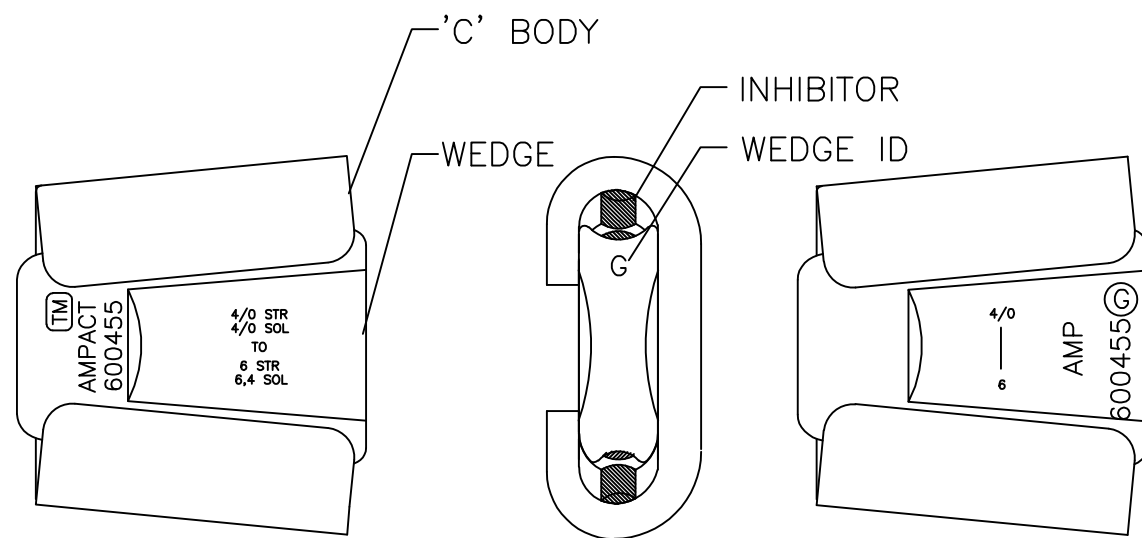

ALTERNATE MARKING ON WEDGE

ALUM. ALLOY	ALUM. ALLOY	600455-1
ALUM. ALLOY	ALUM. ALLOY	600455
WEDGE QTY: 1	'C' BODY QTY: 1	PART NO.

THIS DRAWING IS A CONTROLLED DOCUMENT.		DWN M. SAYMAN 26 JUN 97	Tyco Electronics Corporation Markham, ON L3R-1E1		
DIMENSIONS: MM [INCHES]		CHK G. MENCHELLA 30 JUN 97	NAME CONNECTOR, 4/0-6, MEDIUM SERIES, BLUE CODED, AMPACT		
TOLERANCES UNLESS OTHERWISE SPECIFIED:		APVD P. CHAN 30 JUN 97	PRODUCT SPEC		
0 PLC ±		APPLICATION SPEC			
1 PLC ±		SIZE			
2 PLC ±		CAGE CODE			
3 PLC ±		DRAWING NO			
4 PLC ±		RESTRICTED TO			
ANGLES ±		A3 00779 C-600455			
MATERIAL SEE TABLE		FINISH			
		WEIGHT			
		CUSTOMER DRAWING			
		SCALE NTS			
		SHEET 1 OF 1			
		REV C			