

LOC		DIST		P		F		ZONE		LTR		REVISIONS		DATE	APPD
AF	50											J	REV PER 0710-0427-95	27/SEP/95	PF 05

1. WIRE RANGE: 0.5 - 1.4 mm² [20 - 16 AWG].
2. DIMENSION IN BRACKETS ARE IN INCHES.

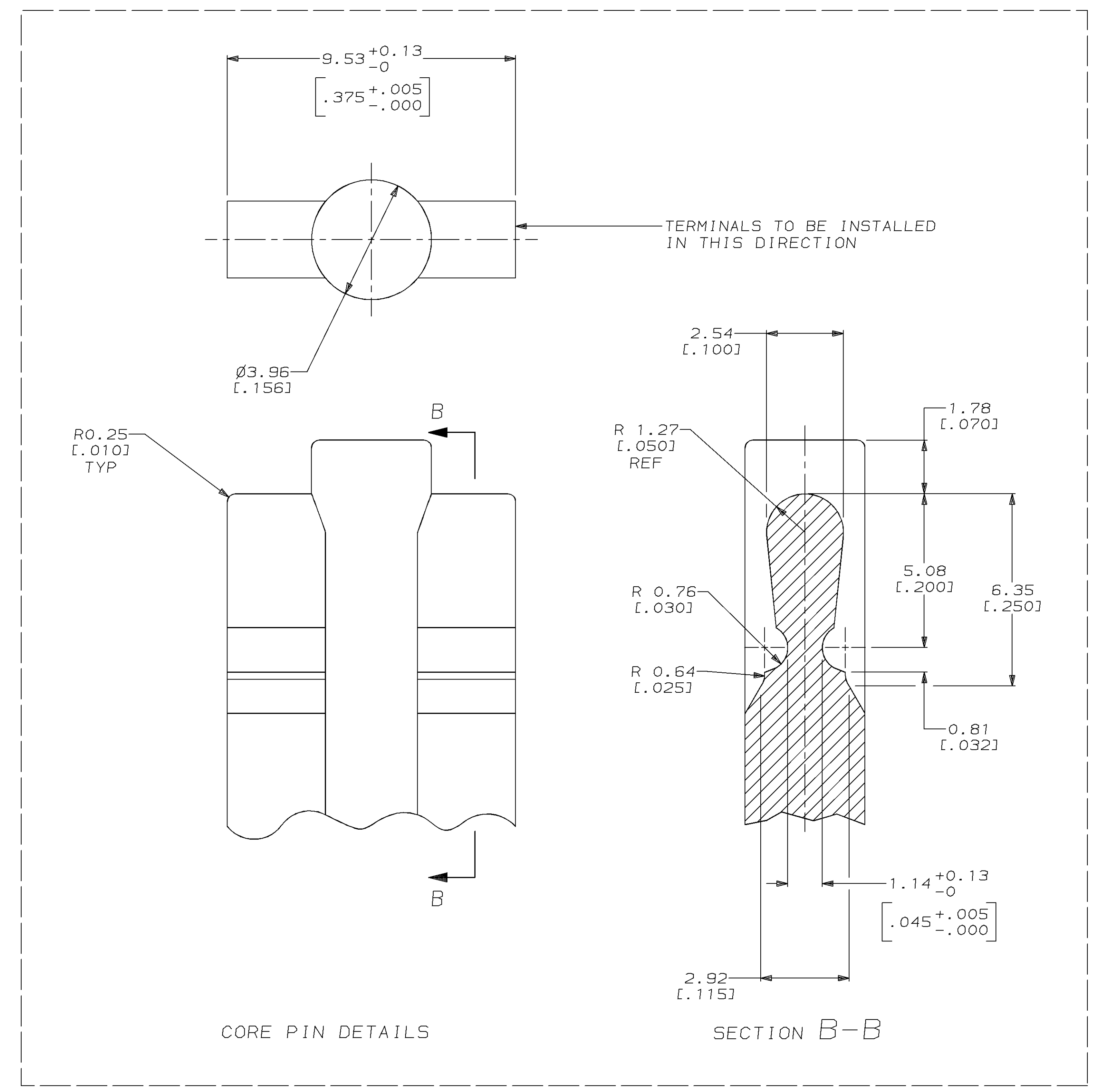
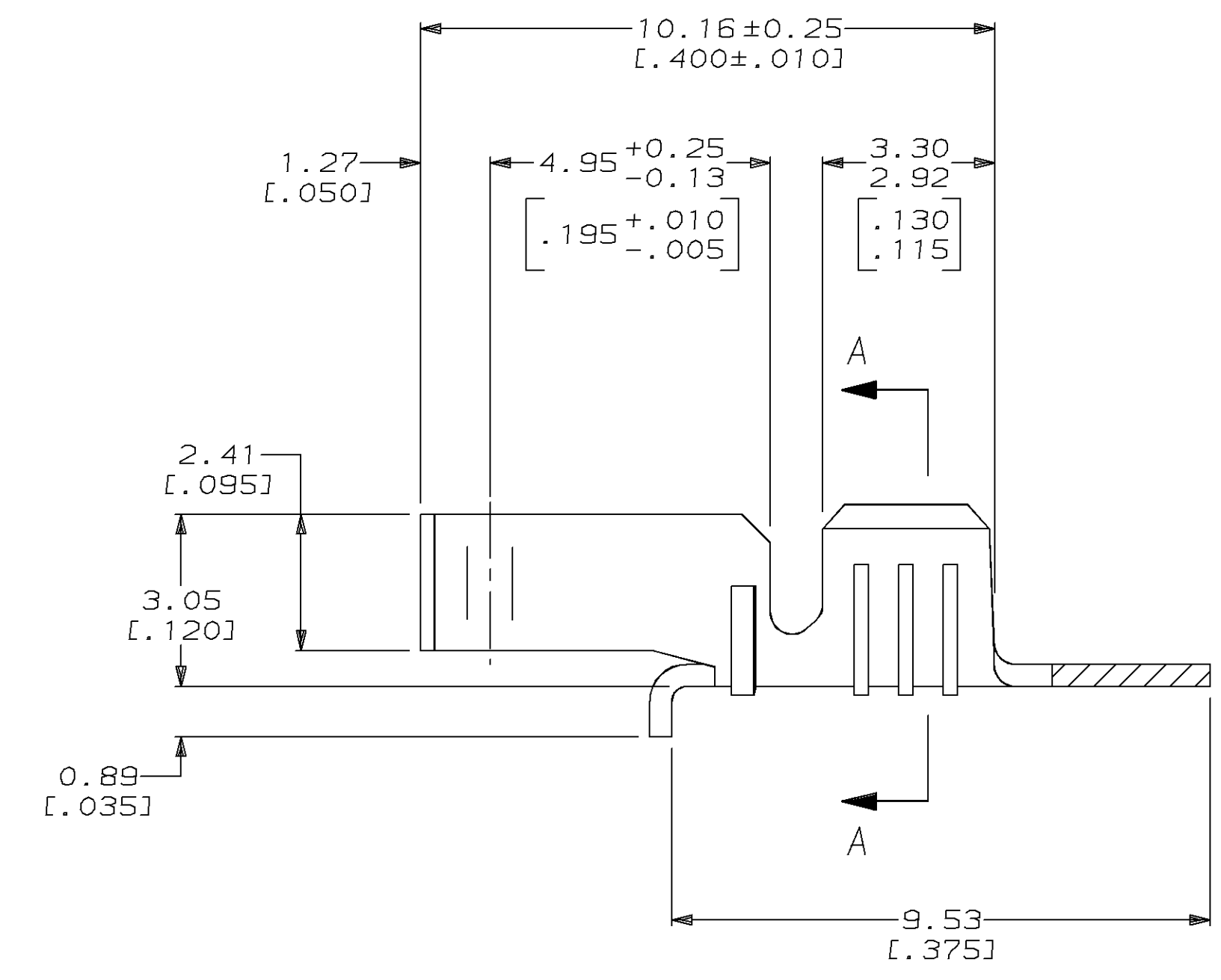
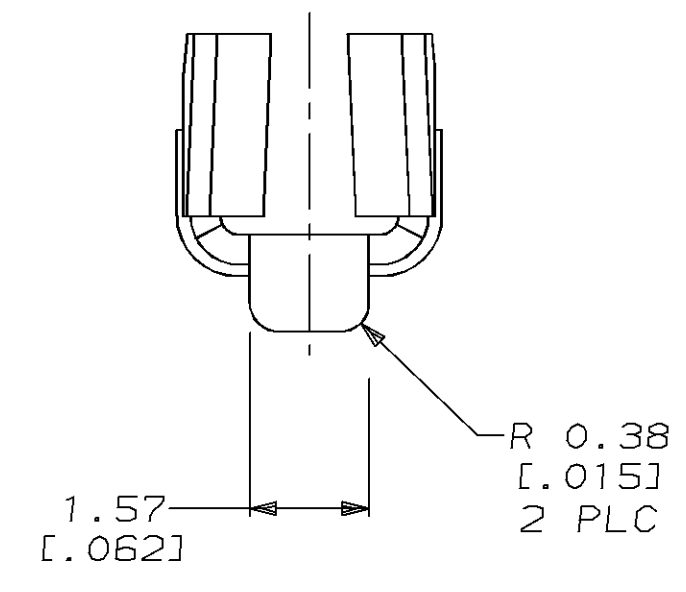
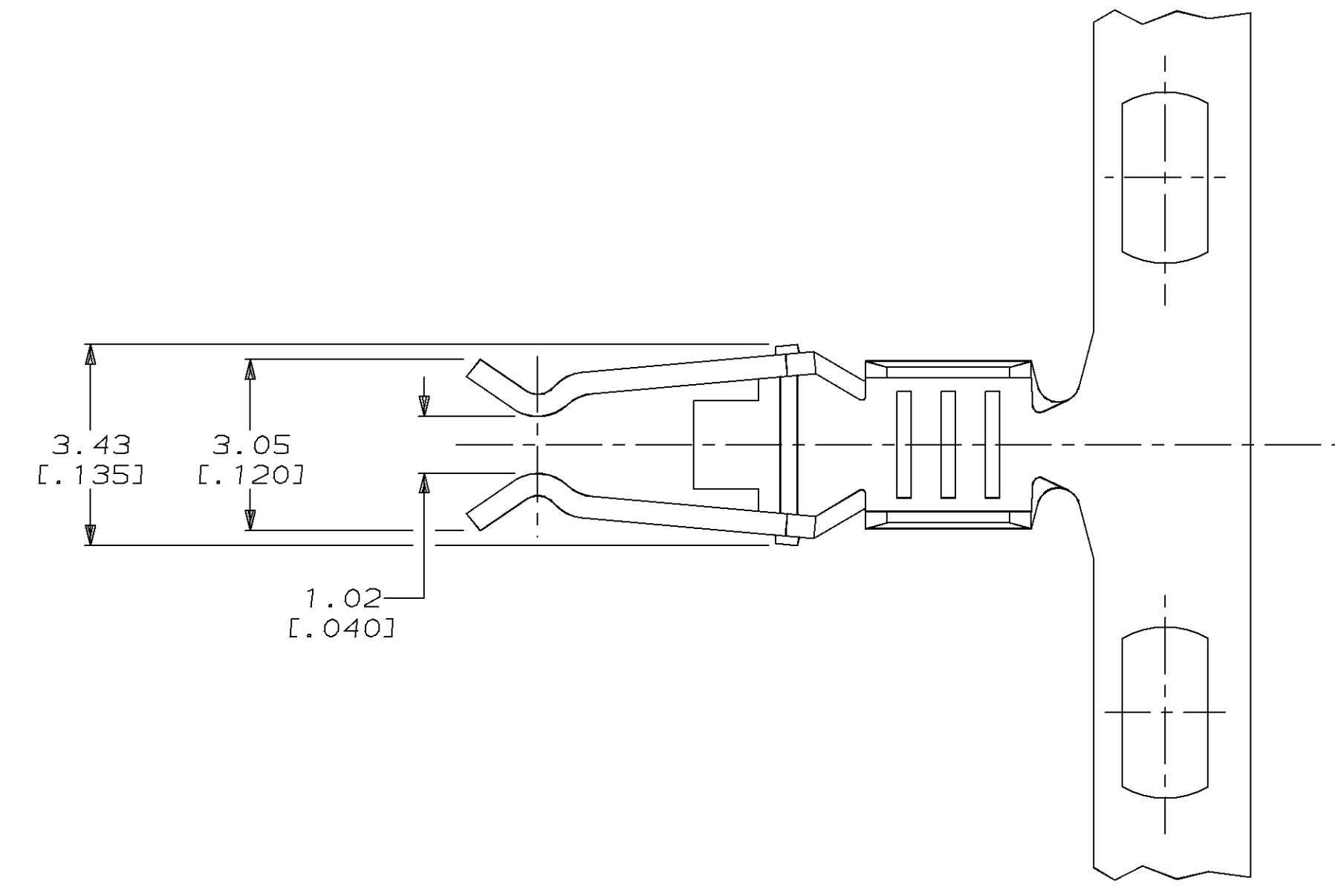
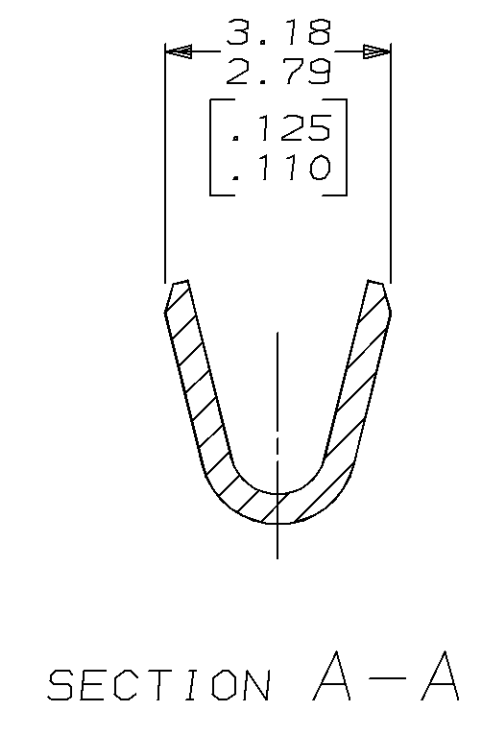

61812-1
PART NO

DO NOT SCALE PRINT. UNLESS SPECIFIED DIMENSIONS IN mm [INCHES] TOLERANCES ON: 2 PLC DEC ± 0.13 [.005] 3 PLC DEC ± - ANGLES ± -	DR 2-18-94 T. BECK	NAME
MATERIAL 0.41 [.016] BRASS	CHK 2-18-94 R. SWING	
FINISH PRE-TIN	APPD 4-03-95 R. GRAY	DRAWING NO C=61812
	APPD 4-03-95 R. GRAY	
	APPLICATION SPEC	SCALE 10:1
	WEIGHT -	SHEET 1 OF 1

AMP AMP Incorporated Harrisburg, PA 17105-3608	
LAMP CLIP	
SIZE D	CAGE CODE 00779
CUSTOMER DRAWING	

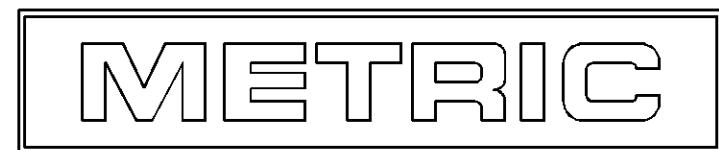

THIS DRAWING IS A CONTROLLED DOCUMENT FOR AMP INCORPORATED. IT IS SUBJECT TO CHANGE AND THE CONTROLLING ENGINEERING ORGANIZATION SHOULD BE CONTACTED FOR THE LATEST REVISION.