

THIS DRAWING IS UNPUBLISHED. RELEASED FOR PUBLICATION .19
 © COPYRIGHT 19 BY AMP INCORPORATED. ALL RIGHTS RESERVED.

| LOC | DIST | REVISIONS | | | |
|-----|------|-------------|----------------------|----------|---------|
| P | LTR | DESCRIPTION | DATE | DWN | APVD |
| CF | 39 | 0 | REL PER NPR | 12-12-96 | VEC RC |
| | | A | REV PER 0G80-0039-00 | 2-4-00 | REH REH |

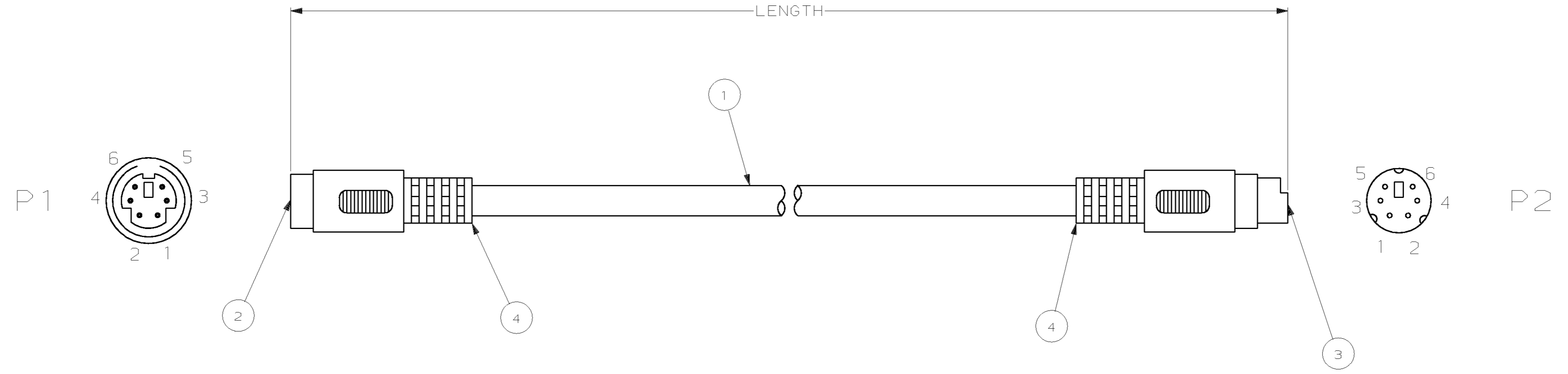

1. PACKAGED IN PRINTED ZIPLOCK POLYBAG.
2. LABEL ON ZIPLOCK POLYBAG TO READ AS FOLLOWS:

| |
|--|
| 621810- 6' PS/2 KEYBOARD EXT. -STRAIGHT |
|--|
3. THIS PRODUCT IS PRODUCED IN COMPLIANCE WITH ANSI/ASQC Z1.4-1993, TO AN INSPECTION LEVEL III, WITH A NORMAL SAMPLING PLAN.

| WIRING SCHEMATIC | | |
|------------------|--|---------|
| P1 POSN | | P2 POSN |
| SHELL | | SHELL |
| 1 | | 1 |
| 2 | | 2 |
| 3 | | 3 |
| 4 | | 4 |
| 5 | | 5 |
| 6 | | 6 |

| PART NUMBER | LENGTH | TOLERANCE | LABEL XX |
|-------------|--------|-------------|----------|
| 621810-1 | 72 | +6.00/-2.00 | 6 |
| 621810-2 | 120 | +6.00/-2.00 | 10 |

OBSOLETE

| OVERMOLD, PVC, BEIGE | 4 |
|-----------------------------------|----------|
| CONNECTOR, 6 PIN MINI DIN, MALE | 3 |
| CONNECTOR, 6 PIN MINI DIN, FEMALE | 2 |
| CABLE, 28 AWG, FOIL/DRAIN | 1 |
| DESCRIPTION | ITEM NO. |

| | | | |
|--|--|------------------------|--|
| THIS DRAWING IS A CONTROLLED DOCUMENT. | | DWN V. COLLER 12-12-96 | AMP AMP Incorporated Harrisburg, PA 17105-3608 |
| DIMENSIONS: INCHES | | CHK D. WILSON 12-12-96 | |
| TOLERANCES UNLESS OTHERWISE SPECIFIED: | | APVD R. CAPP 12-13-96 | NAME |
| 0 PLC ±- | | PRODUCT SPEC | CABLE ASSEMBLY, 6 PIN MINI DIN, M/F |
| 1 PLC ±- | | APPLICATION SPEC | SIZE CAGE CODE DRAWING NO RESTRICTED TO |
| 2 PLC ±- | | WEIGHT | A2 00779 C-621810 |
| 3 PLC ±- | | CUSTOMER DRAWING | SCALE SHEET OF REV |
| 4 PLC ±- | | | NTS 1 OF 1 A |
| ANGLES ±- | | | |
| FINISH | | | |