

THIS DRAWING IS UNPUBLISHED. RELEASED FOR PUBLICATION  
 © COPYRIGHT - By - ALL RIGHTS RESERVED.

LOC		DIST		REVISIONS			
P	LTR	DESCRIPTION		DATE	DWN	APVD	
AF	50	E3		REVISED PER ECR-23-171791	04APR2023	PS CJH	

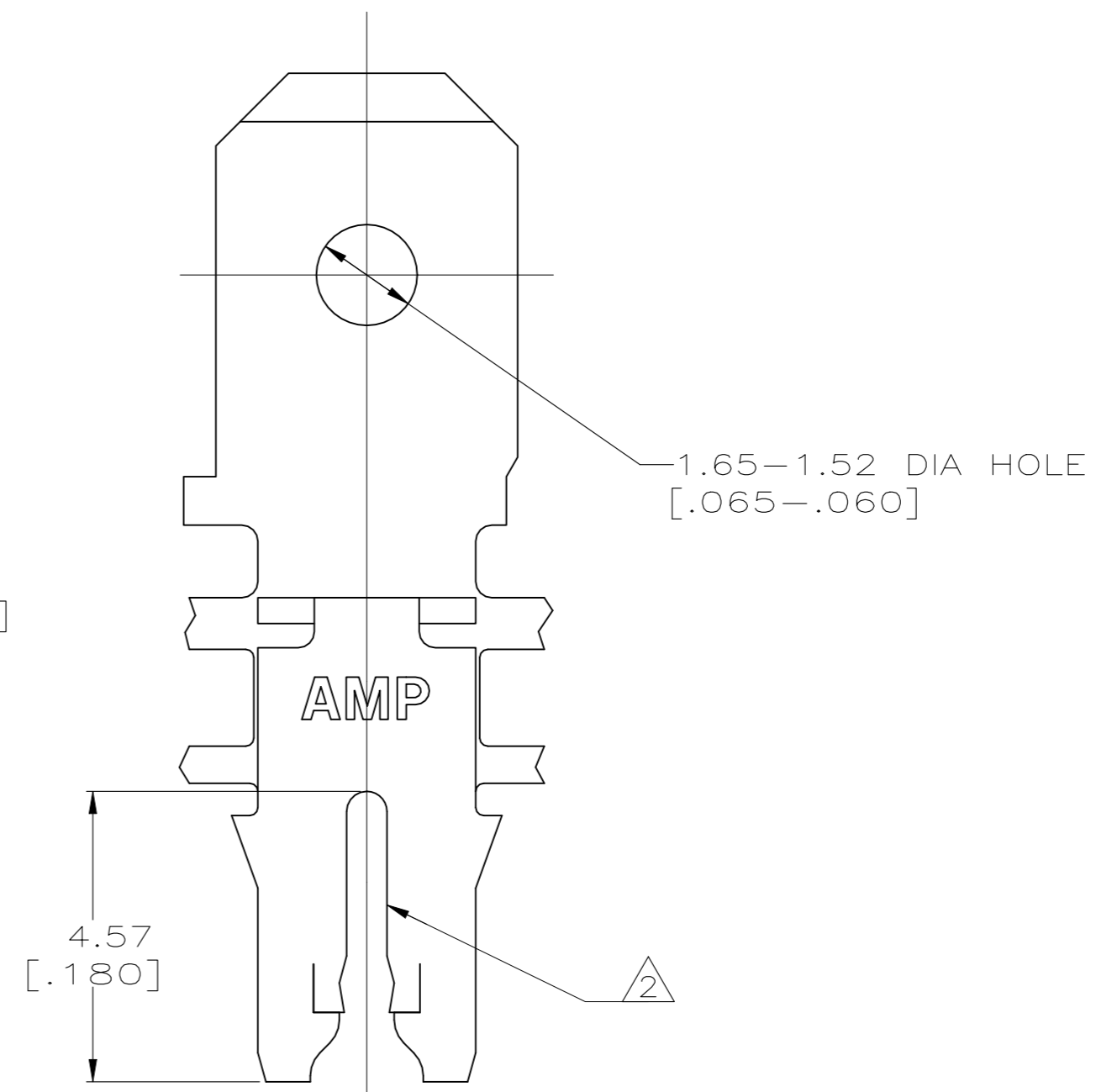
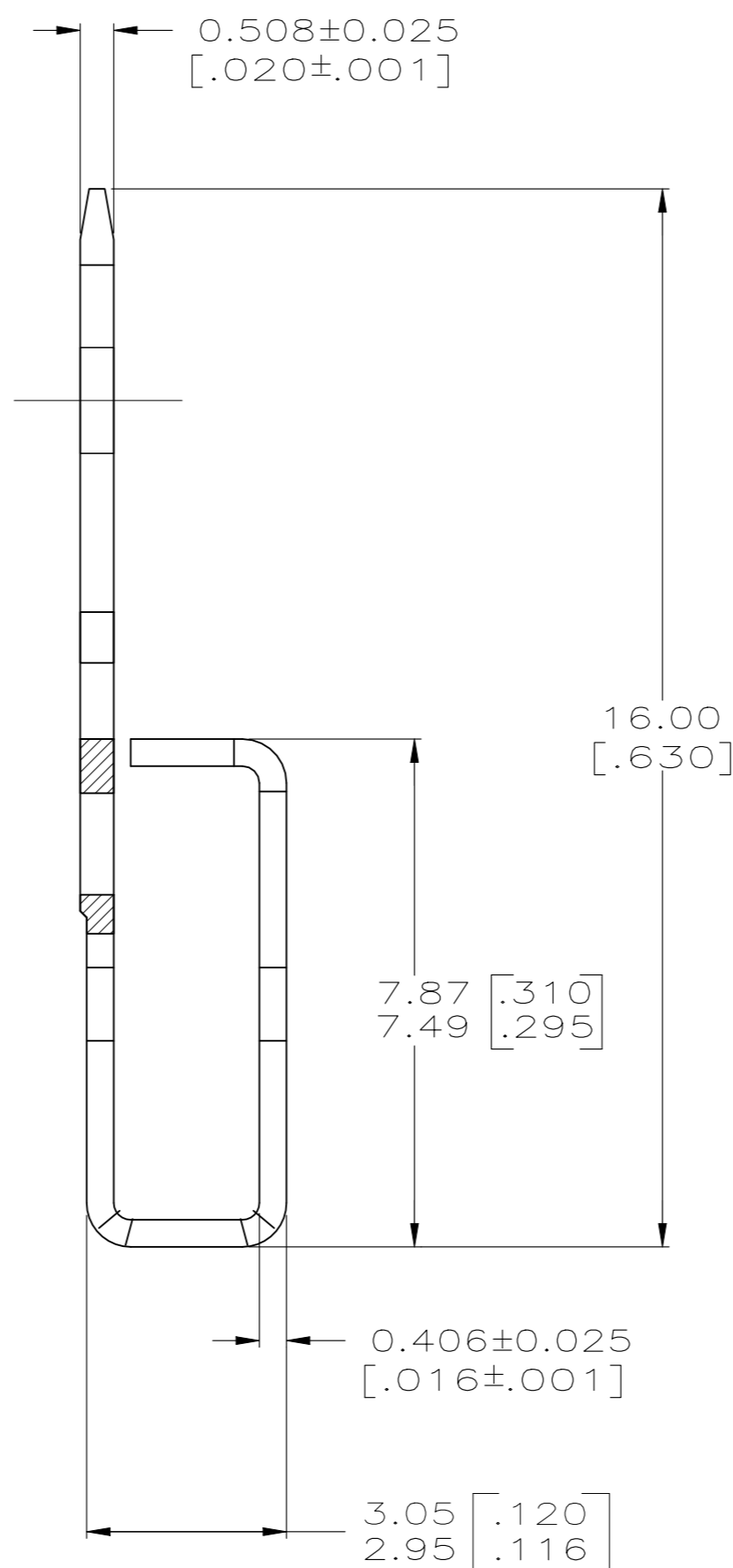
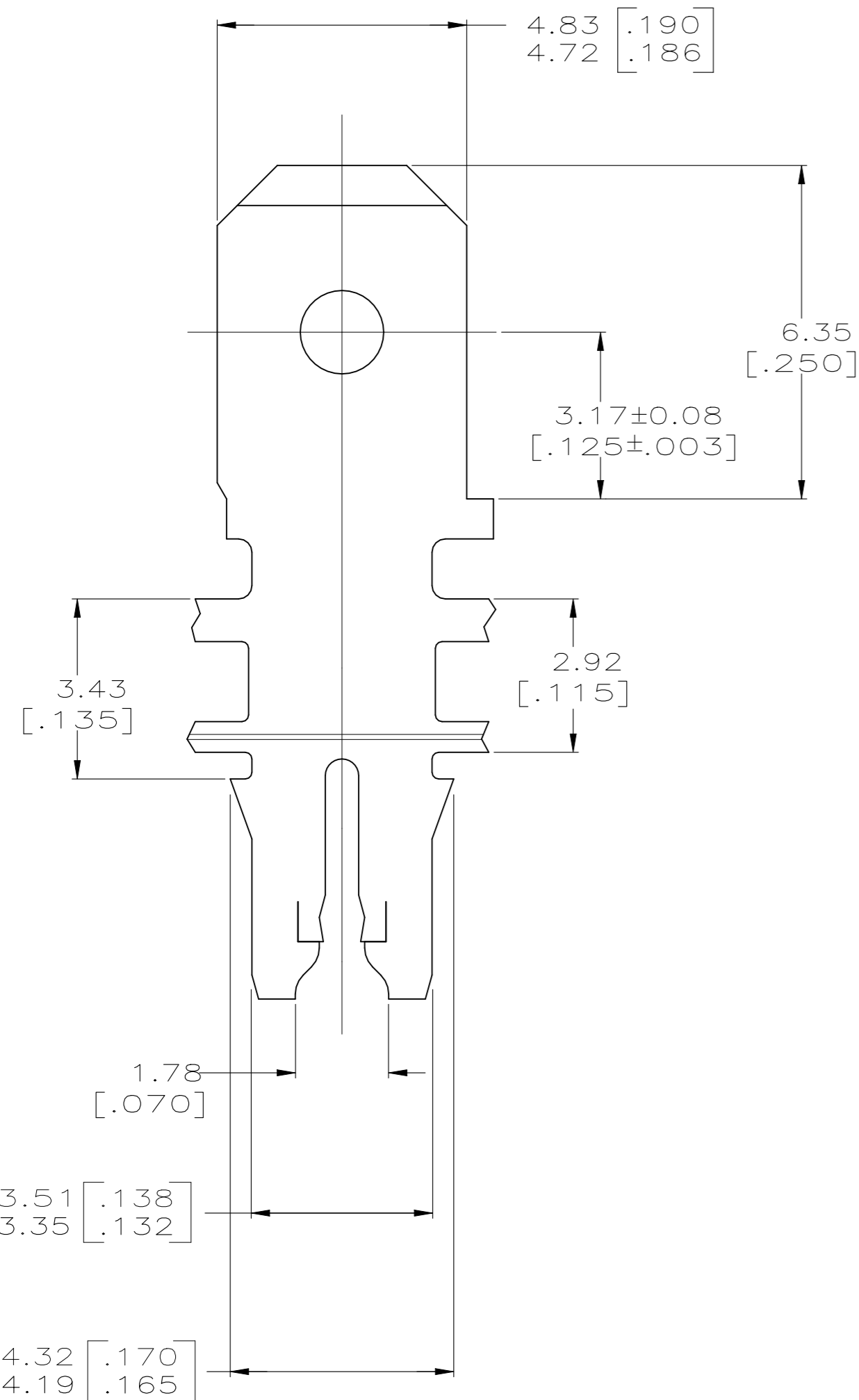
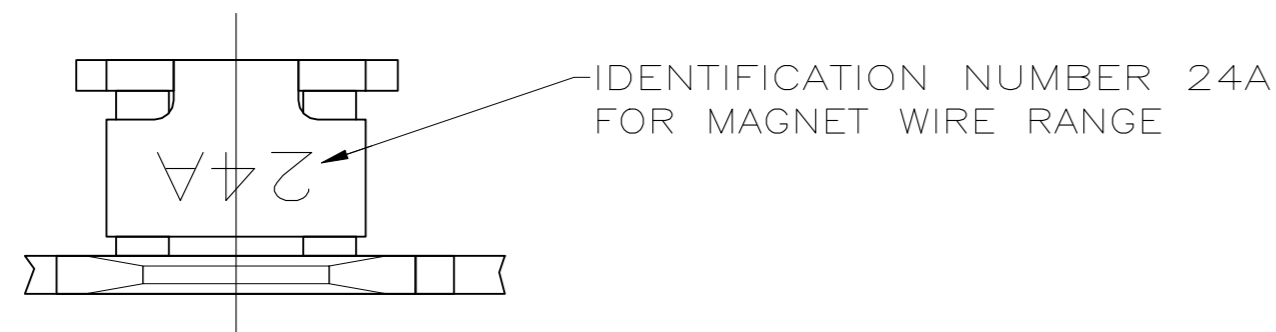

5	REVERSE	TIN PLATE	63668-3
	STANDARD	TIN PLATE	63668-2
5	STANDARD	TIN PLATE	63668-1
	REELING	FINISH	PART NO

THIS DRAWING IS A CONTROLLED DOCUMENT.		DWN MICHAEL S. FEHER 9/3/92	<b>TE</b> TE Connectivity		
DIMENSIONS: MM [ INCHES ]		CHK JEFF R. RUTH 9/4/92			
TOLERANCES UNLESS OTHERWISE SPECIFIED:		APVD TERRY SHUTTER 9/4/92	NAME TERMINAL, TAB, 4.75 [.187] FASTON, MAG-MATE		
0 PLC ± - 1 PLC ± - 2 PLC ± 0.25 [.010] 3 PLC ± - 4 PLC ± - ANGLES ± -		PRODUCT SPEC 108-2012	SIZE A2	CAGE CODE 00779	DRAWING NO C=63668
MATERIAL BRASS	FINISH SEE TABLE	WEIGHT -	SCALE 10:1	SHEET 1 OF 1	RESTRICTED TO -
CUSTOMER DRAWING			REV E3		