

REVISIONS					
P	LTR	DESCRIPTION	DATE	DWN	APVD
B		DIMENSION UPDATED	27-OCT-22	MT	NA

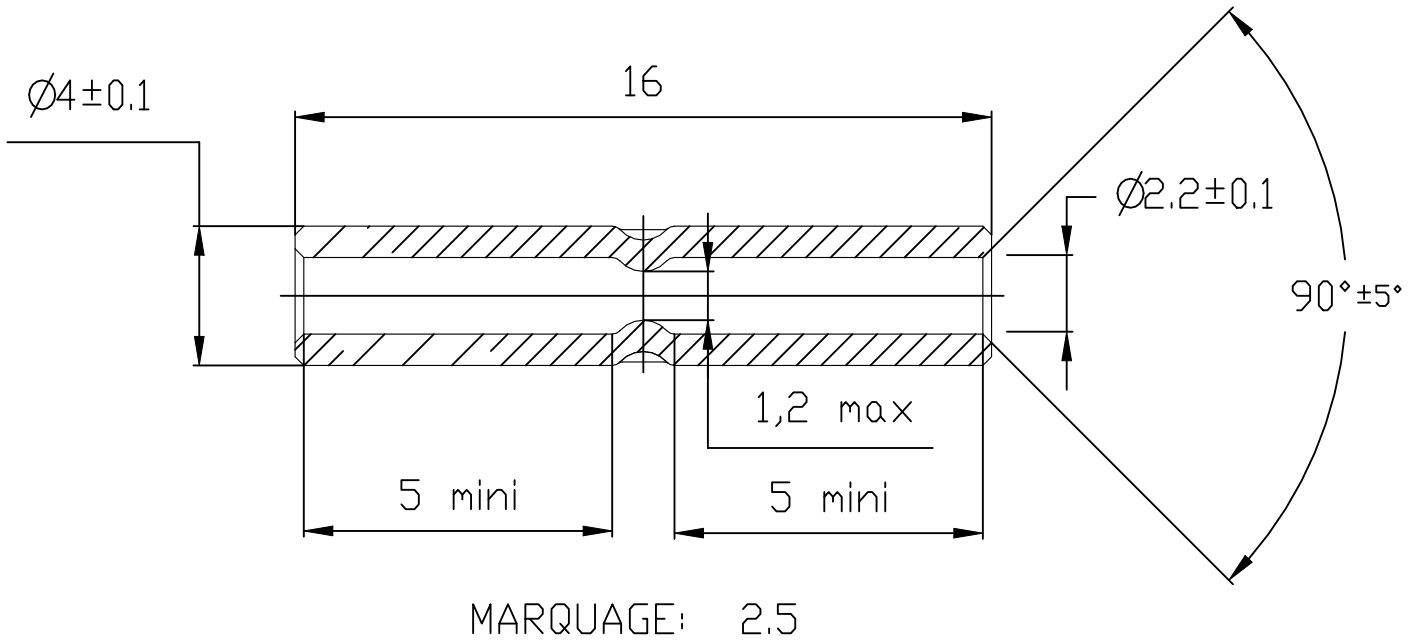

PAR 100	XG7T 2.5	710983-1
QUANTITY	DESCRIPTION	PART NUMBER

TE Connectivity. All Rights Reserved.

19

©

DIMENSIONS: mm	DWN CARLHIAN	16-Mai-06	MATERIAL CUVRE/COPPER	FINISH ETAMA/TINNED				
	CHK F.HEBERT	-	 TE Connectivity					
TOLERANCES UNLESS OTHERWISE SPECIFIED:	APVD N. ALMEDIA	-			NAME XG7T 2.5			
	0 PLC ± -	PRODUCT SPEC -	SIZE A4	CAGE CODE 00779	DRAWING NO 710983	RESTRICTED TO -		
1 PLC ± -	APPLICATION SPEC NF C 20-130	WEIGHT 1.23g	CUSTOMER DRAWING			SCALE 3:1	SHEET 1 OF 1	REV B
2 PLC ± -								
3 PLC ± -								
4 PLC ± -								
ANGLES ± -								