

THIS SPECIFICATION SHEET FORMS A PART OF THE LATEST ISSUE OF RAYCHEM SPECIFICATION 1200.

**CONSTRUCTION DETAILS**

DIMENSIONS ARE NOMINAL VALUES IN INCHES UNLESS OTHERWISE DESIGNATED.

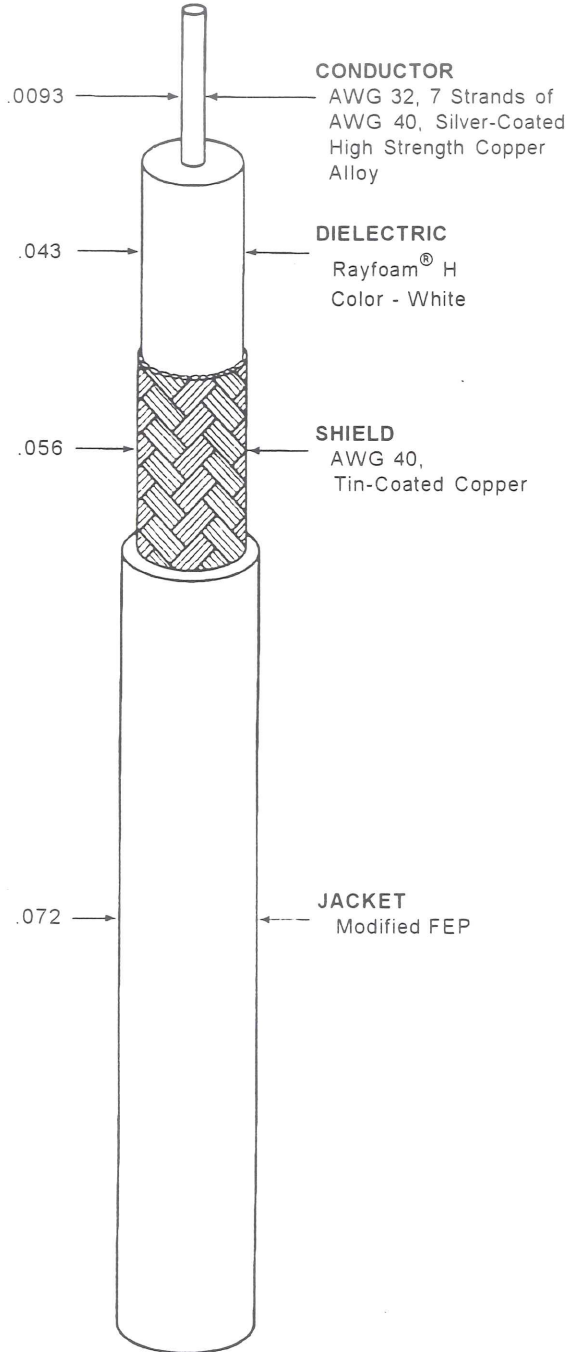

**ELECTRICAL CHARACTERISTICS**

CHARACTERISTIC IMPEDANCE	75 ± 5 ohms, Method B
CAPACITANCE	17.7 pF/ft. (nominal) at 1 kHz
VELOCITY OF PROPAGATION	76% (nominal)

**ADDITIONAL REQUIREMENTS**

ELECTRICAL

CONDUCTOR RESISTANCE	198.ohms/1000 ft. (nominal)
INSULATION RESISTANCE	10,000 megohms (minimum) for 1000 ft.
JACKET FLAWS	
SPARK TEST	1.0 kV (rms), 60 Hz
IMPULSE TEST	6.0 kV (peak)
VOLTAGE WITHSTAND (DIELECTRIC)	1000 volts (rms) (minimum)

ENVIRONMENTAL

AGING STABILITY	135°C/-55°C/2.00 inch mandrel
FLAMMABILITY	Method B
HEAT SHOCK	225°C
LOW TEMPERATURE-COLD BEND	-55°C/2.00 inch mandrel
VOLTAGE WITHSTAND (POST ENVIRONMENTAL)	1000 volts (rms), 1 minute

PHYSICAL

INSULATION (DIELECTRIC)	
ELONGATION	50% (minimum)
TENSILE STRENGTH	600 lbf/in <sup>2</sup> (minimum)
JACKET	
ELONGATION	200% (minimum)
TENSILE STRENGTH	2000 lbf/in <sup>2</sup> (minimum)
JACKET THICKNESS	.008 inch (nominal)
SHIELD COVERAGE	90% (minimum)
	25 ± 5° Braid Angle

WEIGHT	4.8 lbs/1000 ft. (nominal)
--------	----------------------------

Outer jacket color will be transparent white (designated by a "9X" appended to the part number, e.g. 7532D1024-9X) unless otherwise specified.

Designate outer jacket color with a dash number in accordance with MIL-STD-681.