

REVISIONS				
REV	DESCRIPTION	DATE	BY	APP'D
E2	REVISED PER ECR-24-196907	17JUL2024	MV	JP

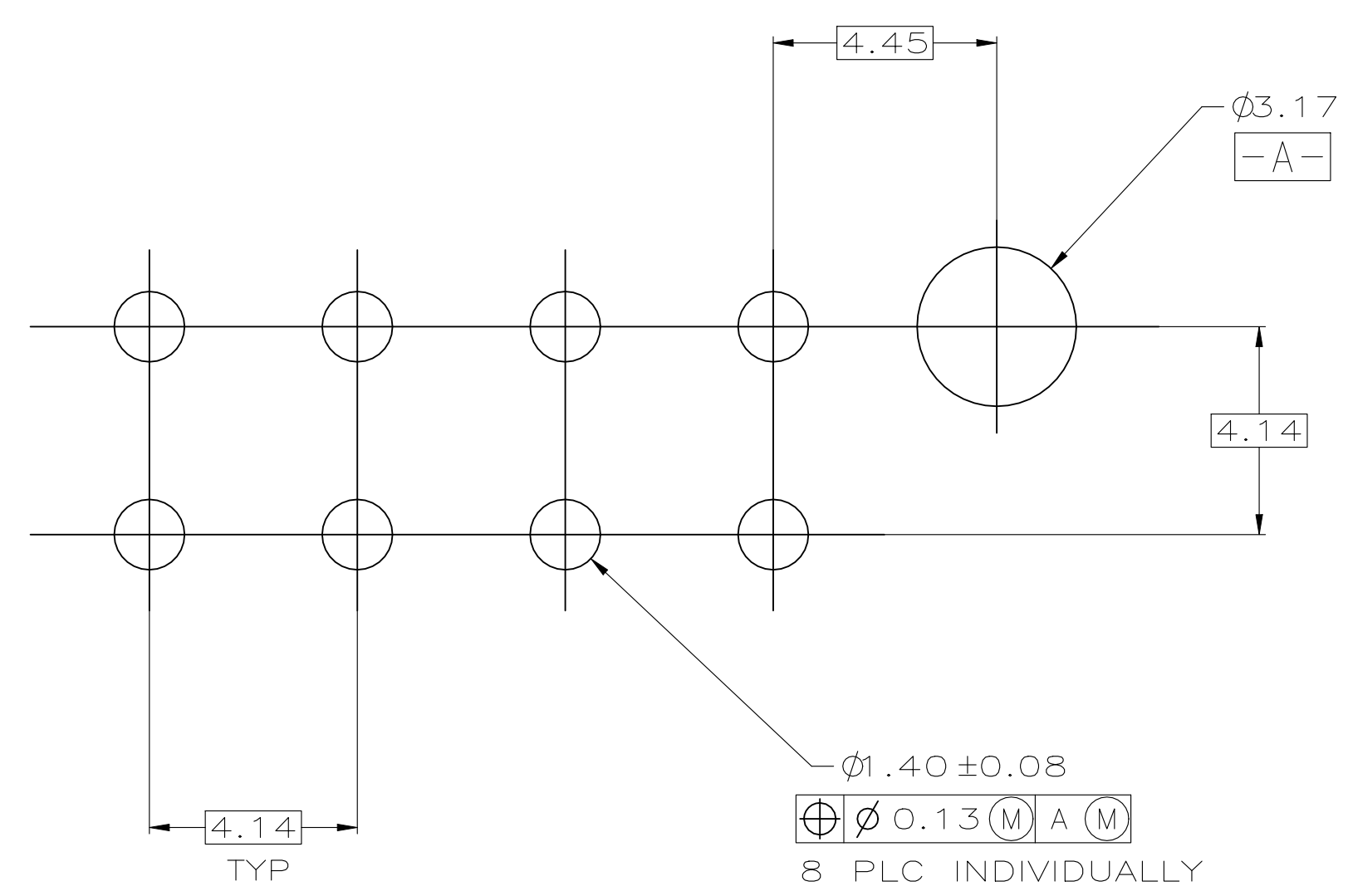
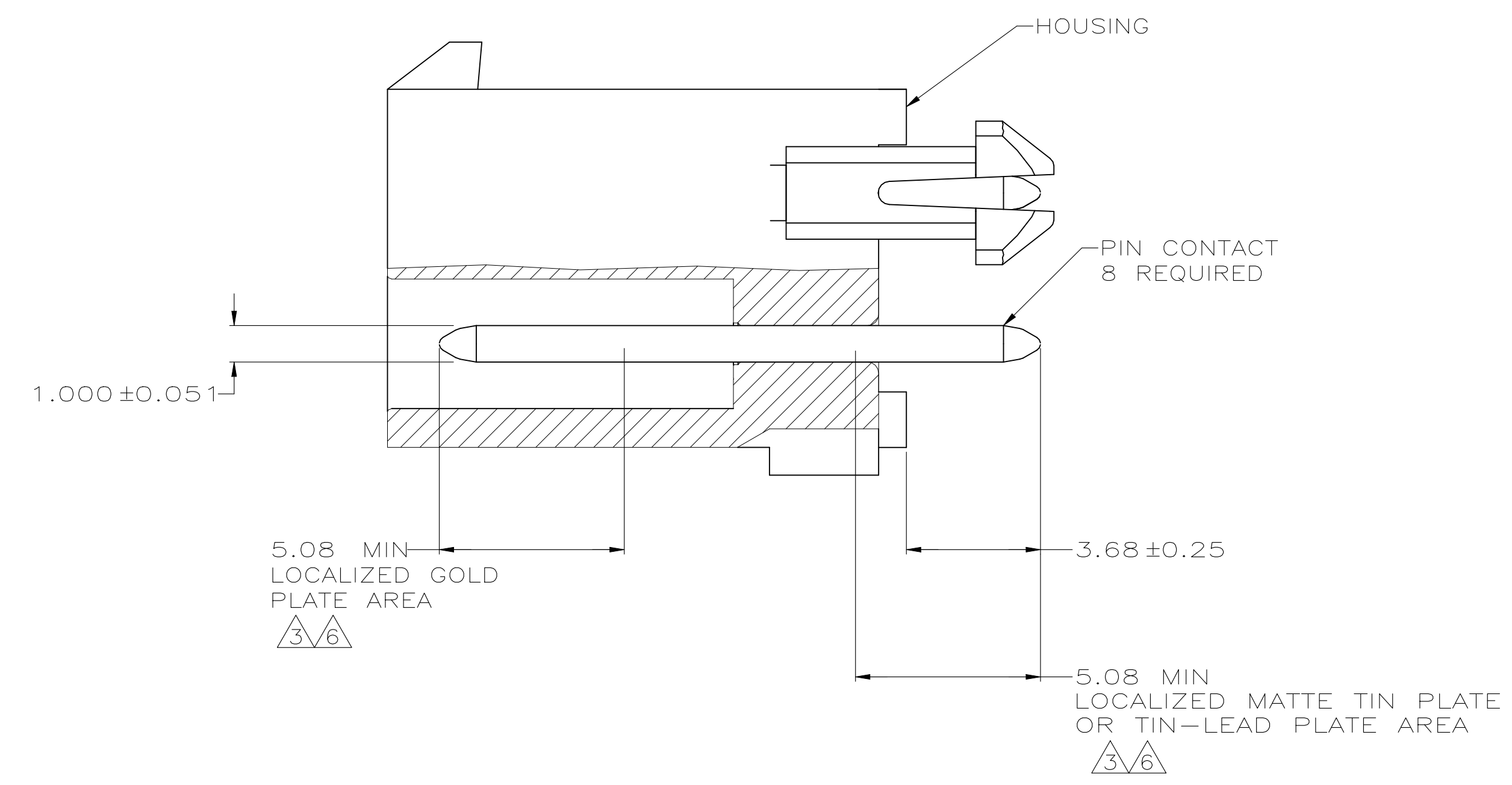
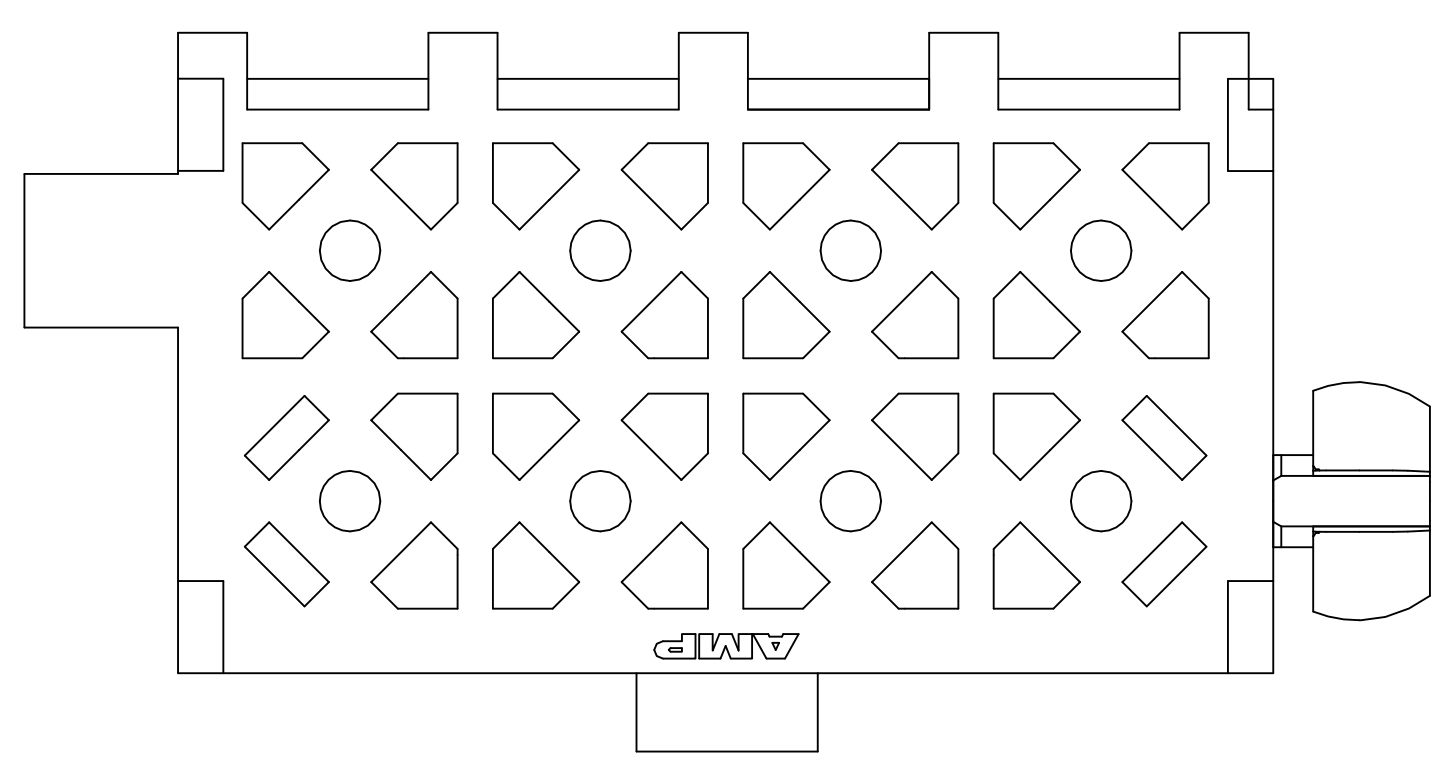
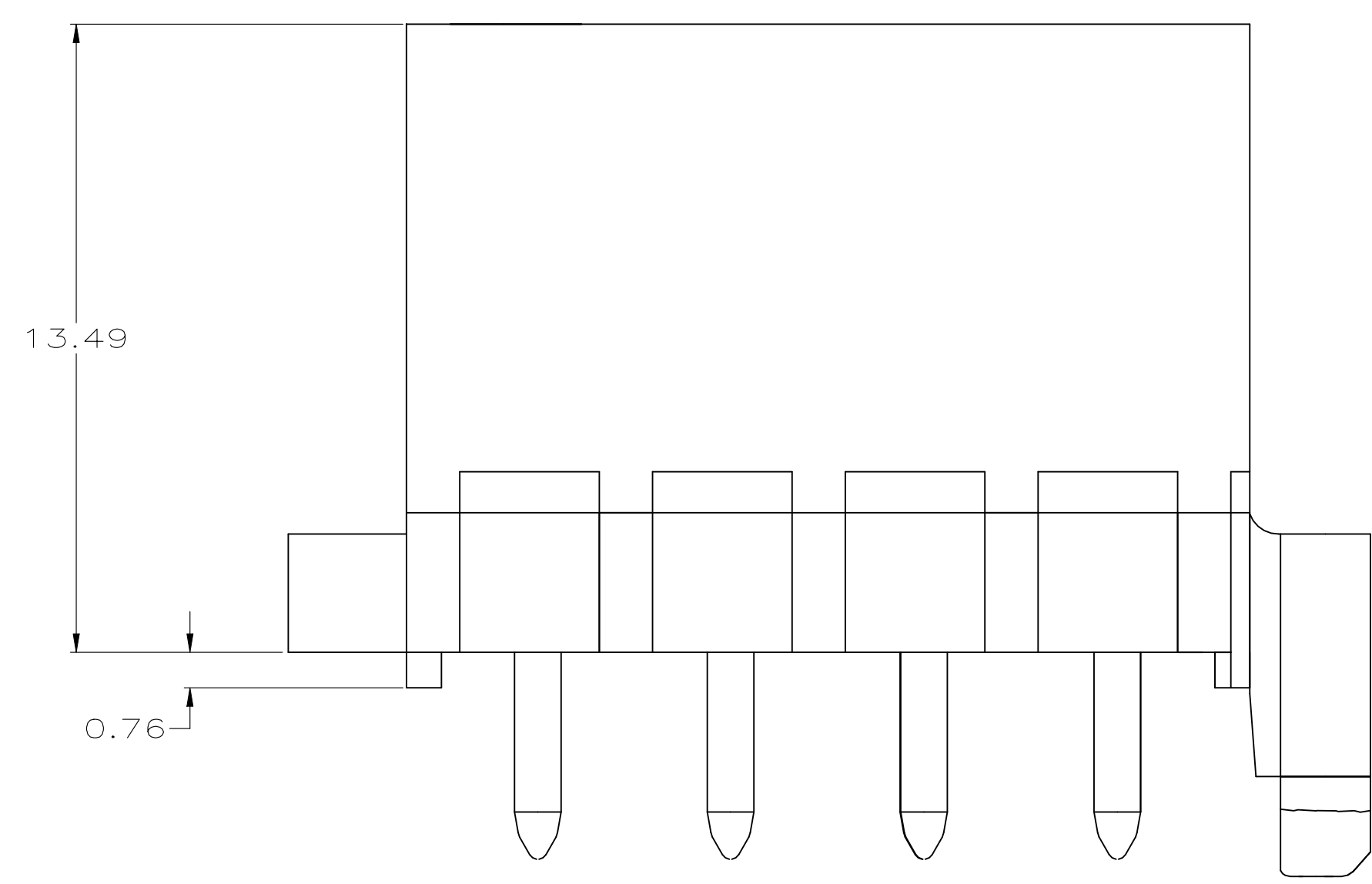
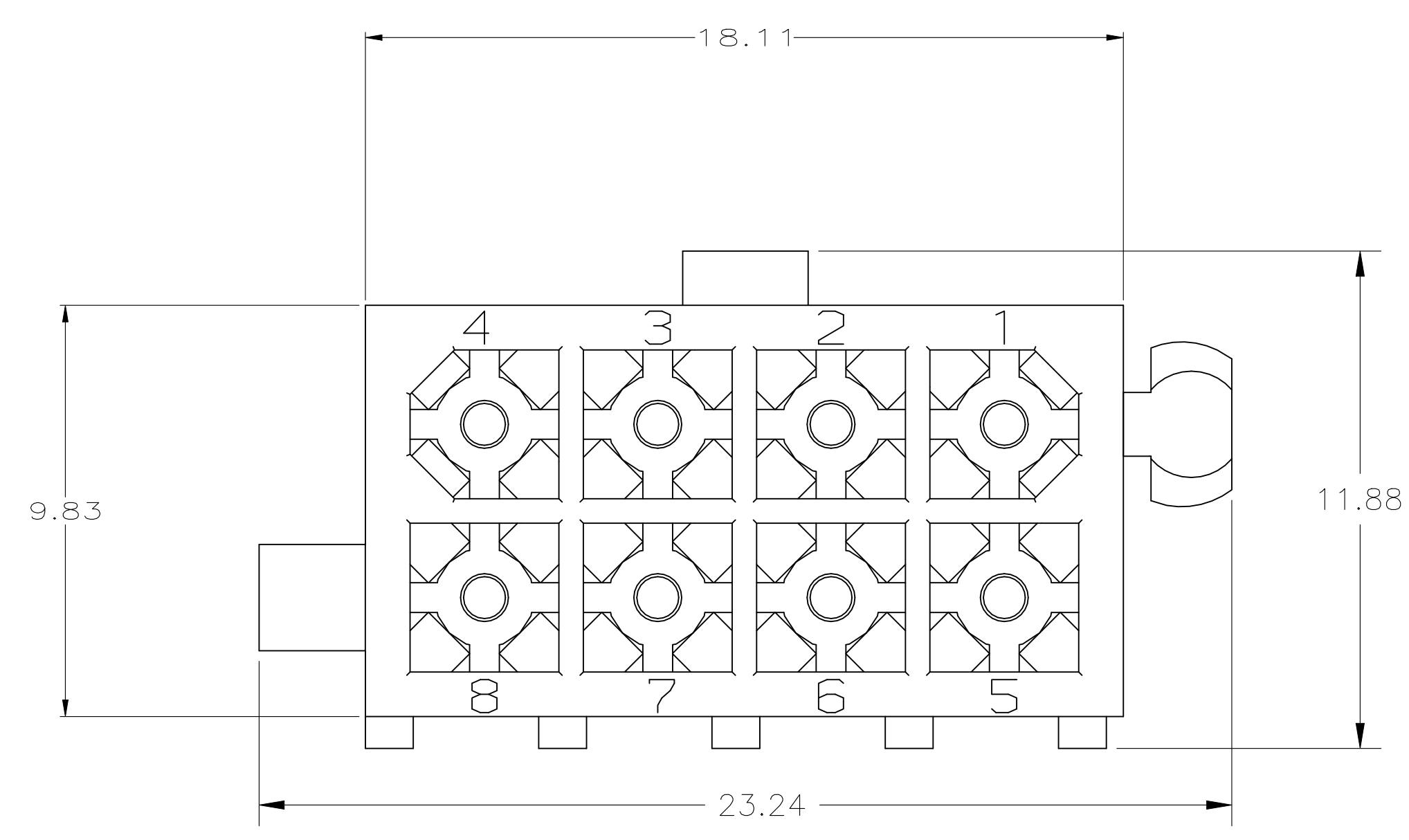

RECOMMENDED MOUNTING HOLE PATTERN FOR 1.57 THICK P.C. BOARD

SUPERSEDE WITH 1-794065-1
 SUPERSEDE WITH 1-794065-0

MATERIAL	FINISH	MATERIAL	COLOR	PART NO.
BRASS, TIN	4	HIGH TEMP NYLON, UL94V-2	BLACK	6-794065-0
BRASS, TIN	4	HIGH TEMP NYLON, UL94V-0	BLACK	5-794065-0
BRASS, GOLD	5	NYLON, UL94V-0	WHITE	1-794065-1
BRASS, TIN	4	NYLON, UL94V-0	WHITE	1-794065-0
BRASS, GOLD	3	NYLON, UL94V-0	WHITE	794065-2
BRASS, TIN-LEAD	2	NYLON, UL94V-0	WHITE	794065-1

- PINS TO COMPLY WITH AMP SOLDERABILITY SPEC. 109-11-3.
- 0.00381 MIN MATTE TIN LEAD PLATE OVER 0.00127 MIN NICKEL.
- 0.00076 MIN GOLD PLATE IN THE LOCALIZED PLATE AREA, 0.00381 MATTE TIN LEAD IN THE LOCALIZED PLATE AREA, BOTH OVER 0.00127 MIN NICKEL.
- 0.00381 MIN MATTE TIN PLATE OVER 0.00127 MIN NICKEL.
- 0.00076 MIN GOLD PLATE IN THE LOCALIZED PLATE AREA, 0.00381 MATTE TIN IN THE LOCALIZED PLATE AREA, BOTH OVER 0.00127 MIN NICKEL.

THIS DRAWING IS A CONTROLLED DOCUMENT.

DIMENSIONS: mm	TOLERANCES UNLESS OTHERWISE SPECIFIED:	0 PLC ± -	1 PLC ± -	2 PLC ± 0.13	3 PLC ± -	4 PLC ± -	ANGLES ± -
MATERIAL	FINISH	WEIGHT	SIZE	CAGE CODE	DRAWING NO	RESTRICTED TO	
			A1	00779	794065		

CUSTOMER DRAWING SCALE 8:1 SHEET 1 of 1 REV E2