

OLD STOCK NO.	
OLD DRAWING NO.	

PARTS LIST			
ITEM NO.	ARTICLE NO.	DESCRIPTION	QTY. REQD.

**MAIN VIEWS SHOW SENSOR & GROMMET AS INSTALLED.  
SEE FITTING INSTRUCTIONS FOR DELIVERED CONDITION**

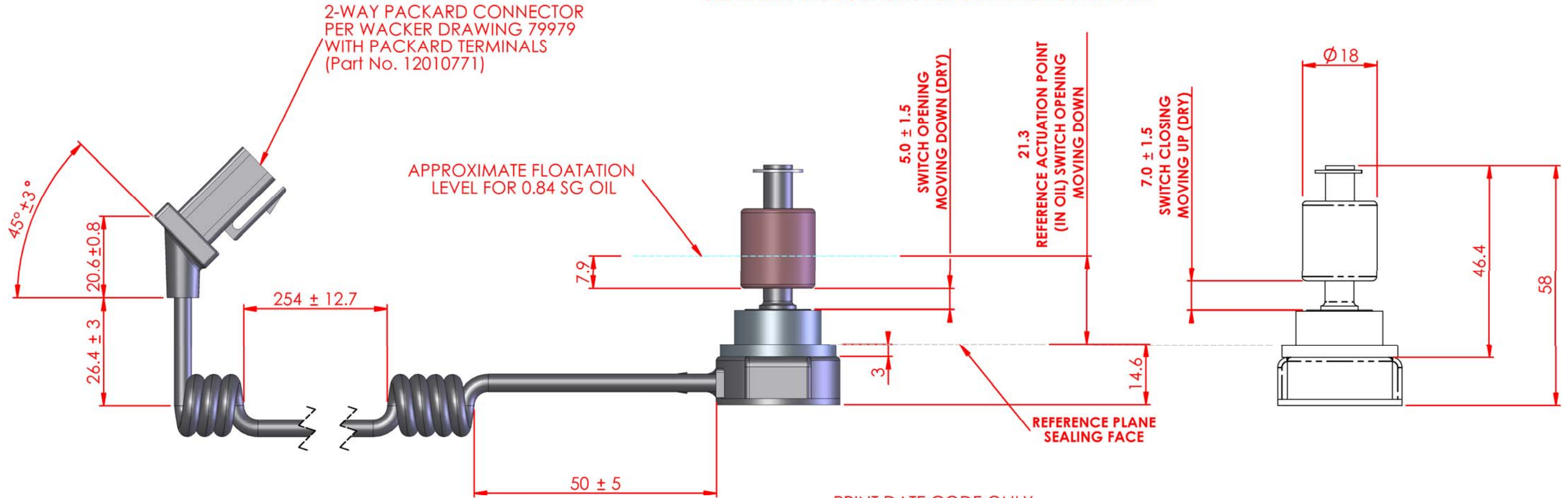

**MATERIAL SPECIFICATION**

CABLE: 2 CONDUCTORS #22 AWG (26/36 TIN SOFT COPPER WITH PVC INSULATION) BLACK GLOSS POLYURETHANE JACKET Ø 4.3 nom.

SENSOR & LID: NYLON 6/6

FLOAT: NBR RUBBER

GROMMET: NITRILE, 55 SHORE HARDNESS ±5

CIRCLIP: STAINLESS STEEL

SWITCH: COTO RI46

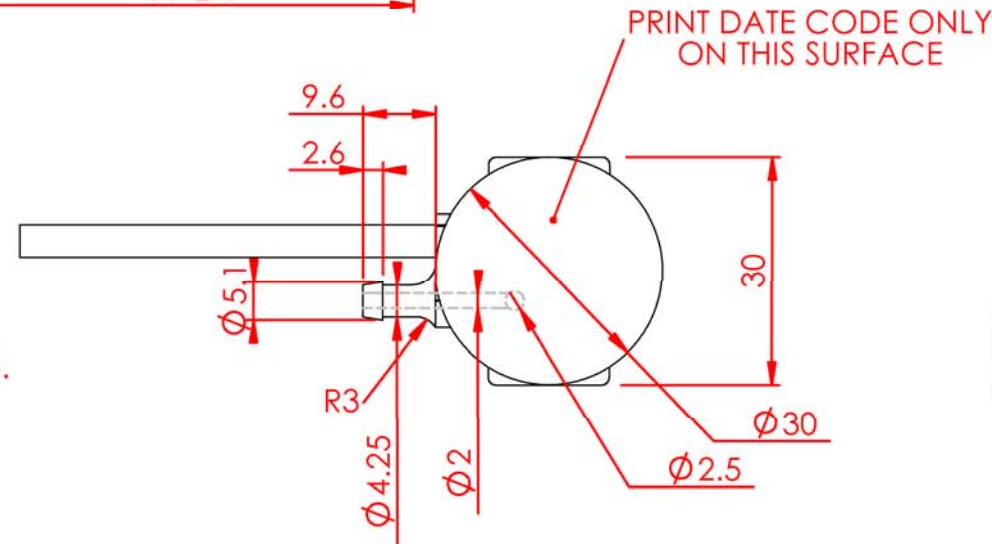

FILTER UNIT MOUNTING HOLE DIMENSIONS:  
Ø 19.40 ± 0.1 by 4.80 ± 0.1 thickness

**FITTING INSTRUCTIONS**

- 1) SENSOR IS SUPPLIED WITH GROMMET LOOSE FROM FITTING. (SEE SKETCH BELOW)
- 2) PUSH GROMMET INTO MOUNTING HOLE ON FILTER UNIT.
- 3) APPLY LUBRICANT TO PUSH-FIT FEATURE OF SENSOR.
- 4) PRESS SENSOR HOME INTO GROMMET.

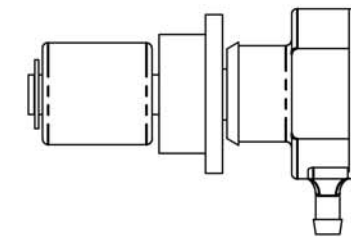

REFERENCE DRAWINGS: WACKER PART / DRAWING NUMBER 160663  
GTI DEVELOPMENT DRG P0901-07 revB

REVISION	<b>A</b>						
CHANGE ORDER NO.	-						
DATE	-						
APPROVED	-						
THIS DRAWING IS THE PROPERTY OF GENTECH International Limited AND SHOULD NOT BE COPIED OR USED FOR MANUFACTURE OR OTHERWISE DISCLOSED WITHOUT THE PRIOR WRITTEN CONSENT OF THE COMPANY ©		MATERIAL <b>SEE NOTES</b>					
		FINISH <b>BLACK</b>					

UNLESS OTHERWISE SPECIFIED DIMENSIONS ARE IN MILLIMETRES TOLERANCES ARE : MARKED ON DIMENSIONS	CAD GENERATED DRAWING DO NOT MANUALLY DUPLICATE	GENTECH INTERNATIONAL LIMITED GIRVAN, Ayrshire, U.K.	
DRAWN	FM 02/04/04	PART NAME	
CHECKED	KJM 02/04/04	<b>VS-X0901C OIL LEVEL SENSOR</b>	
APPROVED	IH 02/04/04	SIZE A3	ARTICLE NO. <b>81539-000</b>
DO NOT SCALE DRAWING		SCALE 1:2	REV. <b>A</b>
		SHEET 1	OF 1