

REVISIONS

P	LTR	DESCRIPTION	DATE	DWN	APVD
	A	INITIAL REL PER LC20-0052-21	13MAY2021	RS	JO

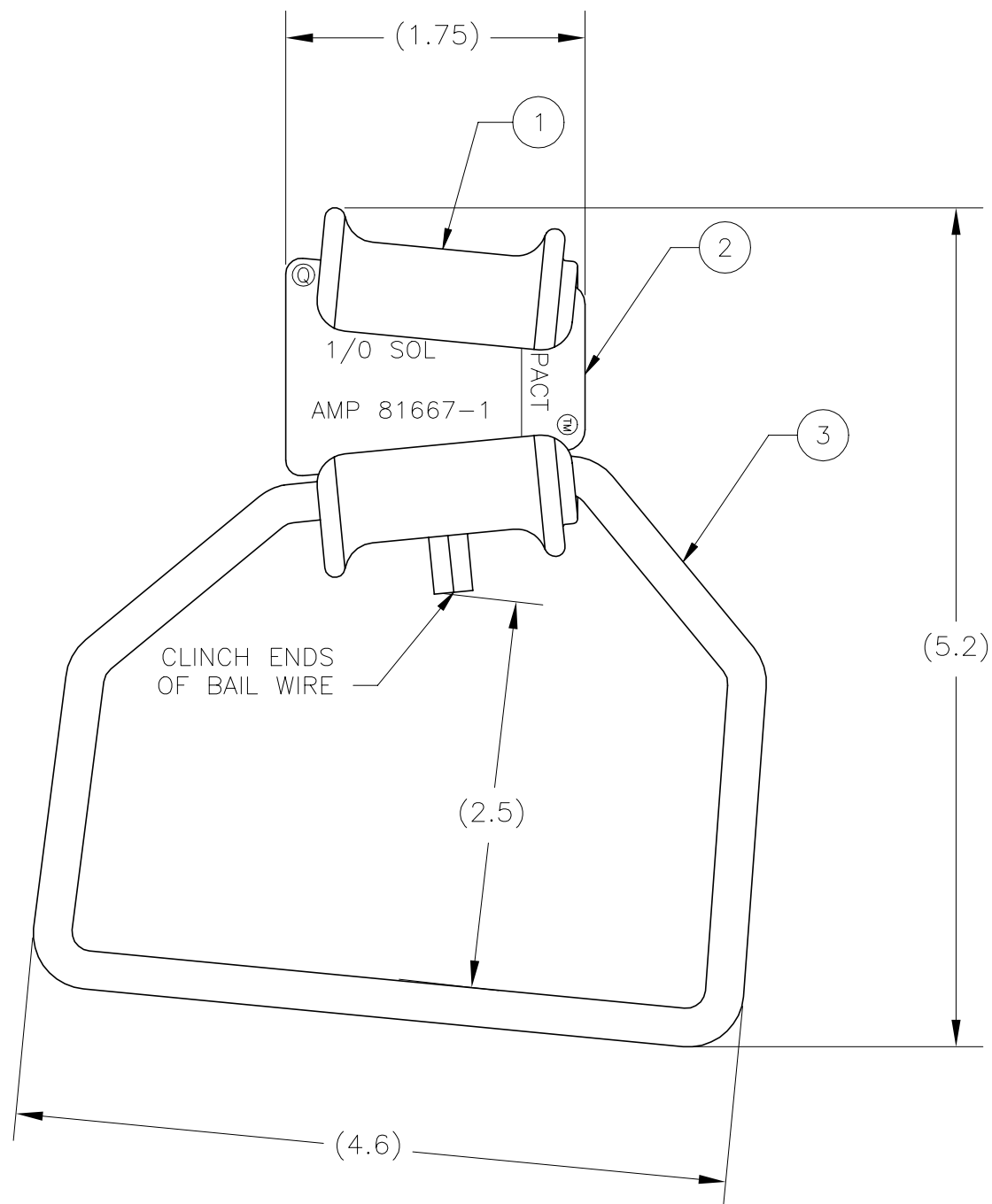

1. DIMENSIONS ARE FOR REFERENCE ONLY.
2. INHIBITOR IS APPLIED AT FACTORY TO GROOVES OF 'C' BODY AND WEDGE.
3. WIRE SIZES ARE MARKED ON WEDGE
4. USE WHITE SHELL PART NO. 69338-5.

#2	1/0, 1, 2 STR 1/0, SOL	81667-1
BAIL SIZE	RUN CONDUCTOR RANGE	PART NO.

1	BAIL, COPPER, TIN PLATED	3
1	WEDGE, ALUM ALLOY	2
1	C BODY, ALUM ALLOY	1
QTY	DESCRIPTION	ITEM NO
PARTS LIST		

THIS DRAWING IS A CONTROLLED DOCUMENT.		DWN RAVI.S 13MAY2021	TE TE Connectivity	
		CHK J.GUPPY 13MAY2021		
		APVD J.OPEL 13MAY2021	NAME STIRRUP, 1/0, TYPE II, WHITE CODED, AMPACT	
DIMENSIONS: INCHES		TOLERANCES UNLESS OTHERWISE SPECIFIED:	PRODUCT SPEC —	
		0 PLC ±	APPLICATION SPEC —	
		1 PLC ±	SIZE CAGE CODE DRAWING NO RESTRICTED TO	
		2 PLC ±	A3 00779 C-81667	
		3 PLC ±	SCALE NTS SHEET 1 OF 1 REV A	
		4 PLC ±		
		ANGLES ±		
MATERIAL		FINISH	CUSTOMER DRAWING	
		—		