

**SPECIFICATION CONTROL DRAWING**

**8222C5421**

**CHEMINAX**

82 OHM, AWG 22, 19 STRANDS OF AWG 34,  
TRIAxIAL CABLE

Date: 12-2-15  
Revision: B

THIS SPECIFICATION SHEET FORMS A PART OF THE LATEST ISSUE OF RAYCHEM SPECIFICATION 1200.

**CONSTRUCTION DETAILS**

**ELECTRICAL CHARACTERISTICS**

DIMENSIONS ARE NOMINAL VALUES IN INCHES, UNLESS OTHERWISE DESIGNATED.

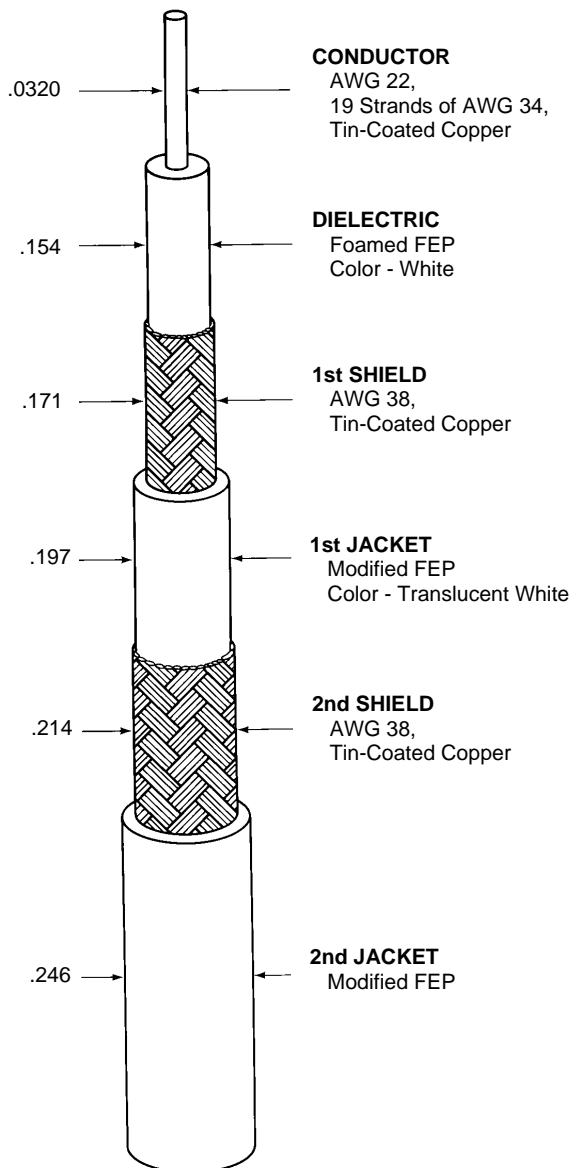

CHARACTERISTIC IMPEDANCE	82 ± 5 ohms, Method B
CAPACITANCE	14.9 pF/ft. (nominal)
VELOCITY OF PROPAGATION	83% (nominal)

**ADDITIONAL REQUIREMENTS**

**ELECTRICAL**

CONDUCTOR RESISTANCE	14.8 ohms/1000 ft. (nominal)
INSULATION RESISTANCE CONDUCTOR TO SHIELD	10,000 megohms (minimum) for 1000 ft.
JACKET FLAWS SPARK TEST IMPULSE TEST	1.0 kV (rms) 6.0 kV (peak)
VOLTAGE WITHSTAND CONDUCTOR TO SHIELD SHIELD TO SHIELD	1500 volts (rms) 1000 volts (rms)

**ENVIRONMENTAL**

FLAMMABILITY	Method B
HEAT SHOCK	225°C
LOW TEMPERATURE-COLD BEND	-55°C/7.00 inch mandrel
VOLTAGE WITHSTAND (Post Environmental)	1000 volts (rms), 1 minute

**PHYSICAL**

INSULATION (DIELECTRIC) ELONGATION TENSILE STRENGTH	50% (minimum) 600 lbf/in <sup>2</sup> (minimum)
JACKET (each) ELONGATION TENSILE STRENGTH	200% (minimum) 2000 lbf/in <sup>2</sup> (minimum)
JACKET THICKNESS 1st JACKET 2nd JACKET	.013 inch (nominal) .016 inch (nominal)
SHIELD COVERAGE (each)	90% (minimum), 95% (nominal)

WEIGHT	49.6 lbs/1000 ft. (nominal)
--------	-----------------------------

**ENGINEERING REFERENCE**

TEMPERATURE INDEX	200°C for 3000 hours (minimum)
-------------------	--------------------------------

Designate outer jacket color with a dash number in accordance with MIL-STD-681. Unless otherwise specified, outer jacket color will be Translucent White designated by a "-9X" appended to the part number, (e.g. 8222C5421-9X). Other codes and suffixes may be added to the part number, as necessary, to capture any additional requirements imposed by the purchase order.

Users should evaluate the suitability of this product for their application. Specifications are subject to change without notice. Tyco Electronics Corporation also reserves the right to make changes in materials or processing, which do not affect compliance with any specification, without notification to Buyer.

