

THIS DRAWING IS UNPUBLISHED. RELEASED FOR PUBLICATION, 19 .
 © COPYRIGHT 1992 BY AMP OF CANADA LTD. ALL INTERNATIONAL RIGHTS RESERVED.

LOC	DIST	P	F	REVISIONS					
				ZONE	LTR	DESCRIPTION	DATE	DWN	APPD
BG	1				D	REV PER LC00-0086-96	24JUN96	-	GM
					E	REV PER LC00-0103-96	13MAR97	MS	GM

- △ 1 ADJACENT TO LARGEST WIRE GROOVE.
 - 2. DIMENSIONS ARE FOR REFERENCE ONLY.
 - △ 3 'SB' INDICATES SMOOTH BODY (COMPACT) VERSUS STANDARD WIRE STRANDING
- 

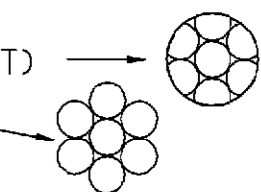
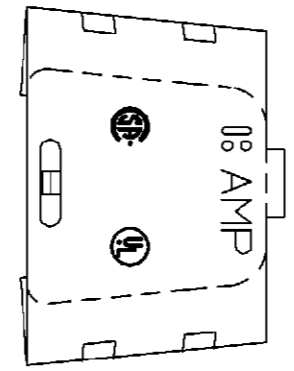
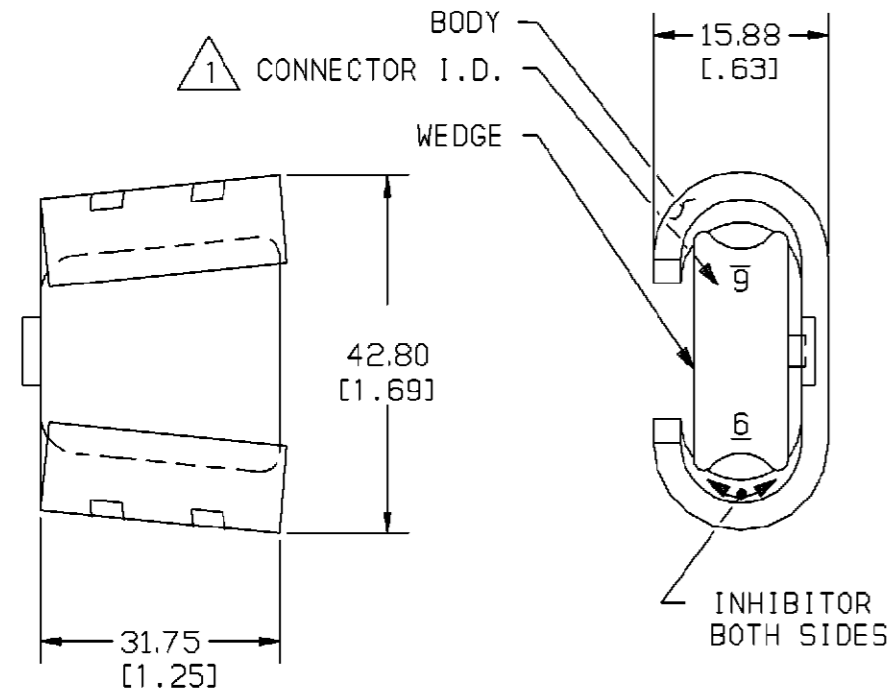

1-83592-0	3/16" GALV ST, #6 AL/CU TO #6 AL/CU, 3/16" GALV ST	6-6	1-83447-3
83592-9	1/4" GALV ST, #4 AL/CU TO #6 AL/CU, 3/16" GALV ST	4-6	1-83447-2
83592-8	1/4" GALV ST, #4 AL/CU TO #4 AL/CU, 1/4" GALV ST	4-4	1-83447-0
83592-7	5/16" GALV ST, #2 AL/CU TO #6 AL/CU, 3/16" GALV ST	2-6	83447-9
83592-3	3/8" GALV ST, 1/0 AL TO #4 AL/CU, 1/4" GALV ST	1/0-4	83447-8
83592-6	5/16" GALV ST, #2 AL/CU TO #4 AL/CU, 1/4" GALV ST	2-4	83447-7
83592-5	5/16" GALV ST, #2 AL/CU TO #2 AL/CU, 5/16", 9/32" GALV ST	2-2	83447-5
83592-2	3/8" GALV ST, 1/0 AL TO #2 AL/CU, 5/16", 9/32" GALV ST	1/0-2	83447-4
1-83592-1	3/8" GALV ST, 1/0 AL TO 1/0 AL/CU, 3/8" GALV ST	△ 3 1/0SB-1/0SB	83447-3
83592-4	3/8" GALV ST, 1/0 AL TO #6 AL/CU, 3/16" GALV ST	1/0-6	83447-1
CORE MINIWEDGE PART NUMBER	ACCOMMODATES	CONN I.D.	PART NO

METRIC

DO NOT SCALE PRINT. UNLESS SPECIFIED DIMENSIONS IN mm [INCHES] TOLERANCES ON: 2 PLC DEC ± - 3 PLC DEC ± - ANGLES ± -	DR R. SEUCHARAN 09DE92 CHK D. RENNOX 01FE93 APPD R. LARICCHIA 01FE93	AMP AMP of CANADA Ltd. Markham, Ont.	
MATERIAL ALUMINUM ALLOY	APPD	NAME CONNECTOR, SYMMETRICAL, TELCO, MINIWEDGE	
FINISH	PRODUCT SPEC 108-1430	SIZE B	CAGE CODE 09482
	APPLICATION SPEC -	DRAWING NO 83447	
	WEIGHT -	SCALE NTS	SHEET 1 OF 1