

THIS DRAWING IS UNPUBLISHED. RELEASED FOR PUBLICATION 20
 © COPYRIGHT 20 BY - ALL RIGHTS RESERVED.

creo
 Creo Parametric 2.0
DO NOT REVISE
EXCEPT BY CAD

REVISIONS				
P	LTR	DESCRIPTION	DATE	APVD
B3		REV. BY ECO 17-007730	29MAY2017	HC WLS

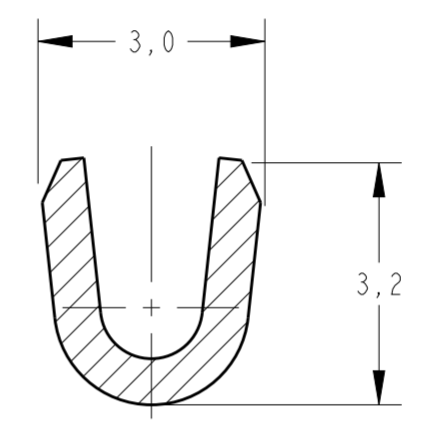
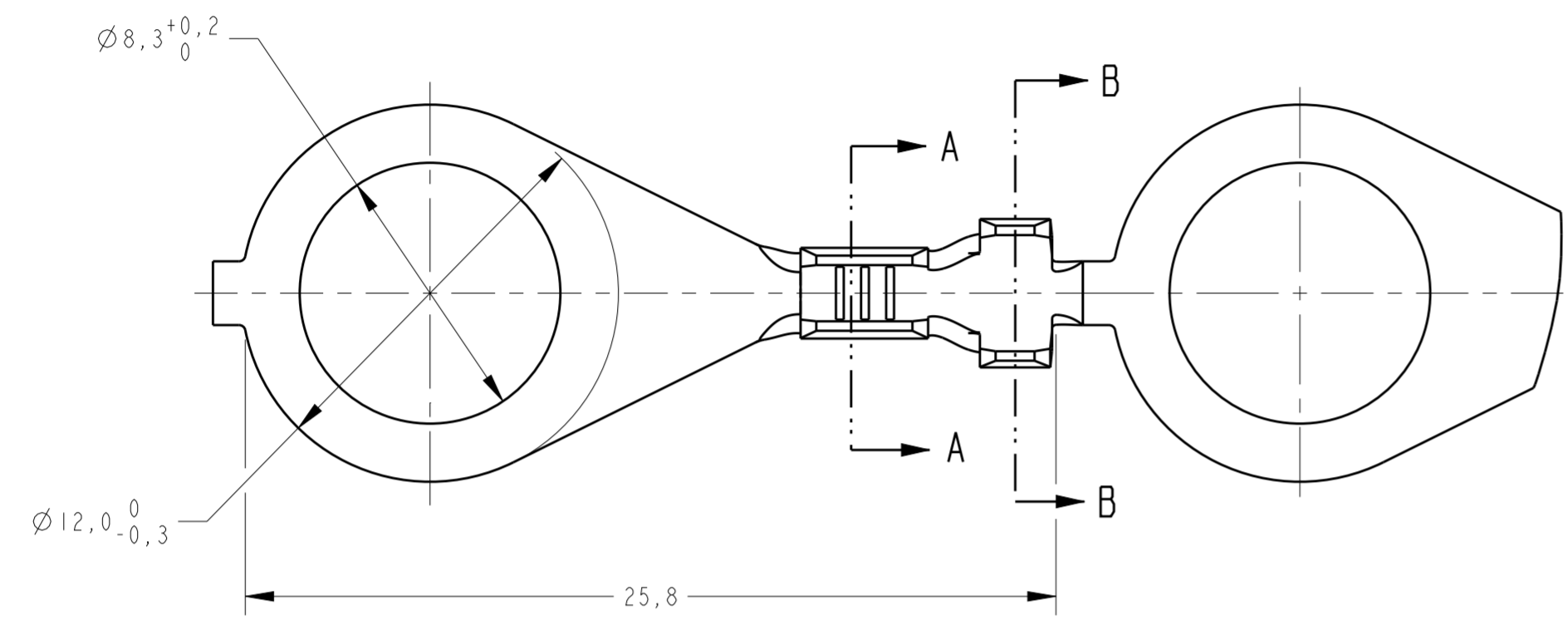

SECTION A-A
 SCALE 10:1

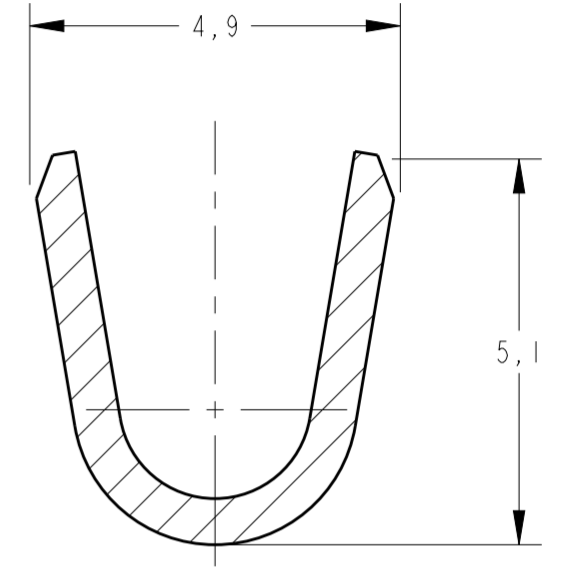

SECTION B-B
 SCALE 10:1

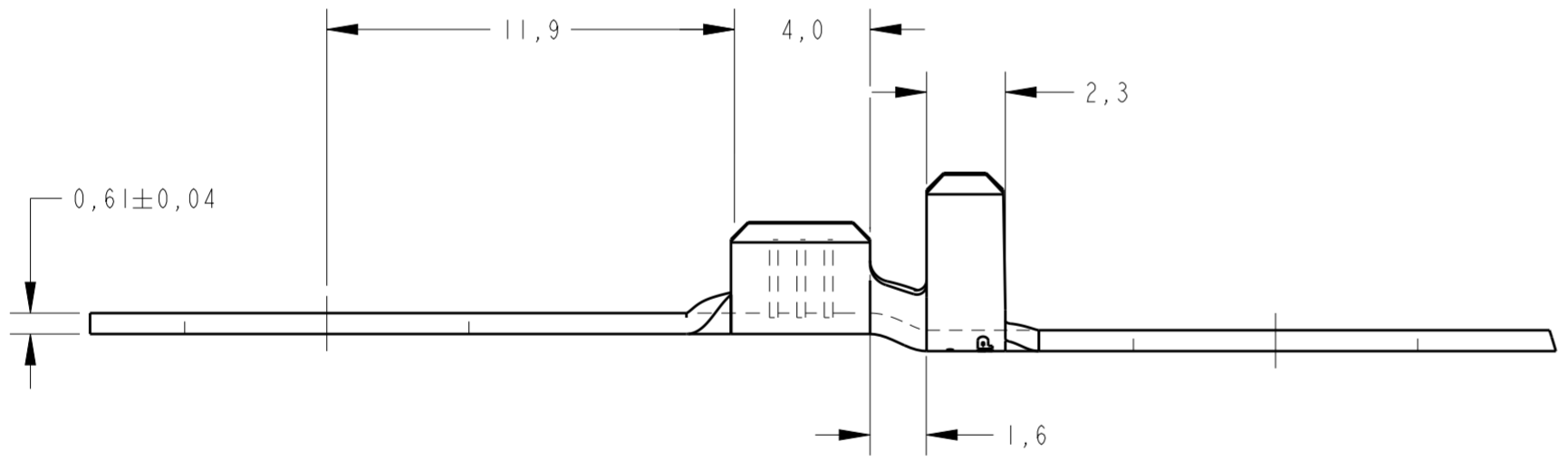

⚠ - C.A 272

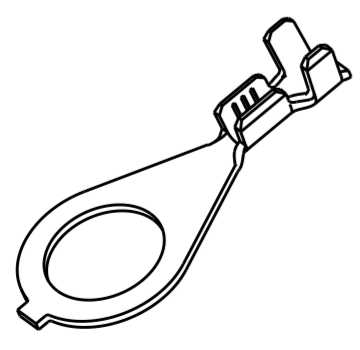

PERSPECTIVE VIEW
 SCALE 2:1

INS.DIA.RANGE	WIRE RANGE
2,0-3,3mm	0,5-1,0mm ²

OBSOLETE	ESTANHADO / TINNED	BRONZE FOSF. / PHOS. BRONZE	880630-4
OBSOLETE	—	BRONZE FOSF. / PHOS. BRONZE	880630-3
	ESTANHADO / TINNED	LATÃO / BRASS	880630-2
	—	LATÃO / BRASS	880630-1
	FINISH	MATERIAL ⚠	PART NUMBER

THIS DRAWING IS A CONTROLLED DOCUMENT.		DWN NCLAPRESA 27MAY2015	TE Connectivity STE	
DIMENSIONS: mm		CHK FFORTUNATO 27MAY2015		
TOLERANCES UNLESS OTHERWISE SPECIFIED:		APVD DAOLIVEIRA 27MAY2015		
0 PLC ± 1 PLC ±0,3 2 PLC ± 3 PLC ± 4 PLC ± ANGLES ±° FINISH		NAME -		
MATERIAL SEE TABLE	SEE TABLE	PRODUCT SPEC -	RING TONGUE	
		APPLICATION SPEC -	SIZE A2	CAGE CODE -
		WEIGHT -	DRAWING NO. C-880630	RESTRICTED TO -
		Customer Drawing	SCALE 5:1	SHEET 1 OF 1
				REV B3