

REVISIONS				
P	LTM	DESCRIPTION	DATE	APPV
G18		ECR-22-156104	07NOV2022	DC FL
G19		ECR-23-168751	15MAR2023	DC FL
G20		ECR-24-209324	21JUN2024	SM FL

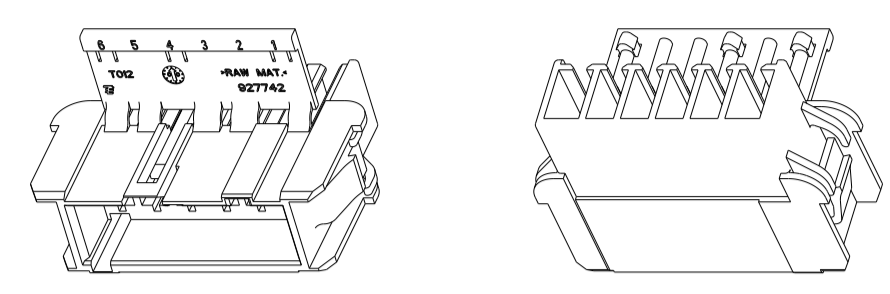
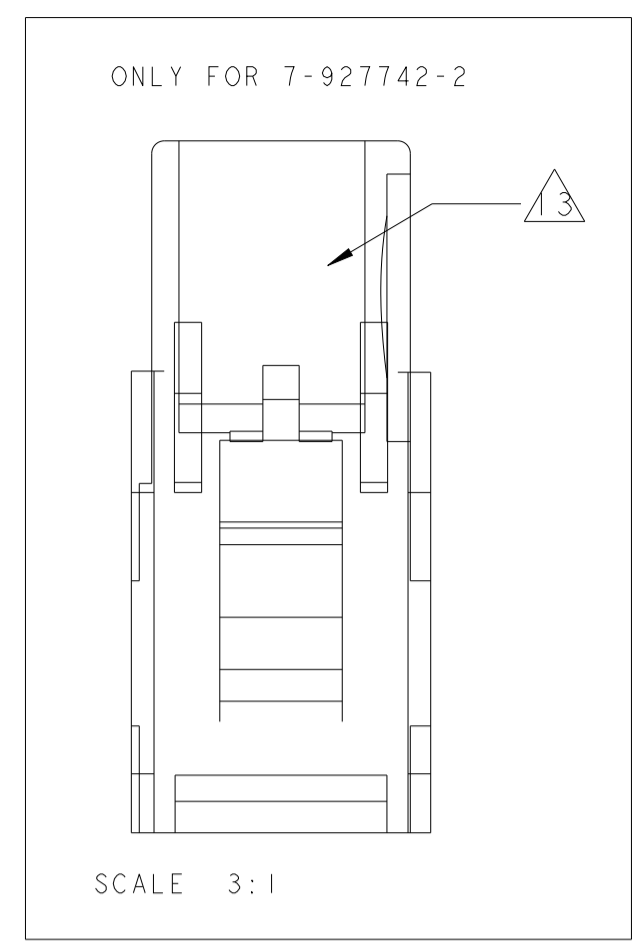
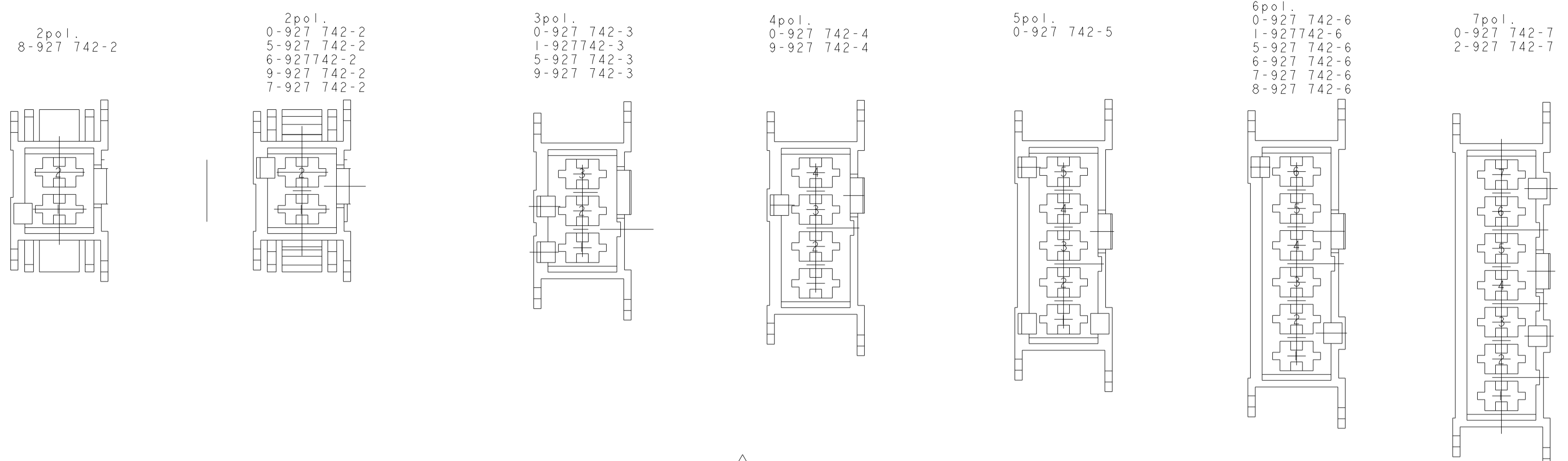

SCALE 1:1

TYPICAL CAVITY SUITABLE FOR:
 FASTIN-FASTON TAB CONTACTS 6.3 mm SRS:
 P/N: 60294, 0.3-0.8 mm² WIRE RANGE
 160691, 0.3-0.8 mm² WIRE RANGE
 AMPLIVAR CONTACTS:
 P/N: 141051, 0.1-0.5 mm² WIRE RANGE
 142411, 0.3-1.6 mm² WIRE RANGE
 MAX. INSULATION DIA. 2.8 mm.
 MAX. INSULATION CRIMP WIDTH 3.3 mm.

- 2) SEE TABLE FOR SUITABLE CENTERPART.
- 3) CIRCUIT IDENTIFICATION No. ACCORDING TO DIN 1451.
- 4) POLARIZATION KEYS DIMENSIONS AND POSITIONS ARE ACCORDING TO "RAST 5" NORM
- 5) TE TRADEMARK LOGO AND TE PART NUMBER (OPTIONAL)
- 6) PACKAGING ACCORDING TO TE SPEC. 107-20248
- 7) PRODUCT ACCORDING TO IEC 60335-1 NORM
- 8) NOT TOOLED YET
- 9) SPECIAL VERSION WITH LARGER GAP "A"
- 10) PRELIMINARY PART - NOT YET RELEASED FOR PRODUCTION
- 11) DOUBLE SOURCE RESIN: ALTERNATIVE RESIN UNDER APPROVAL.
- 12) SPECIAL VERSION WITH MAXIMUM GAP "A"
- 13) ONLY FOR 7-927742-2, ADDED COLOR MARKING ON THE AREA HIGHLIGHTED. TEMPORARY SOLUTION FOR NEW PRODUCT INTRODUCTION

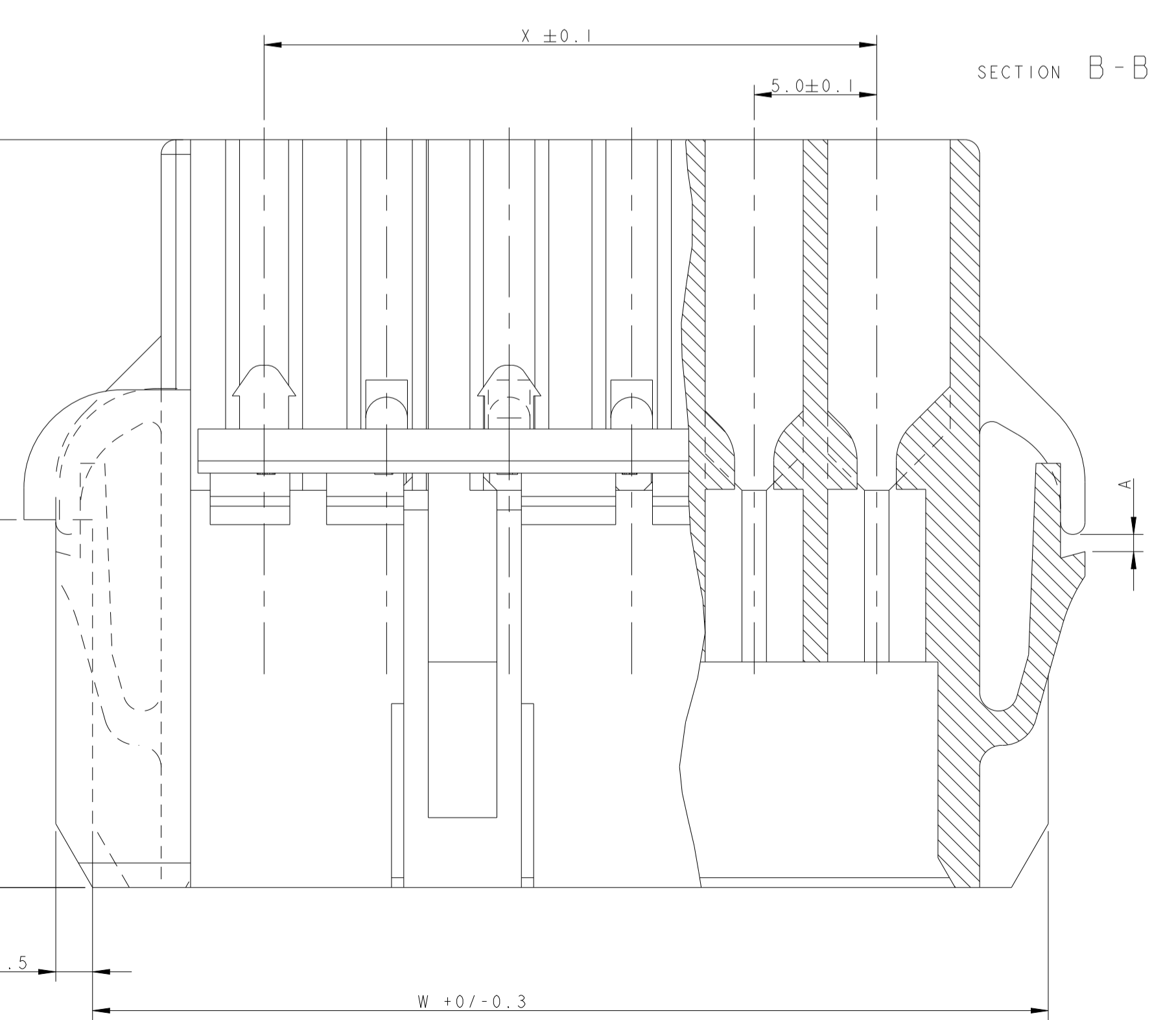
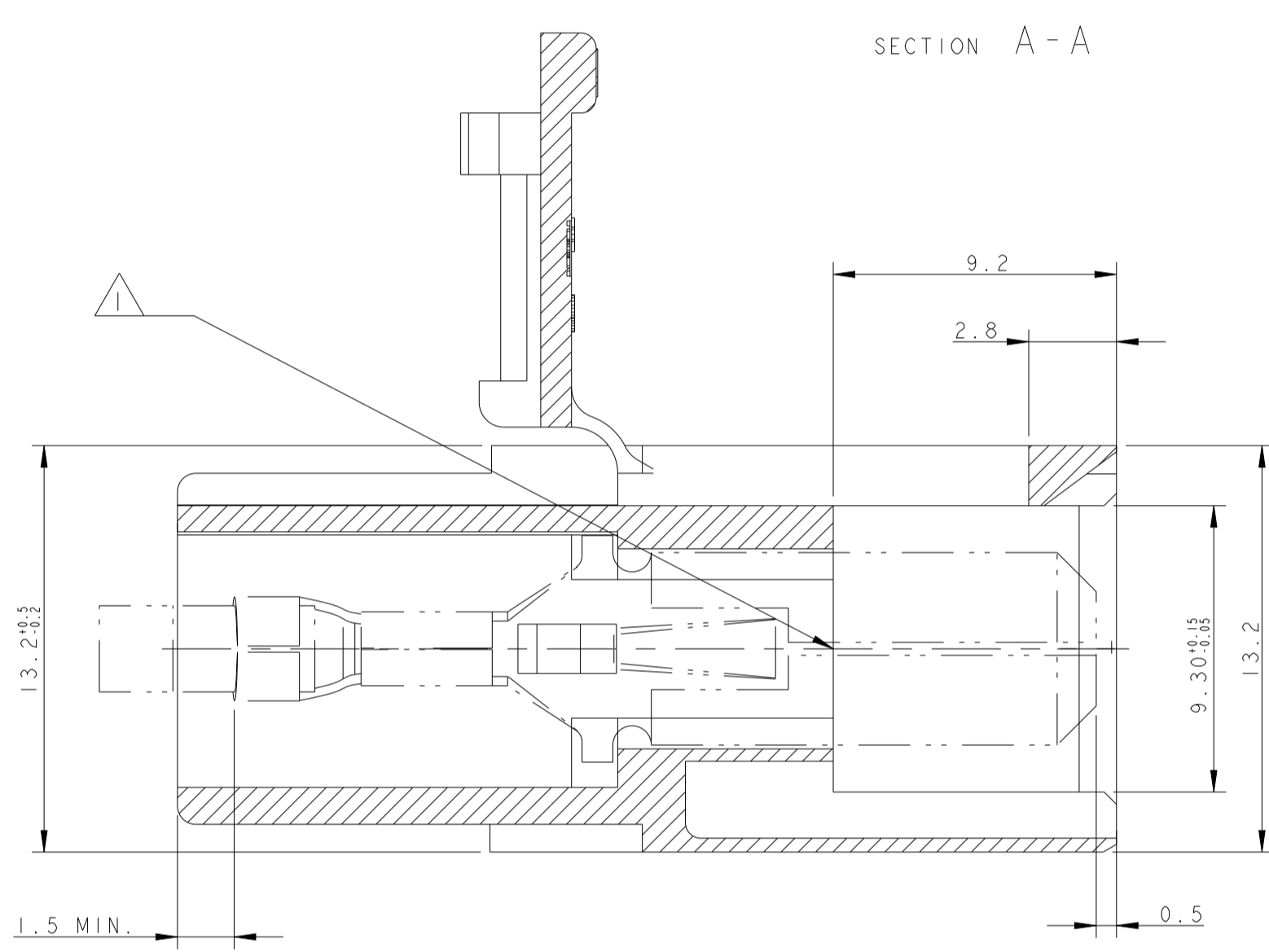
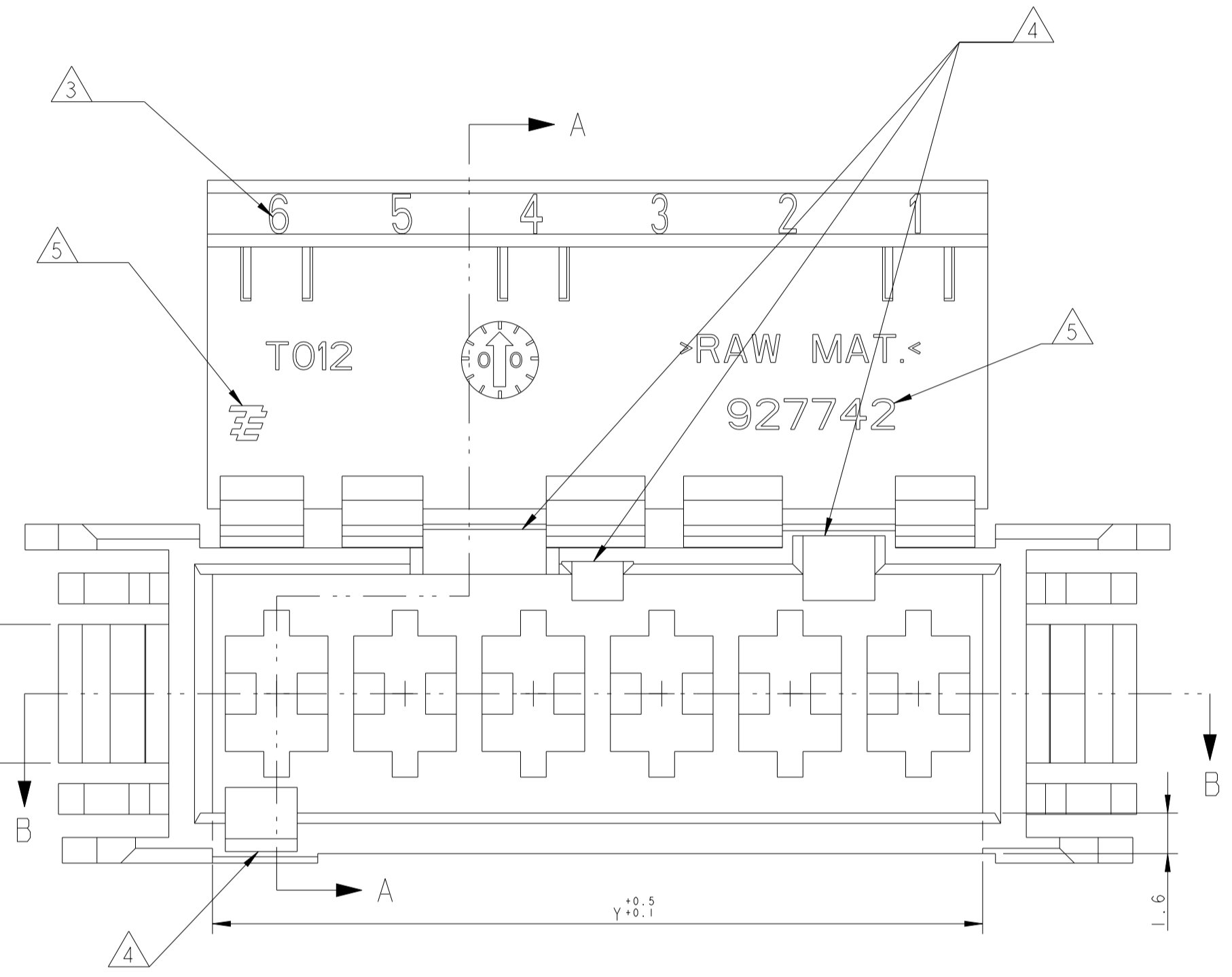

PANEL CUT DIMENSIONS SCALE 1:1

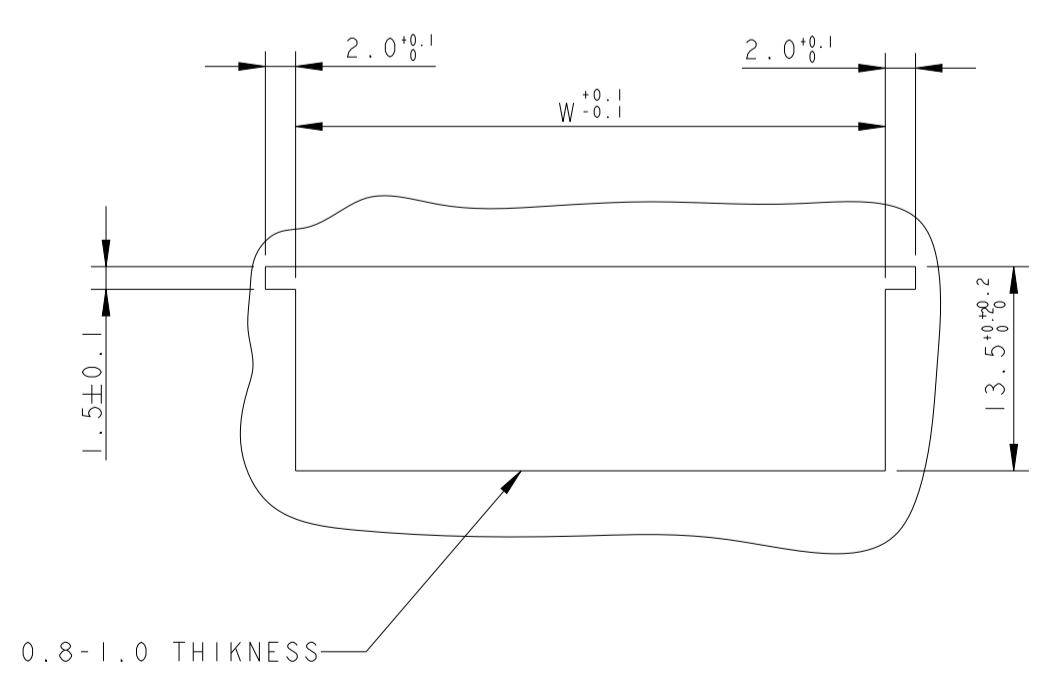

	POS.	W	X	Y	PART-NO.	STANDARD TIMER	MATERIAL	COLOUR	NOTE
	11	-	-	-	-	-	-	-	
	10	-	-	-	-	-	-	-	
	9	-	-	-	-	-	-	-	
	-	-	-	-	-	-	-	-	
OBSELETE	7	45	30	35	2-927 742-7	0-927 740-7	UL94V-2	black	
	7	45	30	35	0-927 742-7	0-927 740-7	UL94V-2	natur	
	6	40	25	30	8-927 742-6	0-927 740-6	UL94-V0	natur	7
	6	40	25	30	7-927 742-6	0-927 740-6	UL94V-2	natur	7
	6	40	25	30	6-927 742-6	0-927 740-6	UL94V-0	black	
	6	40	25	30	5-927 742-6	0-927 740-6	UL94V-0	natur	
	6	40	25	30	1-927742-6	927740-6	UL94-V2	natur	7 9
	6	39	25	30	0-927 742-6	0-927 740-6	UL94V-2	natur	
	5	35	20	25	0-927 742-5	0-927 740-5	UL94V-2	natur	9
	4	30	15	20	9-927 742-4	0-927 740-4	UL94V-2	natur	7
	4	30	15	20	0-927 742-4	0-927 740-4	UL94V-2	natur	
	3	25	10	15	9-927 742-3	0-927 740-3	UL94V-2	natur	7
	3	25	10	15	5-927 742-3	0-927 740-3	UL94V-0	natur	
OBSELETE	3	25	10	15	2-927 742-3	0-927 740-3	UL94V-2	grey	
	3	25	10	15	1-927742-3	927740-3	UL94V-2	natur	7 9
OBSELETE	3	25	10	15	0-927 742-3	0-927 740-3	UL94V-2	natur	
	2	20	5	10	7-927742-2	-	UL94V-2	natur	7 12 13
	2	20	5	10	9-927 742-2	4-927 740-2	UL94V-2	natur	7
	2	20	5	10	8-927 742-2	-	UL94V-2	natur	7
7	2	20	5	10	6-927742-2	-	UL94-V0	blue	7
	2	20	5	10	5-927 742-2	4-927 740-2	UL94V-0	natur	
	2	20	5	10	0-927 742-2	4-927 740-2	UL94V-2	natur	9

THIS DRAWING IS A CONTROLLED DOCUMENT. DWN: H. YAALI, 22MAR2005. CHK: G. TURCO. APVD: -

TE Connectivity

2-12 POS. FASTIN-FASTON CONNECTOR TAB HOUSING RAST 5, PANEL MOUNT VERSION

108-20256 APPLICATION SPEC

SIZE: A100779 C=927742

SCALE: 5:1 SHEET: 1 OF 1 REV: G20