

LOC	DIST	REVISIONS					
A1	-	P	LTR	DESCRIPTION	DATE	DWN	APVD
		A		NEW DRAWING	06NOV2008	CA	HS
		A1		SEE E-11-001103	17JAN2011	HS	RH
		A2		ECR-23-163858	16JAN2023	BI	YD
		A3		ECR-23-171338	04APR2023	BI	AB

ASSEMBLAGE CONDITION
Montagezustand

DELIVERY CONDITION
Anlieferungszustand

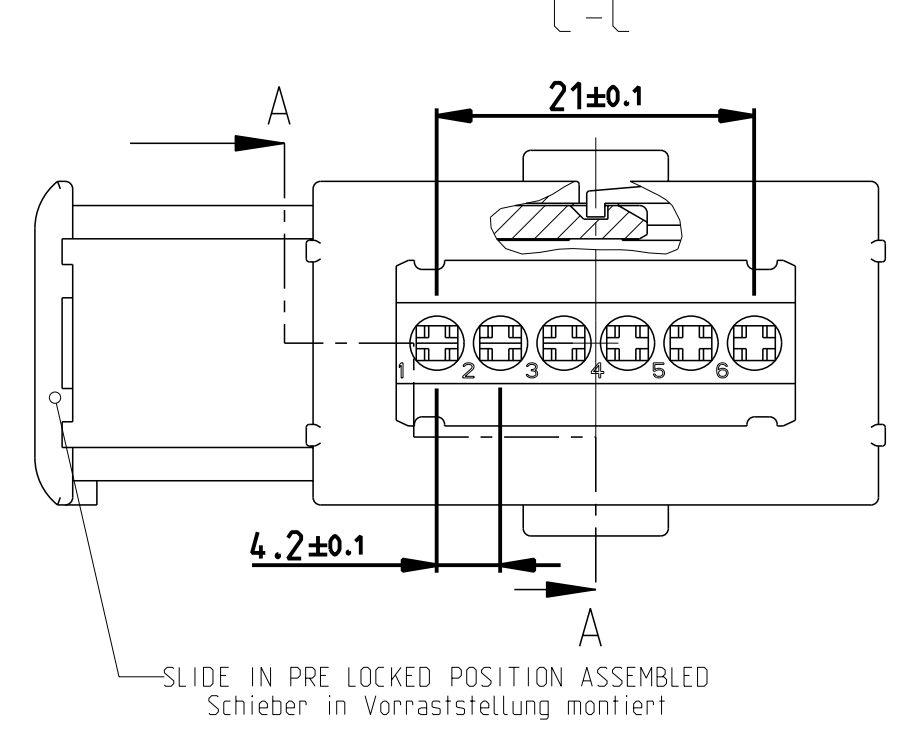
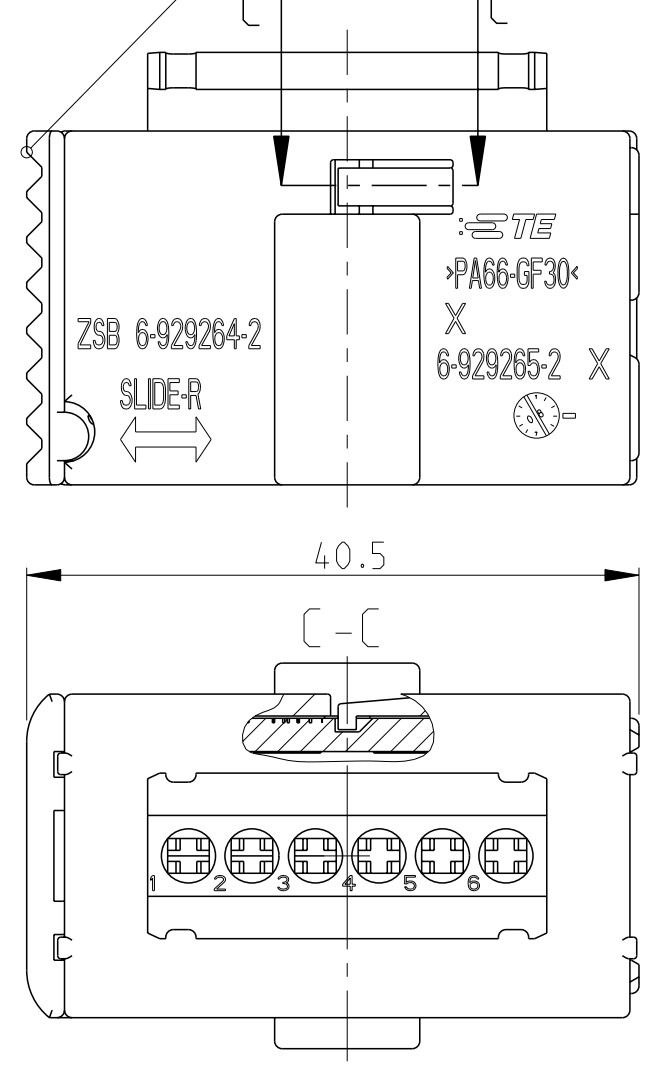

NOTES
Bemerkungen

- 1 AMP-LOGO OR TE-LOGO
AMP-Logo oder TE-Logo
- 2 ORDER-NUMBER
Bestell-Nummer
- 3 REVISIONS-NUMBER
Werkzeugaenderungsindex
- 4 CAVITY MARKING
Nestmarkierung
- NV CUSTOMER SIGN
Kunden-Kurzzeichen
- 5 PACKAGING IN CARTON
Verpackung in Karton
- 6 MATERIAL MARKING
Werkstoffkennzeichnung
- 7 PRODUCTION-DATE
Produktions-Datum

printed on 6 Apr 2023 10:09 (Maroc) from 1E522086
WAS 97-52263-104

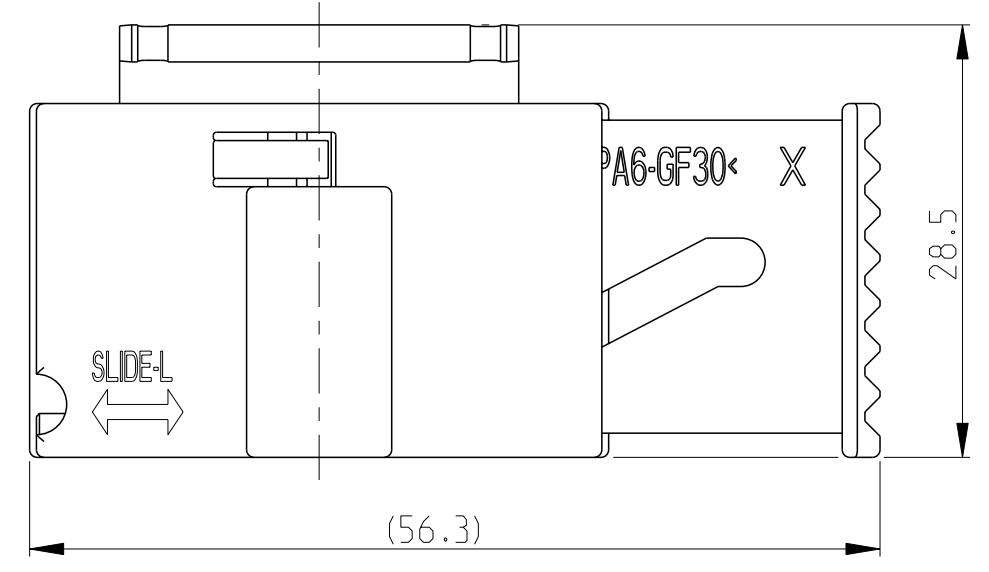
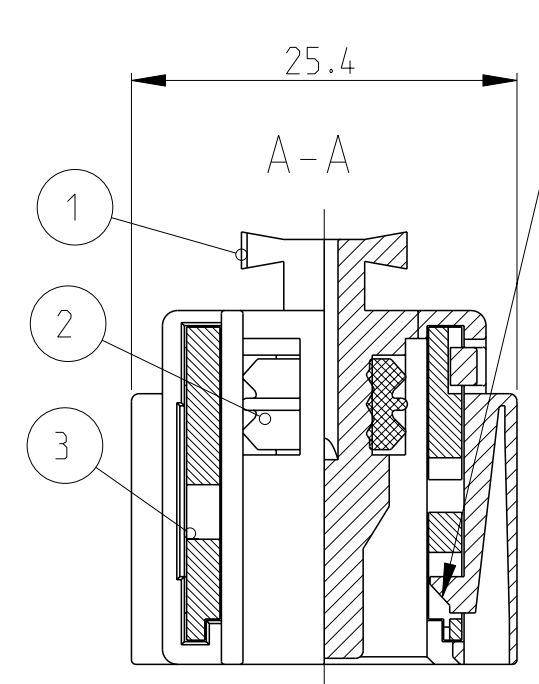
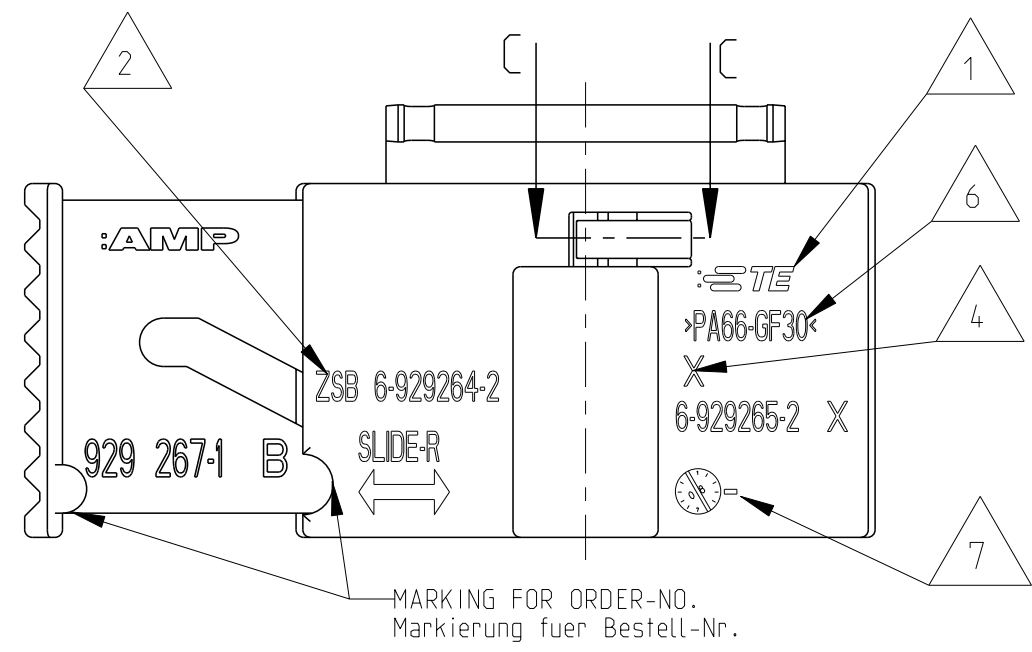

PN 6-929264-2
CODING N
Kodierung N 1:1

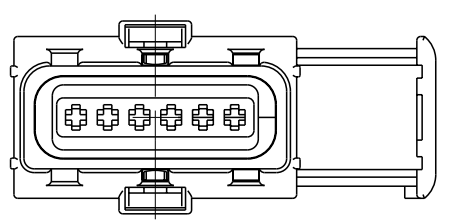

TE ORDER NO TE BESTELLNUMMER	REV	QTY	DESCRIPTION NAME	MATERIAL	SURFACE COLOR	WEIGHT GEWICHT [g]	ITEM NO
6-929264-2	D	1	SLIDE	PA6-GF30	RED		3
		1	SEALING	SILICON	RED		2
		1	MT2 HSG. 6POS. COD. N	PA66-GF30	BLACK	-	1

MICRO TIMER II	962 876-2	963 711-2	0.5 - 1.0	CuFe2	PRE TIN PLATED	FOR THE PRODUCTION	878 616-2	HAND TOOL 734 560-1	963 530-1
CONTACT	ORDER NO. STRIP FORM	ORDER NO. LOOSE PIECE	WIRE RANGE MM ²	MATERIAL	FINISH	APPLICATOR	CRIMP TOOL HAND TOOL		SEAL

THIS DRAWING IS A CONTROLLED DOCUMENT FOR TYCO ELECTRONICS CORPORATION IT IS SUBJECT TO CHANGE AND THE CONTROLLING ENGINEERING ORGANIZATION SHOULD BE CONTACTED FOR THE LATEST REVISION.

DWN C. Anghel 06NOV2008
CHK H. Schmitt 07NOV2008

Tyco Electronics Tyco Electronics AMP GmbH
64625 Bensheim, Germany

NAME: MT2 HOUSING, 6POS., ASS'Y
MT2 Gehäuse, 6pol., Ass'y

SIZE: A2 CAGE CODE: 00779 DRAWING NO: 929264 RESTRICTED TO: A4

WEIGHT: 16.1g SCALE: 2:1 SHEET 1 OF 1 REV: A4

Customer Drawing