

THIS DRAWING IS UNPUBLISHED.

RELEASED FOR PUBLICATION

REVISIONS

© COPYRIGHT - TE Connectivity Ltd.

ALL RIGHTS RESERVED.

P	LTR	DESCRIPTION	DATE	DWN	APVD
	A	INITIAL DRAWING	12SEP2019	VM	DH

Part Numbering System

Typical Part Number 1722 -C - 1102

Model Number:
Four digit code from table above.

Mounting (see outline dimension drawings):
A = Studs on bottom B = Studs on top C = Studs on side

Timing Code:
Four-digit code for any value between 50ms.

A typical part number for an adjustable timer would be 1722-C-1102. This is a DC unit in the -55°C to +125°C temperature range with a 2 form C (DPDT) contact arrangement in a style "C" mounting, with a maximum time delay of 11s.

Electrical Specifications

Timing Range —
1600 series (fixed) — 50 ms to 600 s
1700 series (adjustable) — 50 ms to 240 s

Tolerance — ±10% or 10 ms, whichever is greater

Recycle Time — 10 ms (DC input), 50ms (AC input)

Recovery Time — 10 ms (DC input), 50ms (AC input)

Input Voltage — 18 to 31Vdc, 105 to 125Vac, 400 Hz

Current Drain (at 25°C, 28Vdc) — DC Coil, 10A contacts —
1- and 2-pole — 135mA maximum

AC or DC Coil, 4A contacts —
1-pole — 100mA maximum
2-pole — 150mA maximum
3- and 4-pole — 200mA maximum

Contact Ratings —
DC Coil, 10A contacts —
 10A resistive @ 30Vdc
 5A inductive @ 30Vdc
 5A resistive @ 115 Vrms, 400 Hz
 3A inductive @ 115 Vrms, 400 Hz

AC or DC Coil, 4A contacts —
 4A resistive @ 30Vdc
 1A inductive @ 30Vdc
 2A resistive @ 115 Vrms, 400 Hz
 1A inductive @ 115 Vrms, 400 Hz

Environmental Specifications

Temperature Range —
 -55°C to +85°C or -55°C to +125°C

Vibration — 20 G's, 10 - 2,000 Hz

Shock — 50 G's, 11 ± 1ms duration

Insulation Resistance — 1,000 megohms, min., at 500Vdc, all terminals to case

Dielectric Strength — 1,000Vrms, 60 Hz., at sea level, all terminals to case

Sealing — Hermetic, 1.3 in. (33.0mm) of mercury

Life — 100,000 operations, min.

Weight —
4A units — 4.5 oz (127.6g) max.
10A units — 8.5 oz (240g) max.

Specifications by Model Number – 4 Amp Contact Versions

Fixed Timer Model Number	Adjustable Timer Model Number	Input Voltage	Temperature Range	Housing Length (Dim. "A")	Contact Arrangement
1601	1701	DC	-55°C to +85°C	1.656 [42.06]	1 Form C (SPDT)
1602	1702	DC	-55°C to +85°C	1.656 [42.06]	2 Form C (DPDT)
1603	1703	DC	-55°C to +85°C	2.0 [50.8]	3 Form C (3PDT)
1604	1704	DC	-55°C to +85°C	2.0 [50.8]	4 Form C (4PDT)
1621	1721	DC	-55°C to +125°C	1.656 [42.06]	1 Form C (SPDT)
1622	1722	DC	-55°C to +125°C	1.656 [42.06]	2 Form C (DPDT)
1623	1723	DC	-55°C to +125°C	2.0 [50.8]	3 Form C (3PDT)
1624	1724	DC	-55°C to +125°C	2.0 [50.8]	4 Form C (4PDT)
1651	1751	AC	-55°C to +85°C	2.0 [50.8]	1 Form C (SPDT)
1652	1752	AC	-55°C to +85°C	2.0 [50.8]	2 Form C (DPDT)
1653	1753	AC	-55°C to +85°C	2.375 [60.33]	3 Form C (3PDT)
1654	1754	AC	-55°C to +85°C	2.375 [60.33]	4 Form C (4PDT)
1671	1771	AC	-55°C to +125°C	2.0 [50.8]	1 Form C (SPDT)
1672	1772	AC	-55°C to +125°C	2.0 [50.8]	2 Form C (DPDT)
1673	1773	AC	-55°C to +125°C	2.375 [60.33]	3 Form C (3PDT)
1674	1774	AC	-55°C to +125°C	2.375 [60.33]	4 Form C (4PDT)

Specifications by Model Number – 10 Amp Contact Versions

Fixed Timer Model Number	Adjustable Timer Model Number	Input Voltage	Temperature Range	Housing Length (Dim. "A")	Contact Arrangement
1610	1710	DC	-55°C to +85°C	2.419 [61.44]	1 Form C (SPDT)
1620	1720	DC	-55°C to +85°C	2.419 [61.44]	2 Form C (DPDT)

Adjustable Timing Formula (1700 types)

The resistance required to obtain timing within this range is determined by using the formula:

$$R_x = 400K (T/T_{max.}) - 40K, \text{ where}$$

R_x = External Resistance in Ohms,
 T = Desired Time in Seconds, and
 $T_{max.}$ = Maximum Time (Code).

A high quality deposited carbon ±1%, 0.1W (min.) resistor is recommended for external resistance.

Product Facts

- AC/DC input delay on operate timer offered in fixed (1600) and adjustable (1700) types
- Up to 10A loads
- CMOS digital design
- Hermetic package
- Built to MIL-R-83726 environmentals
- Many customizing options
 - Extended timing ranges
 - Tighter timing tolerances
 - Header and mounting
 - 115Vac, 60 Hz. input types

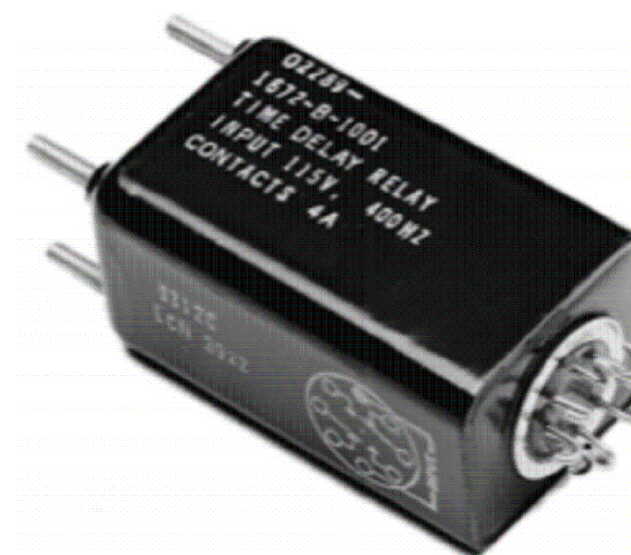

THIS DRAWING IS A CONTROLLED DOCUMENT.		DWN VM 12SEP2019	TE Connectivity				
		CHK RV 12SEP2019					
DIMENSIONS: INCHES 		APVD DH 12SEP2019	NAME				
TOLERANCES UNLESS OTHERWISE SPECIFIED: 0 PLC ± - 1 PLC ± - 2 PLC ± - 3 PLC ± - 4 PLC ± - ANGLES ± -		PRODUCT SPEC	1600/1700 SERIES DELAY ON OPERATE TIMERS				
MATERIAL		FINISH	APPLICATION SPEC	SIZE	CAGE CODE	DRAWING NO	RESTRICTED TO
				A3	-	1600/1700-SERIES	-
CUSTOMER DRAWING			WEIGHT	SCALE	SHEET	REV	
				NTS	1 OF 2	A	

THIS DRAWING IS UNPUBLISHED.

RELEASED FOR PUBLICATION

REVISIONS

© COPYRIGHT - TE Connectivity Ltd.

ALL RIGHTS RESERVED.

P	LTR	DESCRIPTION	DATE	DWN	APVD
-	-	SEE SHEET 1	-	-	-

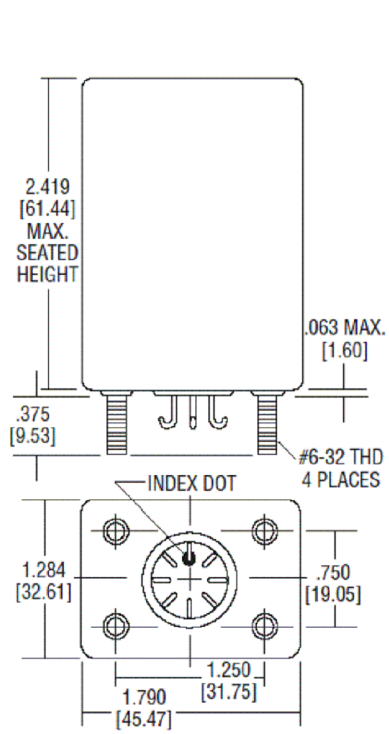

Mounting Option A

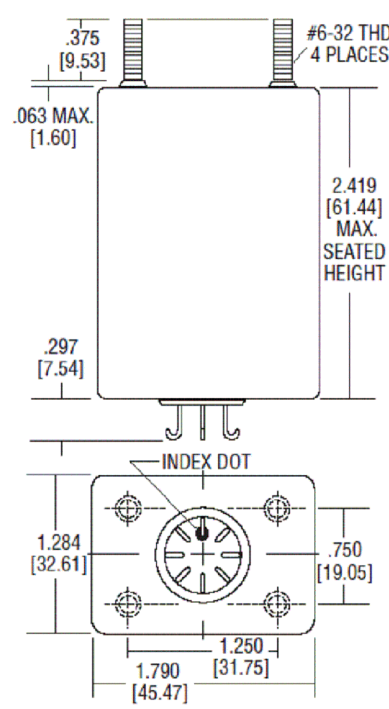

Mounting Option B

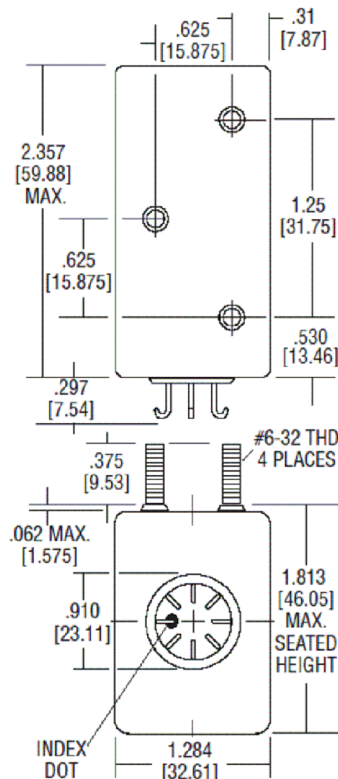

Mounting Option C

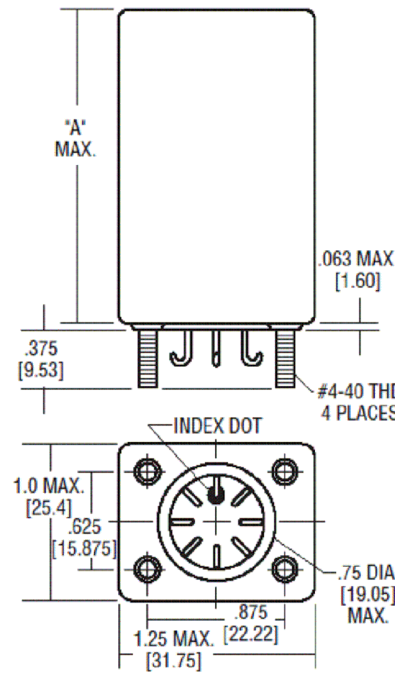

Mounting Option A

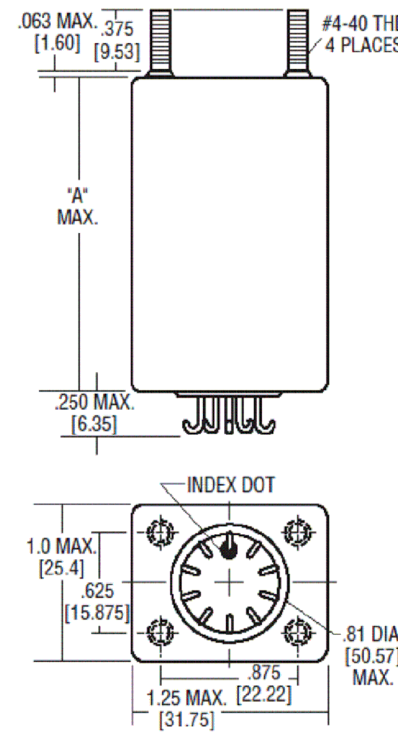

Mounting Option B

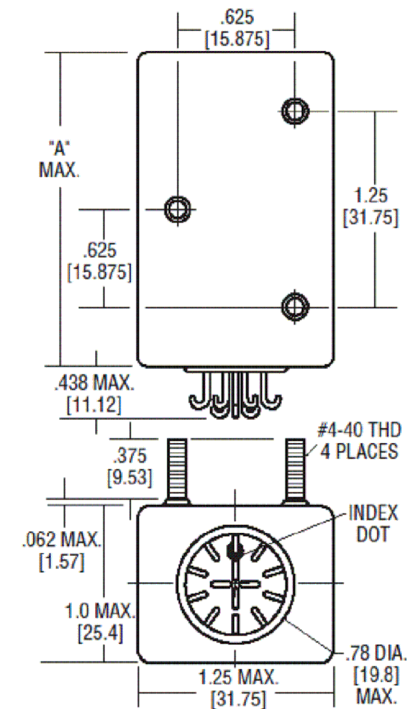

Mounting Option C

Wiring Diagrams

1600 Series (Fixed)

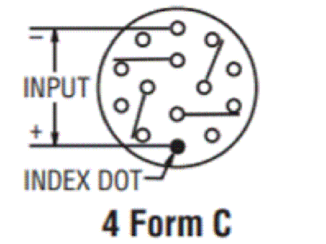
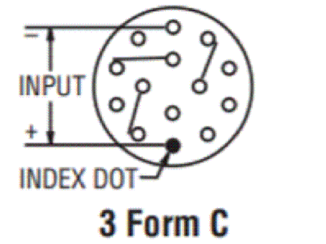
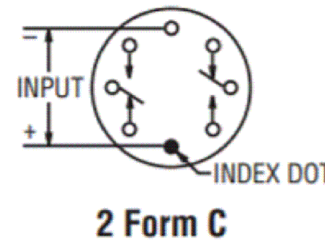
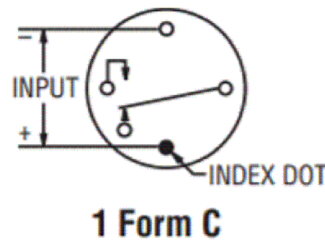

1700 Series (Adjustable)

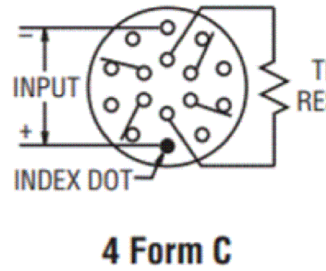
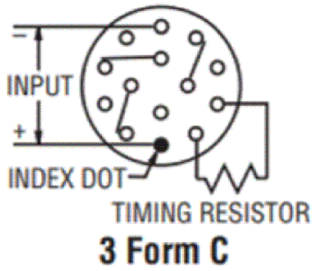
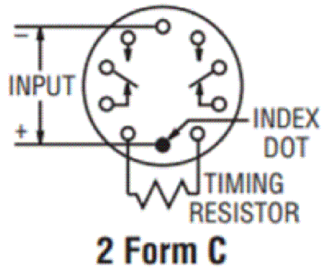
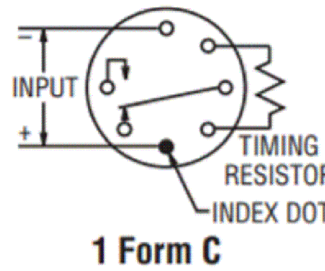

ALL DIMENSIONS ARE IN INCHES(MM)

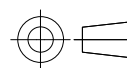
THIS DRAWING IS A CONTROLLED DOCUMENT.		DWN VM 12SEP2019	 TE Connectivity		
DIMENSIONS: INCHES		CHK RV 12SEP2019			
TOLERANCES UNLESS OTHERWISE SPECIFIED:		APVD DH 12SEP2019	SIZE CAGE CODE DRAWING NO RESTRICTED TO A3 - C-1600/1700-SERIES -		
		PRODUCT SPEC -			
0 PLC ± - 1 PLC ± - 2 PLC ± - 3 PLC ± - 4 PLC ± - ANGLES ± -		APPLICATION SPEC -	WEIGHT -		
MATERIAL -		CUSTOMER DRAWING			