

REVISIONS				
REV	DESCRIPTION	DATE	DWN	APVD
A	CUSTOMER DRAWING DRAWING RELEASE	10/13/2023	JH	CM

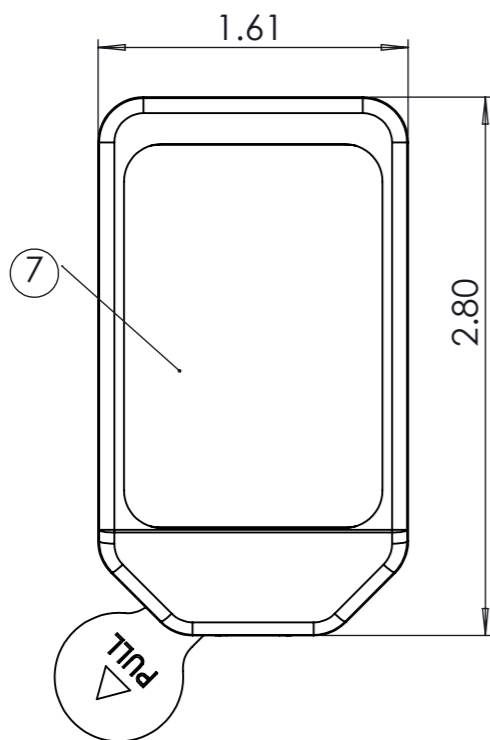
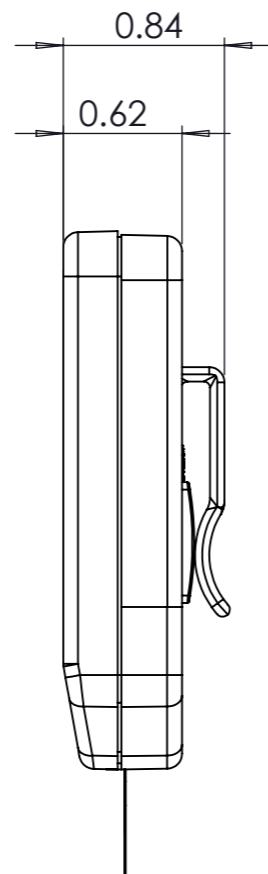
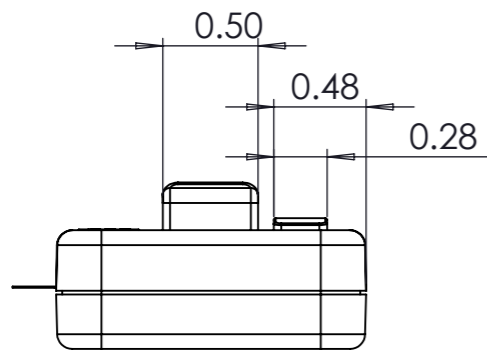

- MANUFACTURE TO BE COMPLIANT WITH EU RoHS DIRECTIVE, USE MATERIALS THAT DO NOT CONTAIN REACH SUBSTANCES OF VERY HIGH CONCERN 1000ppm, AND USE DRC CONFLICT-FREE SOURCED MATERIALS.
- ELECTRICAL SPECIFICATIONS** ARE SHOWN FOR REFERENCE ONLY. FOR OPERATING, PAIRING AND USAGE INSTRUCTIONS PLEASE SEE TE DATA SHEET AT LATEST REVISION
 - FREQUENCY: SEE TABLE
 - ELECTRONIC ASSEMBLY IAW IPC-A-610
 - FREQUENCY DESIGNATION REPRESENTED BY "****".
- ENVIRONMENT:**
 - USAGE TEMPERATURE: -40 TO 85°C
- USAGE APPLICATION NOTES:**
 - TORQUE SCREW TO 4.0 IN-LB [0.45 N-m]. AVOID OVERTIGHTENING OF SCREW AND CAUSING DEFORMATION AT THE SIDE OF THE ENCLOSURE.
 - REMOVE BATTERY TAB BEFORE USE
 - REPLACE BATTERY WITH CR2032 COIN CELL WHEN APPLICABLE. SEE DATA SHEET FOR METHOD
 - AVOID LEAVING UNIT IN PLACES OF HIGH SOLAR LOADING TO PREVENT DAMAGE.
 - AVOID PLACES OF HIGH CHEMICAL CONTENT SUCH AS CHLORINE OR FUEL/HYDRAULIC VAPOR.
 - UNIT SHOULD NOT EXPERIENCE SIGNIFICANT SHOCK FROM DROPPING TO HARD SURFACES. USE BUMPER AND LANYARD KIT [OTX-ACC-KIT-HH-XX] IF THE APPLICATION REQUIRES THIS ACCESSORY.
 - THIS IS A GENERALLY MADE TO ORDER OEM PRODUCT. SEE YOUR SALES REPRESENTATIVE FOR DETAILS SUCH AS AVAILABLE COLORS AND BUTTON LAYOUTS FOR YOUR APPLICATION.
- PACKAGING NOTES:**
 - WRAP UNITS IN BUBBLE SLEEVE TO PROTECT FINISH.
 - PACK FLAT 10/ LOT BAG
 - PLACE IN CONTAINER OF 150 UNITS

TABULATION MATRIX

TCPN	DESCRIPTION
CMD-HHCP-315-MD	REMOTE DS 315MHZ OOK AM 8BTN HHCP TX FCC
CMD-HHCP-315-MD	REMOTE DS 418MHZ OOK AM 8BTN HHCP TX FCC
CMD-HHCP-315-MD	REMOTE DS 433MHZ OOK AM 8BTN HHCP TX FCC
CMD-HHCP-315-MD	REMOTE DS 315MHZ OOK AM 8BTN HHLR TX FCC
CMD-HHCP-315-MD	REMOTE DS 418MHZ OOK AM 8BTN HHLR TX FCC
CMD-HHCP-315-MD	REMOTE DS 433MHZ OOK AM 8BTN HHLR TX FCC

THIS DRAWING IS A CONTROLLED DOCUMENT.

DIMENSIONS: mm	TOLERANCES UNLESS OTHERWISE SPECIFIED: 0 PLC ± 0.5 1 PLC ± 0.25 2 PLC ± 0.13 3 PLC ± 4 PLC ± ANGLES ± 30'
MATERIAL VAR ABS	FINISH

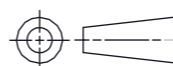

DWN	10/13/23
JHAGER	
CHK	10/13/23
CLEWIS	
APVD	10/13/23
CMURPHY	
PRODUCT SPEC	
APPLICATION SPEC	
WEIGHT	g
CUSTOMER DRAWING	



NAME HANDHELD REMOTE DS TRANSMITTER [FFF]MHZ 8BTN HHCP TX FCC CERT			
SIZE	CAGE CODE	DRAWING NO	RESTRICTED TO
A3	00779	Ⓢ=CMD-HHCP-FFF-MD	-
SCALE 1:1		SHEET 1 OF 2	REV A

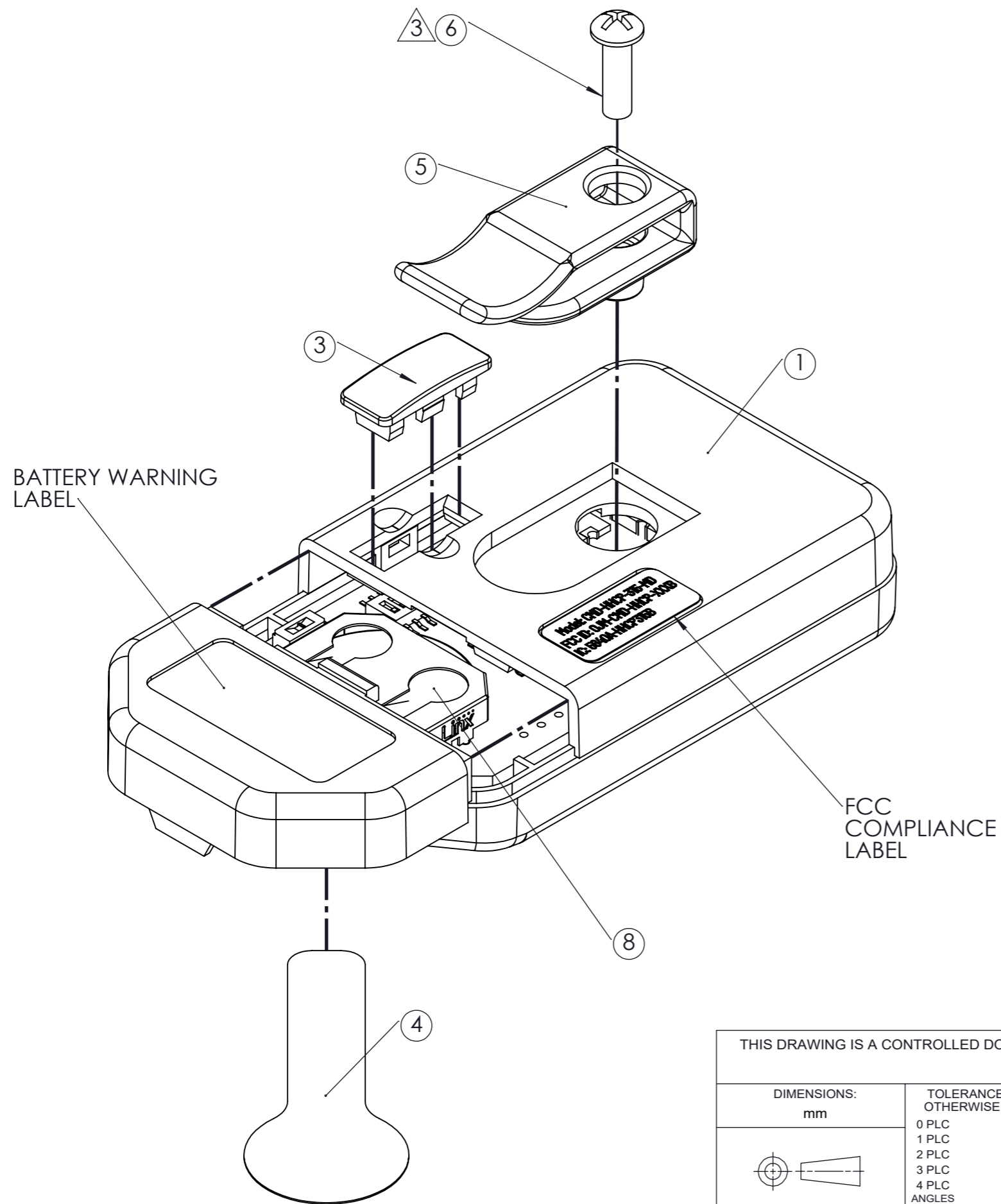

LIST OF ITEMS AND MATERIALS	
ITEM	DESCRIPTION
1	CMD HANDHELD BODY
2	CMD HANDHELD UNIT BATTERY COVER
3	CMD HANDHELD UNIT PROGRAMMING COVER
4	BATTERY PROTECTION TAB (DISPOSABLE)
5	CLIP BELT SCR MOUNT ABS PLAS
6	SCREW PPH M3X10 STEEL ZINC
7	SWITCH MEMBRANE CUSTOM MP467 BACK
8	BATT LITHIUM 1.2V COIN 2032

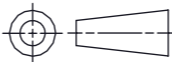
THIS DRAWING IS A CONTROLLED DOCUMENT.		TE TE Connectivity	
DIMENSIONS: mm 		NAME HANDHELD REMOTE DS TRANSMITTER [FFF]MHZ 8BTN HHCP TX FCC CERT	
TOLERANCES UNLESS OTHERWISE SPECIFIED: 0 PLC ± 0.5 1 PLC ± 0.25 2 PLC ± 0.13 3 PLC ± 4 PLC ± ANGLES ± 30°		PRODUCT SPEC - APPLICATION SPEC - WEIGHT g	RESTRICTED TO - SIZE A3 CAGE CODE 00779 DRAWING NO ©-CMD-HHCP-FFF-MD
MATERIAL		FINISH	
CUSTOMER DRAWING		SCALE 2:1	SHEET 2 OF 2 REV A