

Connector: RP-SMA Plug (Female Socket)			
Termination: Cable End Crimp			
Part Number		CONREVSMA012	CONREVSMA012-G
Connector Part	Material	Finish	Finish
Bodies	Body: Brass	Nickel	Gold
	Washer: Phosphor Bronze	Nickel	Gold
	Cover: Brass	Nickel	Gold
	Crimp Ring: Brass	Nickel	Gold
Center Contact	Socket: Be Cu	Gold	Gold
Insulator	PTFE	-	-
Gasket	Silicone Rubber	-	-
Heat Shrink	Polyolefin	-	-

REVISIONS			
REV	DESCRIPTION	DATE	APPV
A	INITIAL RELEASE OF LINX INTERNAL DRAWING	01/MAR/19	CLL

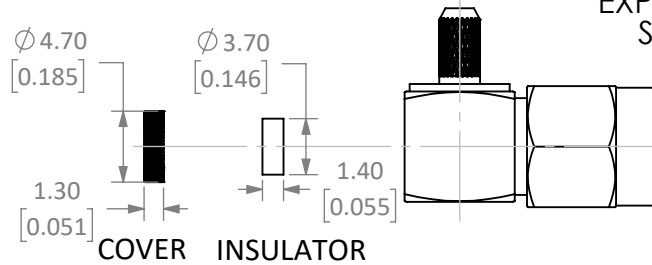

EXPLODED VIEW  
SCALE 2 : 1

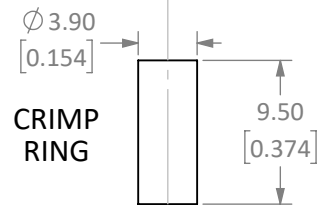
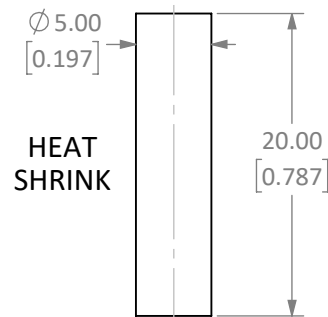
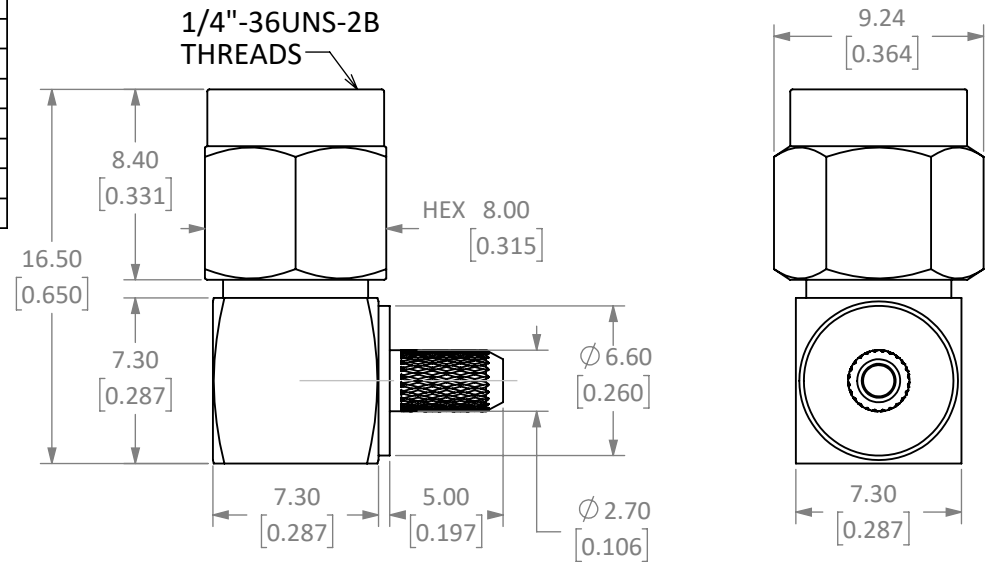

NOTES: (UNLESS OTHERWISE SPECIFIED)

1. ALL DIMENSIONS ARE IN mm [INCHES].
2. DIMENSIONS APPLY AFTER FINISHING.
3. MANUFACTURE TO BE COMPLIANT WITH EU RoHS DIRECTIVE, USE MATERIALS THAT DO NOT CONTAIN REACH SUBSTANCES OF VERY HIGH CONCERN >1000ppm, AND USE DRC CONFLICT-FREE SOURCED MATERIALS.
4. SAFETY BREAK ALL SHARP CORNERS AND EDGES 0.5 MAXIMUM.
5. SEE TABLE I FOR ELECTRICAL SPECIFICATIONS. (SHEET 2)
6. SEE TABLE II FOR ENVIRONMENTAL SPECIFICATIONS. (SHEET 2)
7. SEE TABLE III FOR MECHANICAL SPECIFICATIONS. (SHEET 2)
8. SEE PARTSLIST. "\*" INDICATES FINISH TYPE.

**WARNING:** THIS DRAWING CONTAINS PROPRIETARY INFORMATION THAT IS THE SOLE PROPERTY OF LINX TECHNOLOGIES, AND SHALL BE TREATED AS SUCH. NO DISCLOSURE OR REPRODUCTION OF THIS DOCUMENT IS PERMITTED, IN WHOLE OR IN PART, WITHOUT THE EXPRESS WRITTEN PERMISSION OF LINX TECHNOLOGIES OR ITS DESIGNATED AGENTS.



159 ORT LANE  
MERLIN, OR 97532

TITLE:  
**RP-SMA MALE RIGHT-ANGLE  
CRIMP FOR RG-174 CABLE**

MATERIAL:	INTERPRET DIMENSIONS AND TOLERANCES PER ASME Y14.5. X ±.1                      ANGLES: ±1° .XX ±.01                   SURFACE: √ .XXX ±.005	PROJECTION: 
FINISH:	DRAWN: M. SCHULTE    DT: 21/JAN/19	ENGR:

SIZE	DWG. NO.	REV
<b>A</b>	<b>C-CONREVSMA012</b>	<b>A</b>
SCALE: 3:1		SHEET 1 OF 2

DO NOT SCALE DRAWING

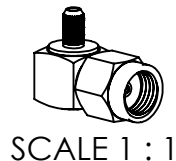

5 TABLE I

Electrical Data	Detail
Impedance	50 $\Omega$
Frequency Range	0 to 18 GHz
Insulation Resistance	5 000 M $\Omega$ min.
Voltage Rating	1 000 V RMS
Contact Resistance	Center: $\leq$ 3.0 m $\Omega$ Outer: $\leq$ 2.5 m $\Omega$
VSWR: f (GHz)	RG-174, or Equivalent 1.15 +0.03f
Working Voltage	RG-174, or Equivalent $\rightarrow$ 335 V RMS max.
Dielectric withstanding Voltage	RG-174, or Equivalent $\rightarrow$ 750 V RMS max.

6 TABLE II

Environmental Data	Detail
Corrosion (Salt spray)	ASTM B-117
Thermal Shock	MIL-STD-202 Method 107 test condition B
Vibration	MIL-STD-202 Method 204 test condition D
Mechanical Shock	MIL-STD-202 Method 213 test condition I
Temperature Range	-55 $^{\circ}$ C to +155 $^{\circ}$ C
Environmental Compliance	RoHS

7 TABLE III

Mechanical Data	Detail
Mounting Type	Free Hanging (In-Line), Right Angle
Fastening Type	1/4"-36 Threaded Coupling
Recommended Torque	0.57 N·m (5.0 in·lbs)
Coupling Nut Retention	60 lbs. min.
Connector Durability	500 cycles min.
Weight	5.8 g (0.2 oz)

## ASSEMBLY INSTRUCTIONS

- Strip the cable to the recommended dimensions.
- Slip heat shrink and crimp ring onto stripped cable.
- Slide the cable into the body until the center-conductor is centered in the fork.
- Push the braided shield over the barrel.
- Solder the center-conductor into the center of the fork.
- Slide the crimp ring over the shield and crimp using a 0.128" hex crimp tool (or one labeled for use with RG-174 cable).
- Trim off any excess shield wire sticking out from the ring.
- Slip the heat shrink over the crimp ring until it is against the body and shrink.
- Insert insulator into the body.
- Push the cover into the opening.

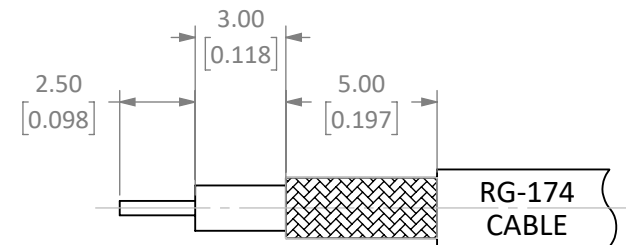

RECOMMENDED CABLE STRIPPING DIMENSIONS  
CAN ALSO BE USED WITH:  
RG-188A & RG-316

SIZE	DWG. NO.	REV
<b>A</b>	<b>C-CONREVSMA012</b>	<b>A</b>
SCALE: 4:1	DO NOT SCALE DRAWING	SHEET 2 OF 2