

Connector: SMA Jack (Female Socket)		
Body Style	PCB Edge Mount	
Connector Part	Material	Finish
Body	Brass	Gold
Center Contact	Socket: BeCu	Gold
Insulator	PTFE	-

REVISIONS			
REV	DESCRIPTION	DATE	APPV
A	INITIAL RELEASE OF SOLID MODEL	CLL	6-FEB-20

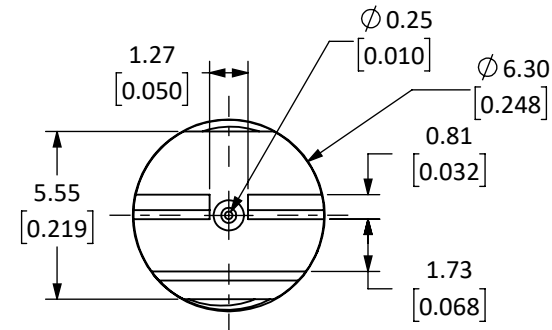
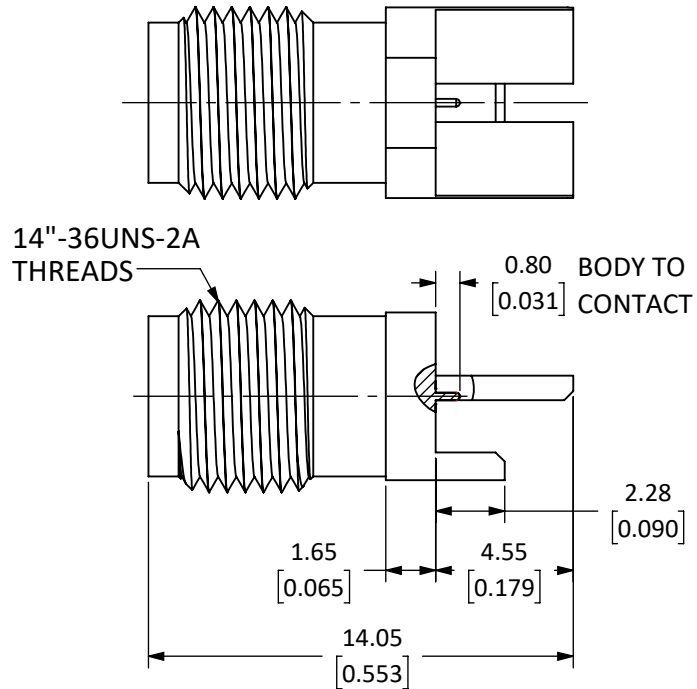

NOTES: (UNLESS OTHERWISE SPECIFIED)

1. ALL DIMENSIONS ARE IN MILLIMETERS [INCHES].
2. DIMENSIONS APPLY AFTER FINISHING.
3. MANUFACTURE TO BE COMPLIANT WITH EU RoHS DIRECTIVE, USE MATERIALS THAT DO NOT CONTAIN REACH SUBSTANCES OF VERY HIGH CONCERN >1000ppm, AND USE DRC CONFLICT-FREE SOURCED MATERIALS.
4. SAFETY BREAK ALL SHARP CORNERS AND EDGES 0.5 MAXIMUM.
5. SEE TABLE I FOR ELECTRICAL SPECIFICATIONS. (SHEET 2)
6. SEE TABLE II FOR ENVIRONMENTAL SPECIFICATIONS. (SHEET 2)
7. SEE TABLE III FOR MECHANICAL SPECIFICATIONS. (SHEET 2)

WARNING: THIS DRAWING CONTAINS PROPRIETARY INFORMATION THAT IS THE SOLE PROPERTY OF LINX TECHNOLOGIES, AND SHALL BE TREATED AS SUCH. NO DISCLOSURE OR REPRODUCTION OF THIS DOCUMENT IS PERMITTED, IN WHOLE OR IN PART, WITHOUT THE EXPRESS WRITTEN PERMISSION OF LINX TECHNOLOGIES OR ITS DESIGNATED AGENTS.



159 ORT LANE
MERLIN, OR 97532

TITLE:
**SMA FEMALE EDGE MOUNT
FOR 0.062" BOARD, GOLD**

MATERIAL:	INTERPRET DIMENSIONS AND TOLERANCES PER ASME Y14.5. X ±.1 .XX ±.01 .XXX ±.005	PROJECTION:
FINISH:	ANGLES: ±1° SURFACE: √	
	DRAWN: M. SCHULTE DT: 22-JAN-20	
	ENGR: D. VARATHARAJAN DT: 6-FEB-20	

SIZE	DWG. NO.	REV
A	C-CON SMA021.062-G	A
SCALE: 4:1	DO NOT SCALE DRAWING	SHEET 1 OF 2



SCALE 1 : 1

5 TABLE I

Electrical Data	Detail
Impedance	50 Ω
Frequency Range	0 to 26.5 GHz
Insulation Resistance	≥ 5000 M Ω
Voltage Rating	1000 V RMS
Contact Resistance	Center ≤ 2.0 m Ω Outer: ≤ 2.0 m Ω
VSWR	≤ 1.5 @ 18 GHz to 26.5 GHz

6 TABLE II

Environmental Data	Detail
Corrosion (Salt Spray)	MIL-STD-202 METHOD 101 TEST CONDITION B
Thermal Shock	MIL-STD-202 METHOD 107 TEST CONDITION B
Vibration	MIL-STD-202 METHOD 204 TEST CONDITION D
Mechanical Shock	MIL-STD-202 METHOD 213 TEST CONDITION I
Temperature Range	-65 °C to +165 °C
Environmental Compliance	ROHS

7 TABLE III

Mechanical Data	Detail
Mounting Type	PCB Edge Mount
Fastening Type	1/4"-36UNS-2A Threaded Coupling
Recommended Torque	0.57 N.m (5 in.lbs)
Coupling Nut Retention	60 lbs min.
Connector Durability	500 cycles min.
Weight	1.5 g (0.05 oz)

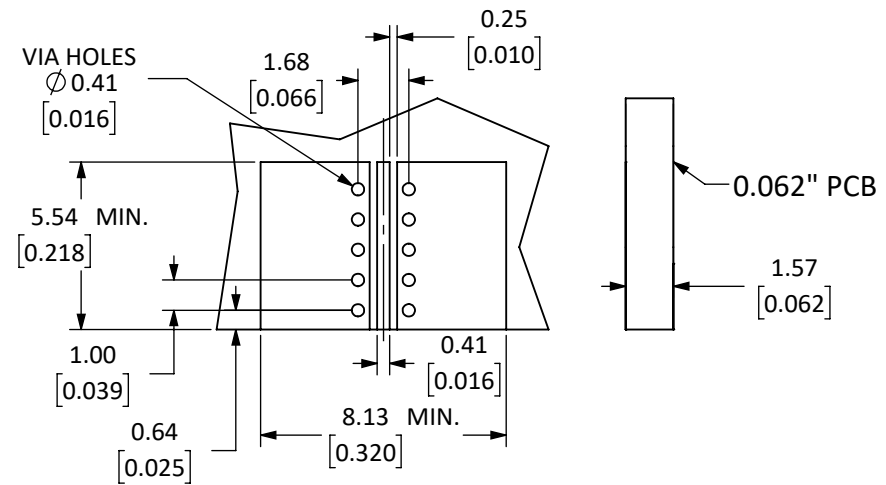

RECOMMENDED FOOTPRINT

SIZE	DWG. NO.	REV
A	CONSMA021.062-G	A
SCALE: 4:1	DO NOT SCALE DRAWING	SHEET 2 OF 2